

# Design of Sinusoidal Pulse Width Modulation 3 Phase Bridge Inverter

Vinay Kumar Pal<sup>1</sup>, Swati Singh<sup>2</sup>

<sup>1</sup>PG Student [Power System], Dept. of EEE, Maharishi University of Information Technology, Lucknow, U.P., India

<sup>2</sup>Assistant Professor, Dept. of EEE, Maharishi University of Information Technology, Lucknow, U.P., India

\*\*\*

**Abstract** - In this article, Pulse Width Modulation (PWM) controlled 3-phase inverter for Renewable Energy (RES) Applications and environmental constraints are presented. The three-phase inverter with reduced components is realized in the solar PV applications. As the use of renewable energy sources are increased and will going to be increased to a large extend in future. Specially, solar energy will going to play a huge role as a major energy source. The output of the inverter is direct current, so an inverter becomes a critical component for the flow of electricity from solar modules to storage battery, loads and grids. A three phase voltage source inverter Sinusoidal Pulse Width Modulation based inverter is going to be utilized. High frequency carrier wave is compared with sinusoidal reference wave of desired frequency. The width of each pulse is varied in proportion to the amplitude of a sine wave called SPWM. The advantage of SPWM technique is that it reduces the harmonic contents of the output voltage compared to single pulse width modulation and multi-pulse modulation. The advantage of inverter with two stage three phase bipolar SPWM is good performance and efficiency as it doubles the switching frequency of inverter voltage and so the output filter becomes smaller, cheaper and easier to implement.

**Key Words:** SPWM (Sinusoidal Pulse Width Modulation), PWM (Pulse Width Modulation), Induction motor, 3 phase bridge inverter.

## 1. INTRODUCTION

Energy is the considered to be the pivotal input for DC-AC inverters have been widely used in industrial applications such as uninterruptible power supplies, static frequency changes and AC motor drives. Recently, the inverters are also playing important roles in renewable energy applications as they are used to link a photovoltaic or wind system to a power grid. Like DC-DC converters, the DC-AC inverters usually operate in a pulse width modulated (PWM) way and switch between a few different circuit topologies, which means that the inverter is a nonlinear, specifically piecewise smooth system. In addition, the control strategies used in the inverters are also similar to those in DC-DC converters. For instance, current-mode control and voltage-mode control are usually employed in practical applications. In the last decade, studies of complex behavior in switching power converters have gained increasingly more attention from both the academic community and industry[1-2]

This application leads to the power conversion i.e. AC/DC and DC/AC. AC/DC converting device, also know a rectifier

is designed using diode or thyristor to provide uncontrolled and controlled dc power, also said as unidirectional and bidirectional devices. Other than Adjustable Speed Drive (ASD); Switch Mode Power Supply (SMPS), DC power supply (for measurement and testing), Uninterrupted Power Supply (UPS), Battery charging set, Grid interface of Solar PV module, and etc. employs AC/DC conversion. Controlled device is advantageous as the input harmonics is less and power factor is higher as compared to uncontrolled, because of which used of heavy and costly line filters can be eliminated. These controlled device uses power switches like MOSFET, IGBT, GTO, etc. One of the best methods for speed control application is V/F control of induction motor, Pulse Width Modulation (PWM) or Sinusoidal Pulse Width Modulation (SPWM) can be use to provide the triggering pulse for both the converters with feedback control (in some applications)[3]. For more reliable operation and results filters can be used at the line side [8]. PWM gate pulse is designed with suitable modulation index; it will also give the required Total Harmonic Distortion (THD). By varying the modulation index (m) current and voltage harmonics can be varied [8]. rectifier. required pulse of triggering signal generator [1,4]. Output voltage from an inverter can also be adjusted by exercising a control within the inverter itself. The most efficient method of doing this is by pulse-width modulation control used within an inverter.

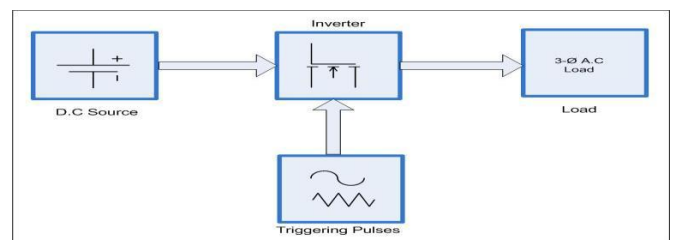

Figure.1: Basic Block diagram of SPWM Inverter

In this method, a fixed dc input voltage is given to the inverter and a controlled ac output voltage is obtained by adjusting the on and off periods of the inverter components. This is the most popular method of controlling the output voltage and this method is termed as Pulse-Width Modulation (PWM) Control[11].

The advantages possessed by PWM techniques are as under:

- The output voltage control with this method can be obtained without any additional components.
- With the method, lower order harmonics can be eliminated or minimized along with its output voltage control. As higher order harmonics can be

filtered easily, the filtering requirements are minimized.

The main disadvantage of this method is that SCRs are expensive as they must possess low turn-on and turn-off times.

## 2. INDUCTION MOTOR

In induction motor both stator and rotor are made laminated silicon steel lamination used to reduce Eddy current loss and silicon used to reduce hysteresis loss, and consists of an insulated winding to carry current and magnetic flux. The stator provides path for the magnetic field and the housing for the stator windings. When single phase alternating supply is fed to the stator of induction motor, the ac current circulates in the stator winding. This flowing current produces a flux having alternating nature known as stator flux. The generated flux links with the rotor windings and hence rotor conductor cuts the stator flux as a result emf induces in the rotor winding. Current will flow in the rotor as the rotor windings are short circuited, this current is said as rotor current[5].

### A. Working Principal:

When the rated AC supply is applied to the stator windings, it generates a magnetic flux of constant magnitude, rotating at synchronous speed. The flux passes through the air gap, sweeps past the rotor surface and through the stationary rotor conductors. An electromotive force (EMF) is induced in the rotor conductors due to the relative speed differences between the rotating flux and stationary conductors. The frequency of the induced EMF is the same as the supply frequency. Its magnitude is proportional to the relative velocity between the flux and the conductors. Since the rotor bars are shorted at the ends, the EMF induced produces a current in the rotor conductors. The direction of the rotor current opposes the relative velocity between rotating flux produced by stator and stationary rotor conductors (per Lenz's law). To reduce the relative speed, the rotor starts rotating in the same direction as that of flux and tries to catch up with the rotating flux. But in practice, the rotor never succeeds in 'catching up' to the stator field. So, the rotor runs slower than the speed of the stator field[6]. This difference in speed is called slip speed. This slip speed depends upon the mechanical load on the motor shaft.

### B. Torque- speed characteristics of induction motors:

V / f control speed control technique (frequency control). This is one of the most widely used methods especially for the Adjustable Speed Drive (ASD) or Variable Frequency Drive (VFD) which is basically used for controlling the speed of the motor[7].

The torque developed by the motor is directly proportional to the magnetic field produced by the stator. So, the voltage applied to the stator is directly proportional to the product of stator flux and angular velocity. This makes the flux produced by the stator proportional to the ratio of applied voltage and frequency of supply. By varying the frequency, the speed of the motor can be varied. Therefore, by varying the voltage and frequency by the same ratio, flux and hence, the torque can be kept constant throughout the speed range.

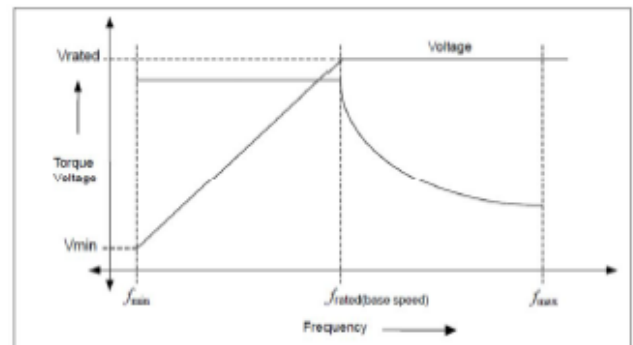

Figure.2 : Speed torque characteristics of Induction Motor

### C. Total Harmonic Distortion (THD) effect in Induction Motor:

The advancement in the controlled operation and other applications of controlled output voltages leads to the increasing use of power electronics. This power switches are one of the major reasons for the production of harmonics with different orders in the system. It is nothing but the sine component of the periodic waveform having a frequency in the integral multiples of the fundamental frequency. First order harmonic is addressed as Fundamental frequency (f), second order harmonic can be described as 2f followed by third harmonic as 3f and likewise. Even harmonics are eliminated naturally as the overall distortion gets cancelled, positive cycle = negative cycle[9].

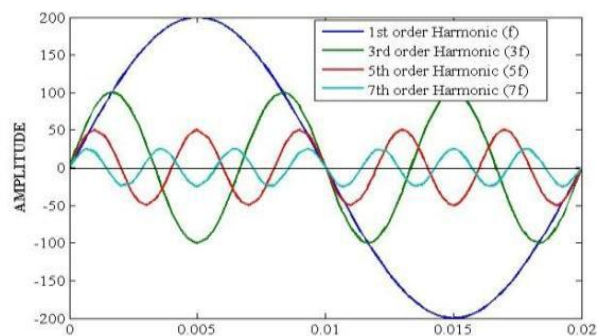

Figure.3 : THD Effect on Induction Motor

### 3. PULSE WIDTH MODULATION TECHNIQUE

Inverter outputs can be controlled by exercising pulse width modulation techniques or PWM within the inverter. PWM method is implemented in inverter by adjustment of ON and OFF periods of inverter IGBTs. Among all other PWM techniques SPWM technique is preferable as by using this method direct control of inverter output voltage and frequency can be done according to the sine functions used. In this method the pulse amplitude remains constant while the duty cycles are different for each period of time. By modulating the width of pulses, inverter output voltage can control and reduction of THD can be done [12].

The pulse signal generation in SPWM technique is being done by comparing the sinusoidal reference signal with triangular carrier signal of cut off frequency  $f_c$ . The switching devices will be ON whenever the reference sinusoidal signals become greater than the carrier triangular wave [13]. The line side Fundamental component frequencies and magnitudes can be varied by varying modulation signal frequency and magnitude [14]. Here in three phase voltage source inverter three sine waves are needed as a reference signals and they are phase shifted by  $120^\circ$  with the desired output voltage frequency is taken. The signals are compared to a carrier signal with very high frequency. The waveforms of sine and triangular wave comparison and also pulse generation is shown in Fig. 4.

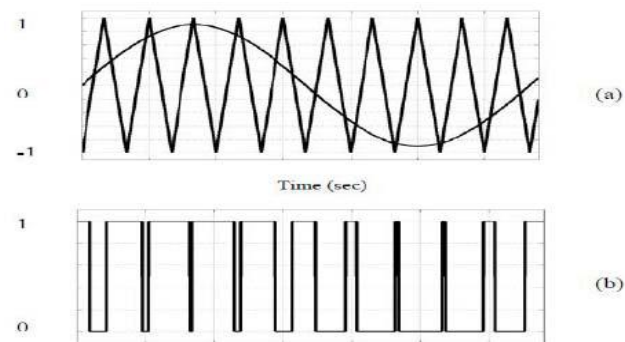

Figure 4: SPWM method: (a) Sinusoidal and triangular comparison; (b) Generation of switching pulses.

### 4. SIMULATION MODEL & RESULT

The output voltage and current waveforms of three phase voltage source inverter with harmonic analysis using FFT toolbox with Gate pulse triggering and SPWM triggering are shown below using MATLAB Simulink. The data considered in this model is as follows:

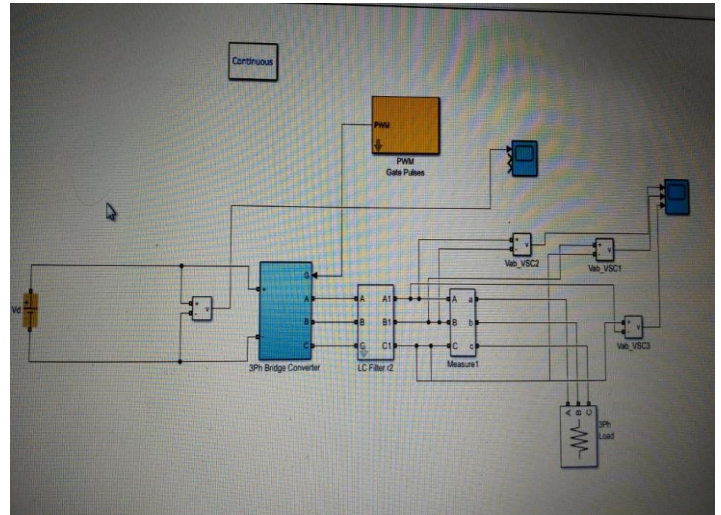

Figure.5 : Simulink Model of PWM based Bridge Inverter

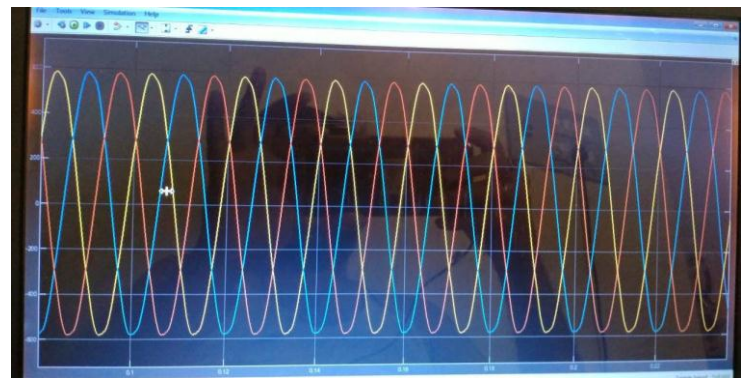

Figure 6: Simulink Result of PWM based Bridge Inverter

### 5. CONCLUSIONS

From all the simulation results it is seen that the designed Op-Amp/Analog circuit controlled PWM inverter works accurately. It fulfills all the requirements for a voltage source inverter. The THD is less than 5% after filtering. The inverter outputs can be varied by varying the resistance of potentiometer. The inverter responds better for standalone inductive loads.

If the power is not enough to supply to the Power system then it will supply the power to the local standalone loads. If the carrier frequency is increased much enough then the filtering system will be much better and the loss will be less. But better response can be achieved by using the feedback system, means the closed loop control system. The future work can be done on the feedback loop system.

## 6. References:

1. Rajesh Kumar Ahuja, Amit Kumar "Analysis, Design and Control of Sinusoidal PWM Three Phase Voltage Source Inverter Feeding Balanced Loads at Different Carrier Frequencies Using MATLAB" International Journal of Advanced Research in Electrical, Electronics and Instrumentation Engineering Vol. 3, Issue 5, May 2014
2. Nazmul Islam Raju, Md. Shahinur Islam, Ahmed Ahsan Uddin "Sinusoidal PWM Signal Generation Technique for Three Phase Voltage Source Inverter with Analog Circuit & Simulation of PWM Inverter for Standalone Load & Micro-grid System" international journal of renewable energy research vol.3, no.3
3. A.Ali Qazalbash, Awais Amin, Abdul Manan and Mahveen Khalid "Design and Implementation of Microcontroller based PWM technique for Sine wave Inverter" POWERENG 2009 Lisbon, Portugal, March 18-20, 2009.
4. Pankaj H Zope, Pravin G.Bhangale , S. R.Suralkar "Design and Implementation of Carrier Based Sinusoidal PWM (Bipolar) Inverter" International Journal of Science and Research (IJSR), India Online ISSN: 2319-7064. Volume 1 Issue 3, December 2012
5. Pranay S. Shete , Rohit G. Kanojiya, Nirajkumar S. Maurya "Performance of Sinusoidal Pulse Width Modulation based Three Phase Inverter" International Conference on Emerging Frontiers in Technology for Rural Area (EFITRA) 2012 Proceedings published in International Journal of Computer Applications (IJCA)
6. C. S. Sharma & Tali Nagwani "Simulation and Analysis of PWM Inverter Fed Induction Motor Drive" International Journal of Science, Engineering and Technology Research (IJSETR) Volume 2, Issue 2, February 2013 ISSN: 2278 – 7798.
7. Amit Kumar Sharma, Tushar Deep Saxena, Shirazul Islam & Arun kumar Yadav "Performance Analysis of Three Phase PWM Voltage Source Inverter Fed Three Phase Induction Motor Drive" International Journal of Advanced Electrical and Electronics Engineering (IJAEED) ISSN (Print) : 2278-8948, Volume-2, Issue-2, 2013.
8. Umashankar S, Ratika Singh Rawat, Priyanka Rana, Nakul Thombre "Hardware Implementation of Three Level NPC Inverter Using dSPACE DS1104 Controller Interface" dSPACE User Conference 2014 – India | Sept 12th' 2014
9. "IEEE Recommended Practices and Requirements for Harmonic Control in Electrical Power Systems," IEEE Std 519-1992.
10. Thakur, Neha, and Rakesh Singh Lodhi. "THD Analysis of Output Voltage for VSI fed Induction Motor Drives." International Journal of Engineering and Management Research (IJEMR) 4, no. 4 (2014): 130-133.
11. Esa, Mohd, and Mohd Abdul Muqem Nawaz. "THD analysis of SPWM & THPWM Controlled Three phase Voltage Source Inverter." (2017). International Research Journal of Engineering and Technology (IRJET), Volume: 04 Issue: 10, pp. 391-398.
12. H. Hussin, A. Saparon, M. Muhamad, and M.D. Risin, "Sinusoidal pulse width modulation (SPWM) design and implementation by focusing on reducing harmonic content", Mathematical Modeling and Computer Simulation (AMS), 2010 Fourth Asia International Conference, 2010. pp. 620-623.
13. S. Mustafa, Alkhazragi and K.AL-Shamaa Nabil, "Cascaded H-Bridge Multilevel Inverter Using SPWM and MSPWM Strategies" Int. Journal of Engineering Research and Application, Vol. 7, Issue 6, (Part -2) 2017, pp.14-20.
14. Umashankar, S., VK Arun Shankar, Geet Jain, and Mohan L. Kolhe. "Comparative evaluation of pulse width modulation techniques on effective DC link voltage utilization of grid connected inverter." In Electrical, Electronics, and Optimization Techniques (ICEEOT), International Conference on, IEEE, 2016. pp. 2376-2383.