

# Improving the Security using Substandard Cameras for Real Time Detection of Abnormal Events

**Vaibhav Rai<sup>1</sup>**

Computer Science and Engineering  
Don Bosco Institute of Technology  
Bangalore, India

**Rakshitha R<sup>2</sup>**

Computer Science and Engineering  
Don Bosco Institute of Technology  
Bangalore, India

**Varshini A S<sup>3</sup>**

Computer Science and Engineering  
Don Bosco Institute of Technology  
Bangalore, India

**Jobby Jolly<sup>4</sup>**

Computer Science and Engineering  
Don Bosco Institute of Technology  
Bangalore, India

**Shilpa S.G<sup>5</sup>**

Assistant Professor  
Computer Science and Engineering  
Don Bosco Institute of Technology  
Bangalore, India

\*\*\*

**Abstract** - in real world application tracking objects from low resolution live video is a challenging task. The existing methods either use a high resolution camera or convert the low resolution video to high resolution which increases costs. In this paper we propose a new methods which are able to detect abnormal events without such type of conversion and are best suited for enhancement of security of ATM's. Our proposed system uses a low resolution camera for streaming the video. From the video we take frames and use rolling average background subtraction technique to detect foreground object from dynamic background in a scene. We also use haar cascade classifier to detect faces and YOLO v3 model to detect objects from the live video. These methods can be best applied to increase the security of the ATM's. It can easily detect more than two people inside the ATM or if someone is carrying a weapon or if the face is covered by mask or helmet and it send the message to the concerned authority. It is fast enough because it processes low resolution frames and could be helpful in other surveillance systems.

**Key Words:** Camera; Substandard; Abnormal Event; Security, Low Resolution; ATM

## 1. INTRODUCTION

In recent decades, substantial efforts in the field of moving target object detection and tracking have remained complete to make subsequent applications robust, reliable and efficient: authentication system, video surveillance, robotics, internet-of-things, etc. However there are many tasks which yield difficulty in the enhancement of these mentioned applications. These challenges may contain dynamic background, change in illumination, occlusion, facade, shadow, etc. These hurdles become further awkward when we execute target object tracking in low resolution video. However there are assured advantages of using low resolution video such as it requires low cost, low transmission time, processing time and storage.

In present-day applications, tracking object in low resolution video is a stimulating task due to loss of distinctive aspect in the visual appearance of moving target object. Using suitable Face recognition algorithms like the haar classifier, the face is detected of the customer who enters the ATM by using the frames captured by the cameras. If customer's face is covered by helmet or mask then it will be detected by the classifier and will treat it as abnormal event. If more than one customer enters inside ATM, it can be prevented by detecting it as an abnormal behavior as we have examples of robbery inside ATMs.

The motion sensors and vibration sensors senses the human motion and detect the abnormal behavior of a person. Proposed system can use a substandard USB camera however we have used the web camera for the prototype. Web camera will stream the live video and frames will be captured for image processing. We are using Open CV, open source image processing algorithms for our system. We are using the concept of Naïve Bayesian classifiers and hence we train our classifier for the abnormal event detection. Once abnormal event is detected, the surveillance system can be automated that it automatically locks the door of that ATM and sends the alarming message to security person present in the observation room so that action can be taken. We are using Arduino UNO micro-controllers for these operations. Alert SMS is triggered on the abnormal event detection to the security office and sent to the security guards as well. The Message triggering is done using GSM module or the twilio API. The Required Coding is done using Python. The abnormal event in the ATM can be prevented by using this system. The algorithm we have used is very simple and can be enhanced by adding more features as the need arises by training our own classifiers.

## 2. PROPOSED SYSTEM

As we know that, object tracking and event detection becomes very difficult in low resolution camera due to loss of visual discriminative information. Usage of super

resolution techniques and classifiers are not very efficient as they require either high computational costs or high processing capability or both. We present a new solution to the above problem without the usage of super resolution techniques or classifiers. We are able to implement object tracking and event detection with the help of electronic Devices and also with image processing techniques.

Through statistical concepts and logical perception of human actions, the proposed system is able to achieve object tracking and event detection. It detects an event as abnormal by taking different conditions into consideration and application of image processing techniques using Open CV. It decides events such as Face Masking, Camera Masking, Overcrowding, excessive number of motions in short period of time and a possible attempt for ATM dismantling as abnormal and simultaneously sends the alert messages to the concerned authorities in investigation (surveillance) system for improving the ATMs security and prevention of thefts using simple camera of low resolution.

### 3. IMPLEMENTATION

#### A) Software Implementation

##### 1) Python with OpenCV

For the project, we chose to use Python Open CV as the programming language. It is a high-level language that specializes in data analysis and computing mathematical problems. Python Open CV's official website can be found at [www.mathworks.com](http://www.mathworks.com).

The program environment has an interactive command window that allows users to test and experiment with the code line by line. Users can also save their codes into an M-file and run the program. The Python Open CV Help Navigator is also very useful. It properly categorizes and provides detailed explanations and sample usages of all functions. Just like C++ and Java, the language syntax provides loops and condition statements for programming purposes.

The language python was chosen over C++ and Java because there are a lot of built-in functions that are specific for image processing. As well, the compiler can compute large mathematical equations faster than other languages. These advantages suit the project perfectly due to the large matrix computations required during the extraction process.

##### 2) Twilio REST API

Twilio's APIs (Application Programming Interfaces) power its platform for communications. Behind these APIs is a software layer connecting and optimizing communications networks around the world to allow your users to call and message anyone, globally.

#### B) Hardware Implementation

##### 1) A Substandard Web Camera

A webcam is a small digital video camera directly or indirectly connected to a computer or a computer network. Webcams come with software that needs to be installed on the computer to help users record video on or stream it from the Web. Webcams are capable of taking pictures as well as high definition videos, although the video quality can be lower when compared with other camera models.

##### 2) Arduino UNO

The Arduino Uno R3 is a microcontroller board based on a removable, dual-inline-package (DIP) ATmega328 AVR microcontroller. It has 20 digital input/output pins (of



which 6 can be used as PWM outputs and 6 can be used as analog inputs). Programs can be loaded on to it from the easy-to-use Arduino computer program. The Arduino has an extensive support community, which makes it a very easy way to get started working with embedded electronics. The R3 is the third, and latest, revision of the Arduino Uno.

##### 3) Motion Sensor and Vibration Sensor

The main purpose of motion detection is to sense an intruder and send an alert to your control panel, which alerts your monitoring centre. Sensors work when you are not home, or when you tell the system you are not there. Some security systems can be programmed to record events via a security camera when motion is detected. Motion Sensor stand guard, ready to react to various situations, such as movement in your living room, windows or doors being opened or closed, or a broken window.

##### 4) LCD 16X2 Display

An LCD (Liquid Crystal Display) screen is an electronic display module and has a wide range of applications. A 16x2 LCD display is very basic module and is very commonly used in various devices and circuits. A 16x2 LCD means it can display 16 characters per line and there are 2 such lines. In this LCD each character is displayed in 5x7 pixel matrix. The 16 x 2 intelligent alphanumeric dot matrix display is capable of displaying 224 different characters and symbols. This LCD has two registers, namely, Command and Data. Command register stores various commands given to the display. Data register stores data to be displayed. The process of

controlling the display involves putting the data that form the image of what you want to display into the data registers, then putting instructions in the instruction register.

### 5) DC Motor interfaced with L293D

We use motor for automatically closing of ATM door when an abnormal or unusual event occurs. DC motor if connected directly with Arduino may burn or damage Arduino. The reason for this is that the Arduino can only handle supplying a small amount of power and most motors would draw more power than the Arduino can supply.

When we use the H-Bridge, we supply the power for the motor(s) from an external power source so we do not put any strain on the Arduino's power supply.

### 4) SYSTEM DESIGN AND FLOW CHARTS

#### A) Block diagram of the current System.

The Proposed system uses an USB camera or web camera of the laptop or PC and inbuilt speakers. These are interfaced with ARDUINO processor via UART serially. Web camera will stream the live video into the PC where all processing of the captured image frames happens to detect any unusual event inside ATM using the developed code. After detecting unusual event the surveillance system has been automated in such a way that it automatically locks the door of that particular ATM .Sends the alarming message including mail to security personnel present in the common observation room so that necessary action could be taken.

A panic switch can be used to alert the local people. PIR sensor has been used to auto switch on lighting's inside the ATM by detecting the human motion. The Message triggering is done using twilio API. As the device is connected with internet, auto mail triggering is done through a configured mail address to the security agency control room.

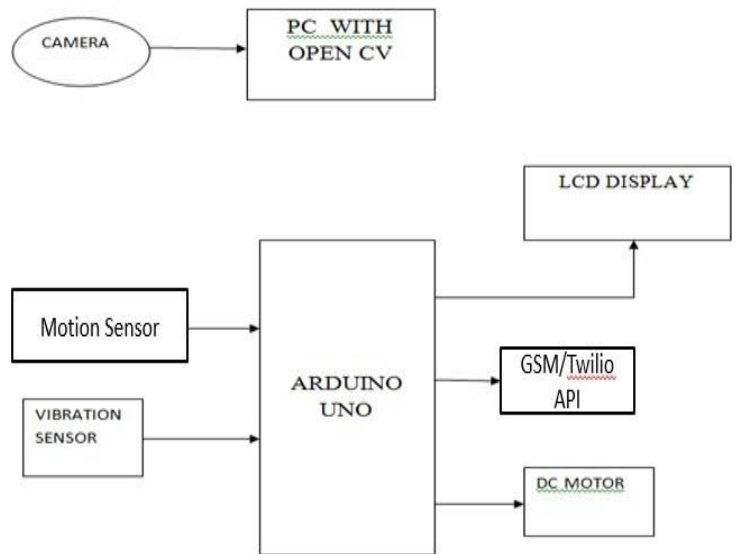

#### B) Flow chart

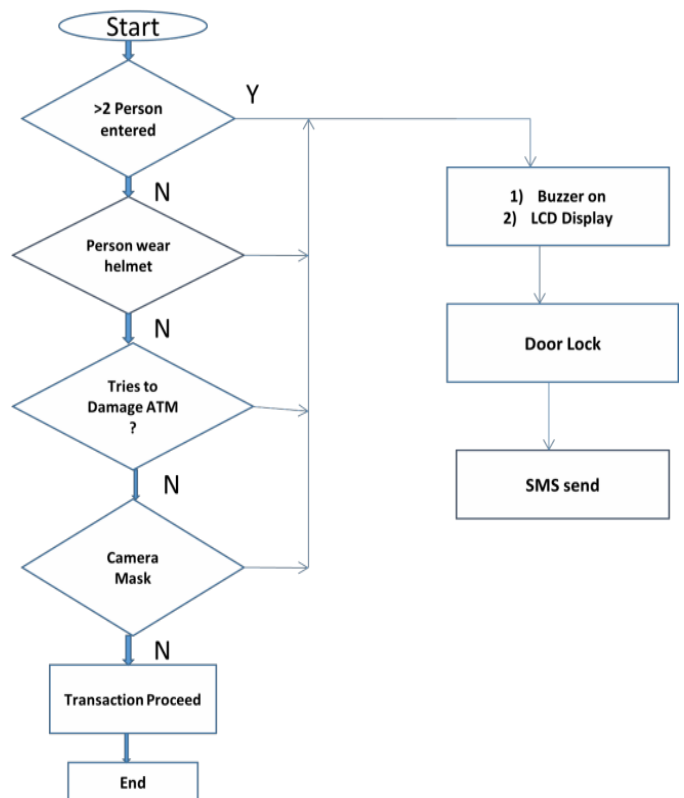

### 5) EXPERIMENTAL ANALYSIS AND RESULTS

The results for multiple face detection, Weapon detection and helmet detection are shown in below figures respectively.

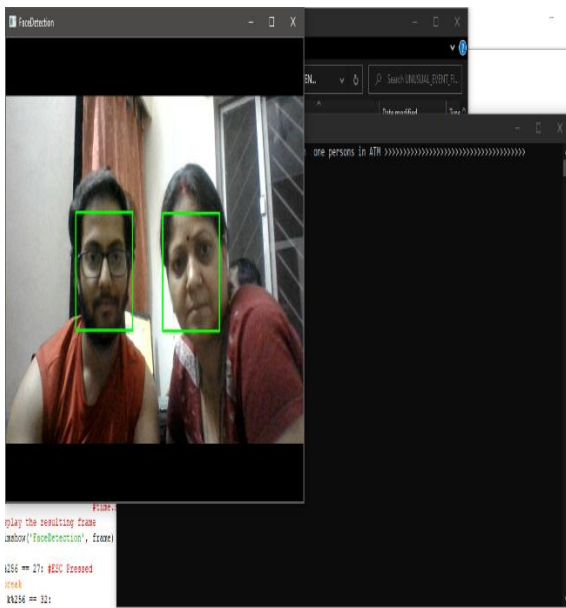

Fig 1. Multiple faces being detected.

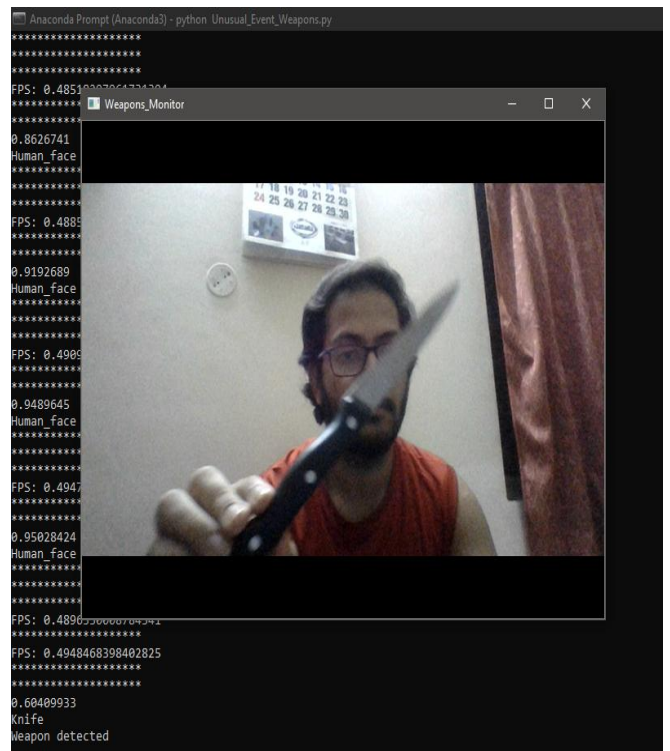

Fig 3. Weapon detection from live video.

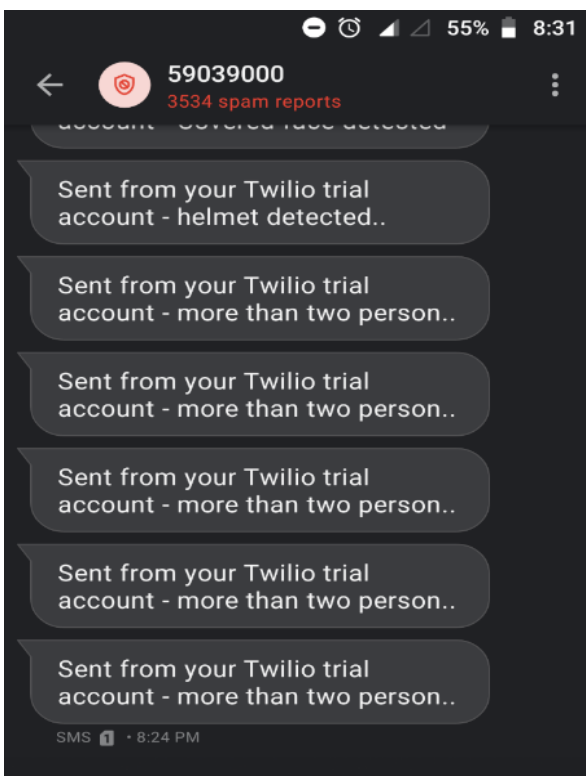

Fig 2. Message sent to phone.

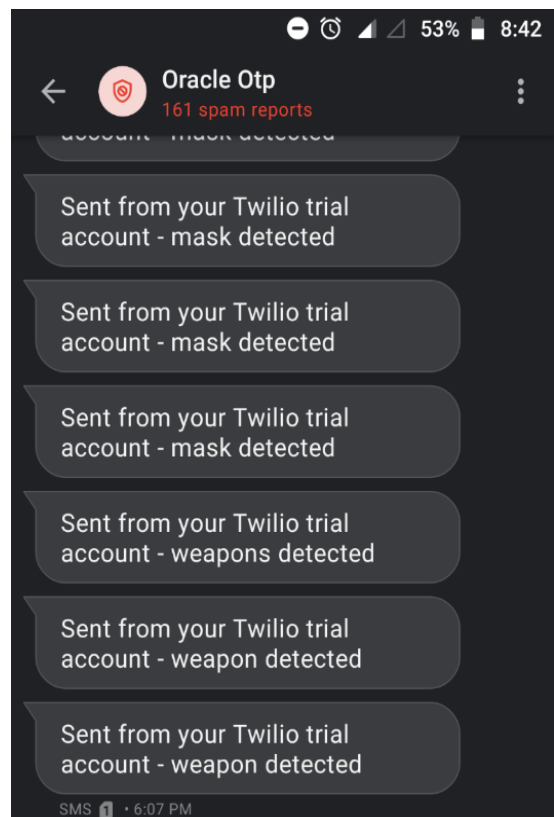

Fig 4. Message sent to phone.

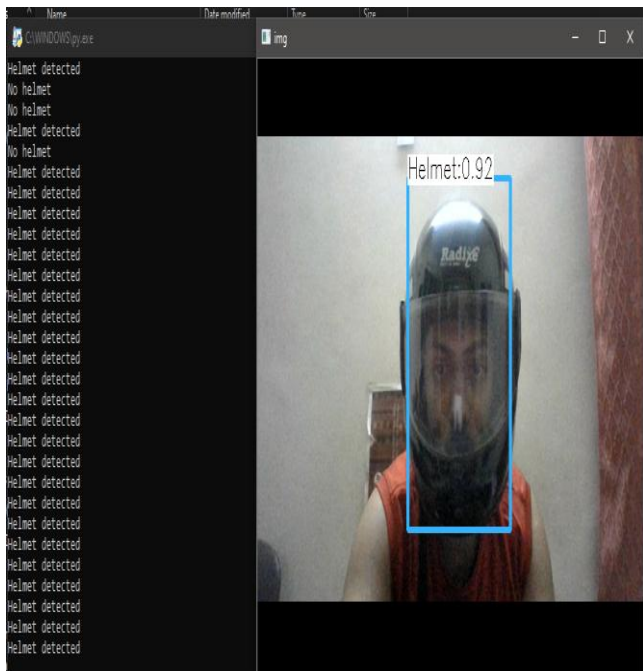

Fig 5. Helmet Detection.



Fig 7. Hardware Implementation.

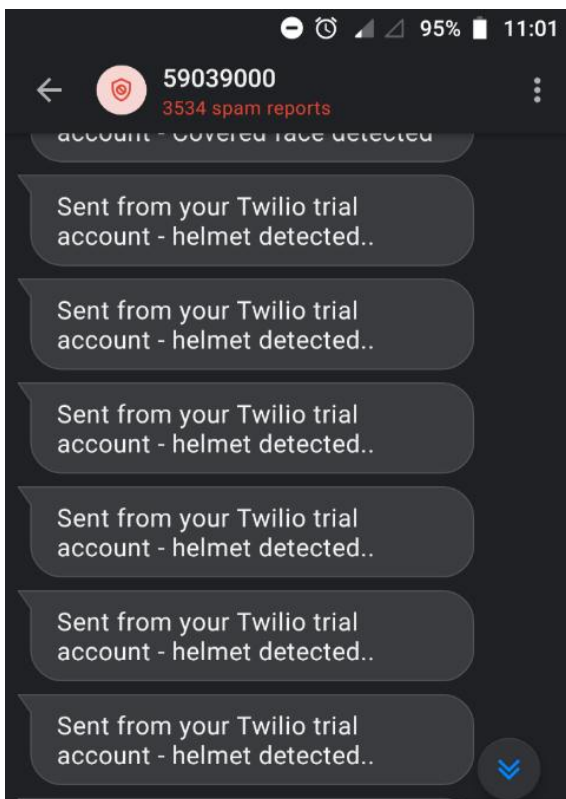

Fig 6. Message Sent to the phone.

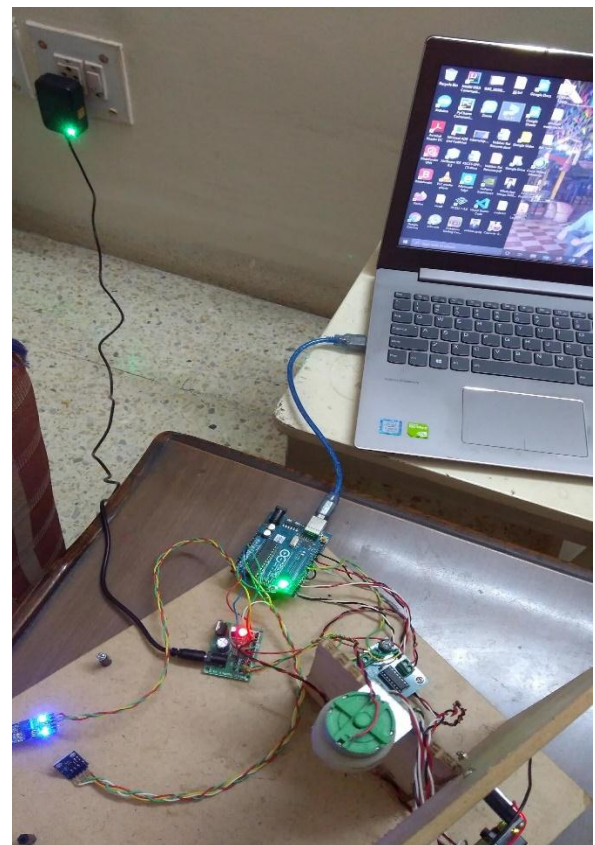

Fig 8. Hardware Implementation.

## CONCLUSION

The Proposed system has been designed based on the principle of multi-layer security with background subtraction techniques. An ATM unusual event detection system should follow a complete framework, starting from the very first trace of movement to decision making, of the detection process. There is no need of using high computational scheme that enhance low resolution videos by super resolution techniques. Work is extended to detect more uncommon events in ATM such as attempt to steal ATM, harming the ATM screen and theft within the ATM. Several detection methods were found that needs to be chosen carefully depending on reliable and unique features of face postures, human motion and object characteristics. It was found that recognition rate and accuracy rates are the performance measures mostly used by the investigations. We can prevent the intruder or a terrorist entry inside the ATM, suppose if they manage to gain entry then immediate action can be taken. In this project, we have tried to put forth a solution to an apprehensive issue of fraudulent transactions through ATM by biometrics that can be made possible only when the account holder is physically present. The proposed work may help future researchers and engineers to develop dynamic and multipurpose algorithms for ATM. It also contributes to the development of a completely automatic ATM video surveillance system that can control the alarming rate of ATM crime.

## ACKNOWLEDGEMENT

We extend our sincere thanks to our project guide Mrs. Shilpa S.G. and our Computer Science and Engineering dept. for their encouragement.

We also would like to thank our institution Don Bosco Institute of Technology.

## REFERENCES

- [1] Bhavani.H.M, Enhanced ATM Security System With Automatic Abnormal Event Detection And Alert System to Reduce Banking Cost. International Journal for Research in Applied Science and Engineering Technology
- [2] Sweeti, Sharon, Banu, Thasleema, Rajapriya, Sharmila, Prabavathy, UNUSUAL EVENT DETECTION AND ENHANCING THE SECURITY SYSTEM. International Journal of Advanced Research Trends in Engineering and Technology (IJARTET) 2019 p 349-352
- [3] Sudhir Goswami, Jyoti Goswami and Nagresh Kumar "Unusual event detection in low resolution video for enhancing ATM security", IEEE 2nd International Conference on Signal Processing and Integrated Networks (SPIN), 2015
- [4] Sikandar, Tasriva, Ghazali, Kamarul, Rabbi, Mohammad. ATM crime detection using image processing integrated video surveillance: a systematic review 2018 Multimedia Systems

- [5] Saleem Ulla Shariff, Maheboob Hussain and Mohammed Farhaan Shariff, "Smart Unusual Event Detection Using Low Resolution Camera for Enhanced Security", International Conference on Innovations in Information Embedded and Communication Systems (ICIIECS), 2018.

- [6] Elise Epailard and Nizar Bouguila, "Variational Bayesian Learning of Generalized Dirichlet-Based Hidden Markov Models Applied to Unusual Events Detection". IEEE Transactions on Neural Networks and Learning Systems (2019).

- [7] Zahraa Kain, Abir Youness, Ismail El Sayad, Samih Abdul-Nabi, Hussesin Kassem, "Detecting Abnormal events in university Areas". International Conference on Computer and Applications (ICCA) 2018.