

Design and Implementation of Four Quadrant DC drive using Class E Chopper

Rajesh Shrivastava^{#1}, Priyank Shrivastava^{*2}, Dr. Manish Sawale^{#3}, Prof. Manju Gupta^{*4}

¹ M.Tech-Scholar, Department of Electrical Engineering, OIST, Bhopal, M.P.

² Asst.Professor, Department of Electrical Engineering, OIST, Bhopal, M.P

³H.O.D. Department of Electrical Engineering, OIST, Bhopal, M.P

⁴Professor Department of Electrical Engineering, OIST, Bhopal, M.P

Abstract:- The speed control of separately excited DC motor can be done by using choppers from 0 to rated speed. The chopper responds by providing variable voltage to the armature for receiving desired speed in accordance with the signal received from controller via firing circuit. There are two controlling loops one for controlling current and one for controlling speed. In this way modeling of separately excited DC motor is done. The model is simulated using matlab after obtaining the complete model of the system. Simulation is done for analyzing various speeds and load torque conditions. The above simulated model can be implemented as applicable to be used in HEV'S in open loop working in the entire four quadrants as per voltage v/s current plot. The IGBT'S are triggered by using pulse width modulation technique. Recent HEV employs a complex control system that involves vehicle to work on electric motor till the speed switch over the control of vehicle of the IC engine. The speed limit depends upon the efficiency of the IC engines in its initial gears. Therefore in the above context, the four quadrant operation is designed to operate at speeds from 0 to 700rpm.

Keywords -HEV'S(Hybrid Electrical Vehicles), I.C. Engines, Chopper, IGBT, DC Motor.

I. Introduction

The application of DC-DC convertors are widely found in switched mode power supplies. Input of the converter varies widely especially when the source is renewable source. So the input to these converters is unregulated but the output from this is expected to be harmonic and ripple free. Voltage regulation in the DC-DC converters is achieved by continuous adjustment of the amount of energy absorbed from source that is injected in the load which in turn can be achieved by controlling the time intervals of energy absorption and injection in the circuits. These two basic process of absorption and injection constitutes a switching cycle presented as duty cycle of operation D. There are two modes of operation current continuous and current discontinuous mode.

Various techniques were applied aiming at regulating chopper's duty cycle 'd' for reducing voltage ripple's and to maintain voltage at minimum switching losses. PWM converters are required to operate at high frequency due to demand high power density with reduced switching losses by using soft switching techniques. In order to achieve this aim zero-voltage switching method is employed in the main circuit with an auxiliary circuit that is activated just before the main circuit is to be turned on and id deactivated after sometime. Auxiliary circuit consist of IGBT((active switch) and passive elements (inductances and capacitances) that have lower ratings than the main circuit as auxiliary circuit is only activated for the fraction of switching cycle. PWM with such circuits are referred as zero-voltage transitions. The auxiliary circuits can be a non-resonant circuit with hard turn off or resonant circuit with soft turnoff.

II. Chopper

A chopper is a static power electronic device that converts fixed DC input voltage to variable dc output voltage. The average value of output voltage V_o can be controlled through duty cycle by opening and closing of semiconductor switch periodically.

Control strategies:

1. Time ratio control : - In this control scheme ,duty ratio T_{on}/T is varied .This can be achieved by two different ways i.e; constant frequency system and variable frequency system
2. Current limit control: - In this control strategy, the on and off of chopper circuit is decided by the previous set value of I_L . The two set values are I_{Lmax} and I_{Lmin} when the load reaches the upper limit the chopper is off and vice versa. Switching frequency can be set by maximum and minimum level of current. PWM Technique is commonly used for power control in chopper circuits.

Chopper types:

Class A Chopper – The first quadrant chopper operates in the first quadrant of V-I Plane with power flowing from source to load as both V & I are positive. Therefore the DC motor runs in forward direction and the speed of the motor can be varied by varying the duty cycle of the chopper

Class B Chopper – The second quadrant chopper operates in the second quadrant of the V-I Plane power flows from load to source as I is negative in this quadrant. Chopper operation is only possible if load is with an active element.

Class C Chopper – The Two quadrant chopper operated in the first and the second quadrant of the V-I Plane .Hence the power is bidirectional .With DC motor as a load ,the chopper operates the motor in the forward operating mode in first quadrant and forward regenerative mode in the second quadrant.

Class D Chopper – The two quadrant chopper operates in the first and fourth quadrant of V-I Plane. Again the power is bidirectional with the DC motor(load) operated in forward motoring and reverse generated mode

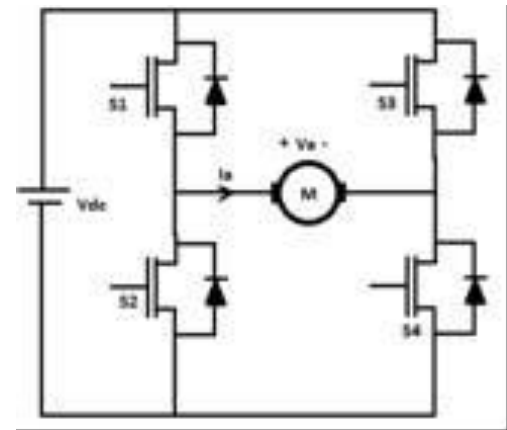

Fig1 Class E Chopper diagram

From the above figure the load to operate in first quadrant (forward motoring), switches T1 & T4 are operated. Here T1 is switched while T4 is kept open .Therefore both the V & I across and through the load are positive rotating the motor in forward direction. Now the speed of the motor can be varied by varying the duty cycle of the switch T1. As the duty cycle varies the voltage across the armature of the motor varies proportionally thereby varying the motor speed as the N is proportional to armature voltage.

Now for applying brakes electrically, the chopper is to be operated in second quadrant .This can be done by operating switch T2 .When T2 is ON ,the inertial energy of the motor that is stored in the inductance of armature circuit ,voltage across inductor increases .Once the switch is turned off the voltage across inductor adds with the back EMF of the motor feeding inertial energy back to the source through freewheeling diodes D1 & D4 .For energy to be feedback to the source the combined voltage of the inductor and back EMF must be more than Vs. If the inertial energy of the motor is fed back to source it is called 'regenerative braking' & if dissipated in resistor it is called electric braking .motor is in forward regenerative mode.

III. Class E Chopper

Operation of the four quadrant chopper is explained with a DC motor as shown in diagram below.

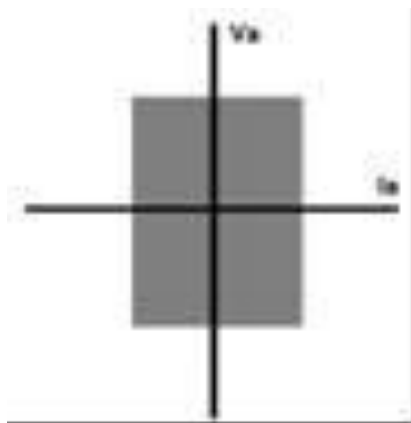

G Quadrant of operation

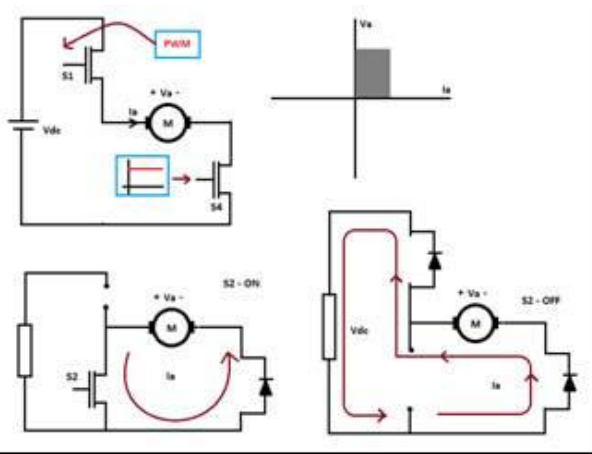

Fig-2 Schematic showing type of triggering in quadrant 1 (top left), first quadrant representation (top right), Braking mode with s2 closed (bottom left), Braking mode with s2 opened (bottom right)

To operate the chopper in third quadrant, switch T3 & T2 are operated. Here, switch T3 is switched and T2 is kept on. Now the V & I across and through the load are negative driving the motor in reverse direction. Also the speed of the motor can be varied by varying the duty cycle of switch T3. Motor is in reverse motoring mode.

Now to operate the motor in the fourth quadrant only switch T4 is operated. With switch T4 turned on, voltage across armature inductance increases. When T4 is tuned off, voltage across inductor adds to the back EMF. If combined voltage is more than the source voltage, inertial energy is supplied back to the supply.

IV. Modelling

The simulated model of the drive is simulated in open loop with pre-specified time interval for each quadrant of about 1sec. The first quadrant (forward motoring) and third quadrant (reverse motoring) modes are simulated for 1 sec each and second and fourth quadrant area also for 1 sec each in a loop. Figure 3 represents the outline of the simulated model. The energy generated in second and fourth quadrants are dissipated in the form of heat across a resistor.

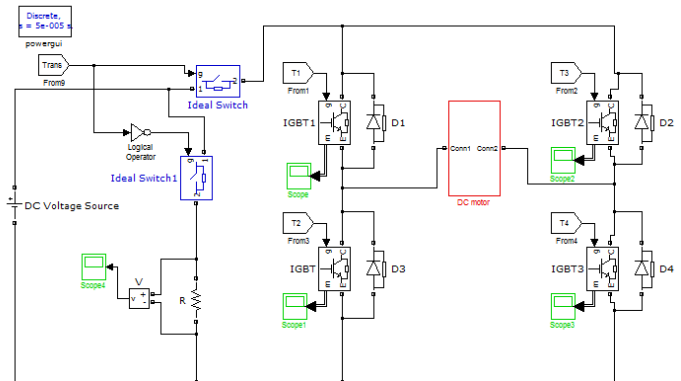

Fig-3 Simulink model of proposed model

In this proposed simulation method, a separately excited DC motor is made to run in all four quadrants. For this purpose for IGBT switches are used for H-Bridge configuration. The motor circuit acts like a buck converter & like a boost converter in braking mode of operation. A unique logical sequence is implemented in this simulation to present the four quadrant operation in a single timeline.

In motoring mode of operation when T1 is off the motor's inductive energy should be allowed through a freewheeling diode. In case of reversing mode of operation. The same freewheeling diode diverts the motor and creates a dead short circuit across the supply. Hence the above said logic is utilized to reverse the connection of the freewheeling diode

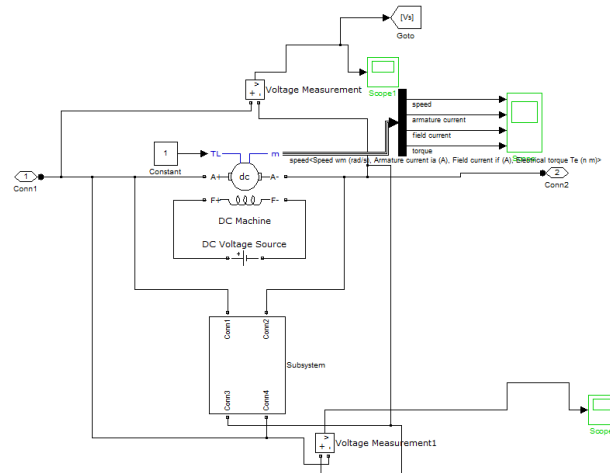

fig-4 sub circuit of reversible fwd (left)

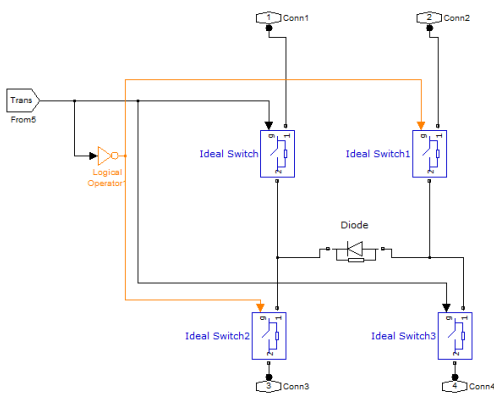

Fig-5 sub circuit of reversible FWD (right)

The simulated time is allotted for 4 sec in which 2 sec is for forward and 2 sec for reverse motoring operation. A pulse generator is configured with period 4 sec and pulse width 50%. The mark time of the pulse operates the motor in forward mode and space time operates the motor in the reverse mode.

Pulse generator used for transition triggering is configured with a period of 2 sec and pulse width of 50%. The mark time is for motoring and space time is for braking. As the period of this pulse is half the time line pulse. The transition pulse creates two modes of operation i.e; motoring and braking. For triggering the IGBT pulse generators are configured with 1khz frequency and the duty ratio can be adjustable

In forward motoring, T4 continuously conducts and T1 is operated via PWM1. After 1 sec, the transition pulse goes off (braking mode) that makes changeover switch to connect to zero(off). Simultaneously changeover switch (x2) shifts to PWM2. During this braking mode switch 2 is ON, moment of inertia makes the motor to operate as a generator and charge the current.

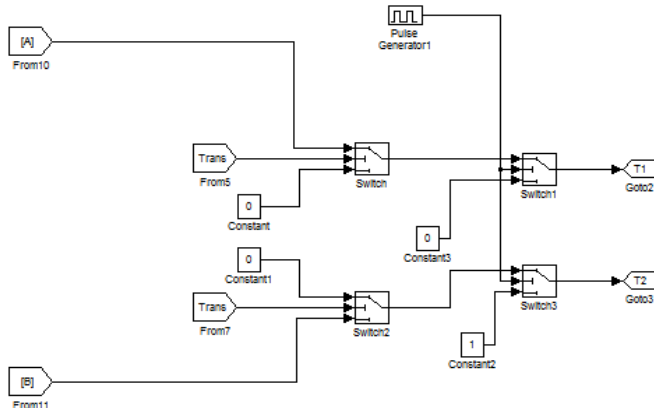

fig-6 forward motoring triggering logic

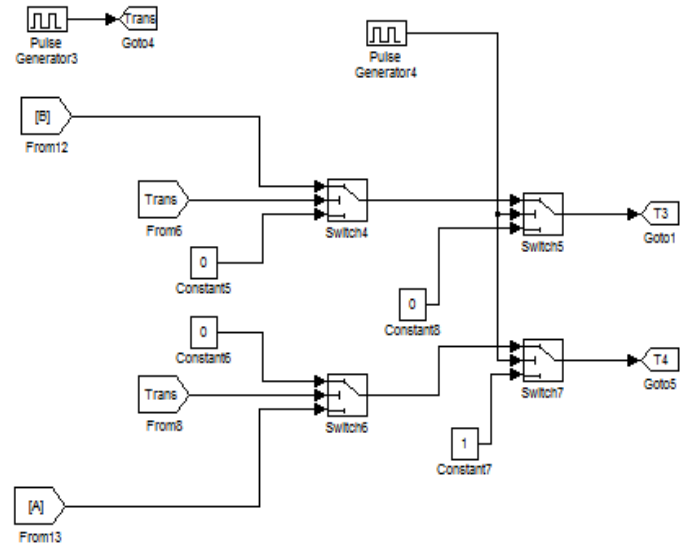

Fig-7 Reverse motoring Triggering logic

V. Simulation

The armature voltage, speed and regeneration voltage for all four quadrants.

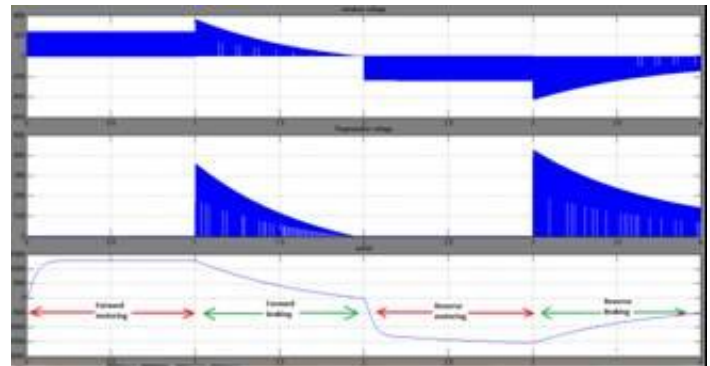

Fig 8 Armature voltage, regeneration voltage, speed

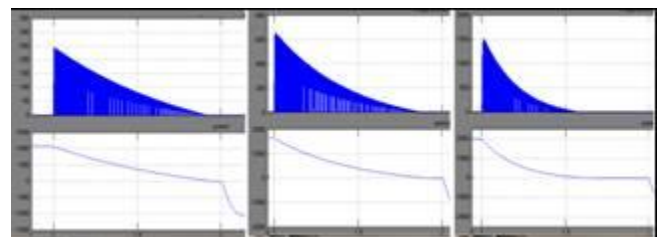

Fig-9 Braking periods comparisons for duty ratio 50%, 75%.90%

Motor is loaded with 1-nm when braking is initiated, speed suddenly drops and the regeneration voltage starts rising. The negative speed indicates the motor is in reverse operation mode.

In Fig 10 comparison between braking periods and duty ratio is shown .At 50% duty cycle braking period is almost one fourth of the time line period .But at 90% duty cycle time dropped to about half as observed in case of 50% duty cycle duty ratio . The more the ON time more the inductance charges it increases the regenerative and braking torque

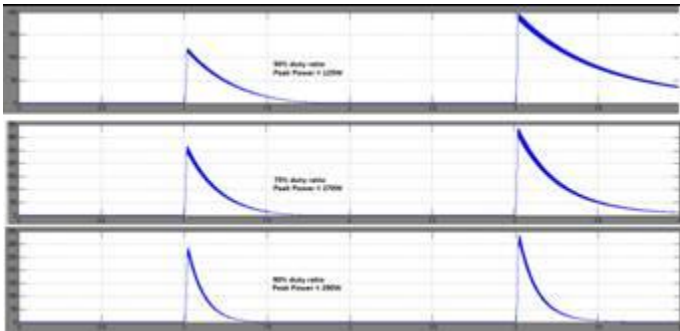

Fig-10 Regenerative power for different ratio

The regenerative power is around 125W for 50% duty ratio and 290W for 90% duty ratio .The braking response of various load torques is shown in fig-11

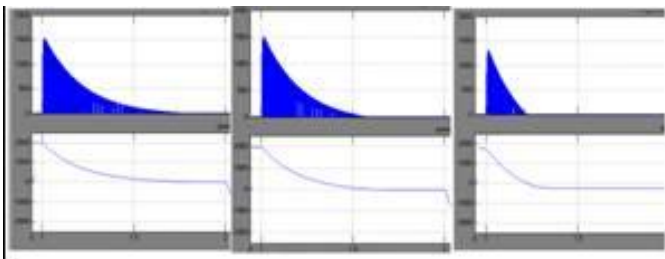

Fig-11 Braking effect at different load torques (1n-m to 10 n-m)

Braking time for zero load torque is equal to the allotted period of quadrant operation of 1 N-M the braking period drops to 50% and for 10 N-M , braking period is about one fourth of the zero torque condition .

VI. Result

The four quadrant operation DC Drive is successfully implemented. In simulation we had seen that more will be the load torque, less will be the application of braking. Combining the above two results the motor can be properly controlled by changing the duty ratio for specified load torque. Also the output voltage in the regenerative mode is boosted more than the supply voltage.

VII. Future scope

By designing snubber circuit more accurately the complete drive can be made more sophisticated & simpler .Magnetic inertia of the motor is not sufficient to overcome the magnetic locking of the motor under regenerative mode, therefore magnetic inertia of the motor is to be increased for better running conditions.

VIII. References

- [1] Bhimbhra, P.S., Power Electronics, New delhi, khanna Publishers, 2006.
- [2] Dubey G.K., Fundamental of Electrical Drives, New delhi, Narosa Publishing House, 2009.
- [3] Rashid, M.H. Power Electronics, Prentice hall of India, New delhi, 1993.
- [4] Design and implementation of four quadrant DC Drive using chopper B. Nikhil Krishna; Budigapaka Nagaraju; P Vinod Kumar 2015 International Conference on EESCO 2015.