

Design and Simulation of Grid Connected Solar PV System by using MPPT Charge Controller

V. Sivakumari¹, M. Santosh kumar²

¹V. Sivakumari, M-Tech Student Scholar, Dept. of Electrical & Electronics Engineering, Vikas College of Engineering and Technology, Nunna, Krishna(Dt), A.P, India.

²Sri. M. Santosh Kumar, Assistant Professor, Dept. of Electrical & Electronics Engineering, Vikas college of Engineering and Technology, Nunna, Krishna(Dt), A.P, India.

Abstract - This Paper aimed at introduced a standard procedure for the design of large-scale institutional grid-connected solar PV systems using the roofs of buildings and car parks. The standard procedure was validated in the design of a grid-connected solar PV system by using transformer coupled dual input converter. Grid-connect PV systems with battery back-up (sometimes referred to as uninterrupted power supply or hybrid solar PV systems) are becoming most popular. With solar customers in many states now receiving a low price for electricity sold back to the grid, battery back-up systems can be a viable alternative as they use the electricity stored during the day to run your house at night. They also have the advantage of being able to supply power during power outages. Grid-connected systems do not need batteries which decrease considerably initial capital costs and energy costs. For a comparable load, grid-tied systems use smaller PV arrays than stand-alone systems. In order to address this issue, this scheme consisting of a novel transformer coupled dual-input converter (TCDIC) followed by a conventional full-bridge inverter is proposed. The proposed TCDIC can realize maximum power point tracking (MPPT) and battery charge control while maintaining the proper voltage level at the load terminal. A suitable control strategy for the proposed TCDIC devised for manipulating the TCDIC to realize the first two aforementioned objectives, while the third objective is achieved by employing a conventional proportional integral (PI) controller to control the output voltage of the full bridge inverter through sinusoidal pulse width modulation (PWM). The simulation results are performed by using Matlab/Simulink software.

1. INTRODUCTION

Nowadays demand for power throughout the world greater and these demands cannot meet by non-renewable energy sources (like thermal and hydro generation) because of limited availability of coal and water. Hence entire world foot forward to the non-conventional energy sources like wind and solar energy they never going to be depleted, and these are the most promising alternatives to replace conventional energy sources [1], [2]. But effective utilization of renewable sources and for getting maximum power output requires fast acting power electronic converters [3]. For three-phase applications, two types of power electronic configurations are commonly used to transfer power from

the renewable energy resource to the grid: 1) single-stage and 2) double-stage conversion. In the double stage conversion for a PV system, the first stage is usually a dc/dc converter and the second stage is a dc/ac inverter. In first stage the DC-DC converter provides maximum power tracking from PV module and also produces appropriate DC voltage for stage-2 inversion. In stage-2 (inversion stage) inverter produces 3- ϕ sinusoidal voltages or currents and it transfers power to load connected or to the grid [4].

In the case of single-stage connection, only one converter is desired to fulfill the double-stage functions, and hence the system will have a lower cost and higher efficiency, however, a more complex control method will be required. For industrial high power applications need a 3- ϕ system, single stage PV energy systems by using a voltage-source converter (VSC) for power conversion [5], [6], [7]. Because of unpredictable and fluctuating nature of solar PV and wind energy systems the output of these systems not constant at terminal ends to overcome such difficulty a battery storage system is employed. This also can boost the tractability of power system control and increase the overall availability of the system [8].

High-gain multi winding transformer-based converters can be used to address this issue. However, such systems require a minimum of eight controlled switches. This is in addition to the four switches that are required to realize the inverter. Furthermore, existing stand-alone schemes employ an additional dedicated dc-dc converter to realize MPP operation. As PV power remains unavailable for more than half of a day, the utilization of this aforementioned dedicated converter becomes very poor [9].

A scheme wherein the use of a dedicated dc-dc converter for MPPT operation is avoided is proposed. This scheme has the PV array and battery connected in series and is designed for application in PV-powered lighting system. However, the scheme presented has the following limitations:

- 1) The presence of resonant elements makes the system sensitive to parameter variation;
- 2) Permissible variation in the duty ratio of the switches is limited within a certain range; and
- 3) Voltage gain is quite limited. A similar approach has also been reported for application in a grid-connected scheme.

However, the aforementioned schemes have to bypass the PV array by a diode and an inductor when PV power goes to zero.

This results in overall gain reduction as the PV and battery are connected in series.

In order to address the disadvantages encountered a transformer-coupled dual-input converter (TCDIC)-based solar PV system scheme is proposed in this paper. The input stage of the proposed TCDIC is realized by connecting the PV array in series with the battery, thereby facilitating the boosting capability of the converter. The output voltage level of the TCDIC is further enhanced by incorporating a high-frequency step-up transformer. The unique feature of TCDIC is that it can be made to perform MPPT operation, battery charge control, and voltage boosting by employing a proper control algorithm [10].

Hence, all of the facilities that are achieved in the existing stand-alone schemes by involving two or more stages of dc-dc converters can be obtained by employing the proposed single stage TCDIC. A standard full-bridge inverter is employed at the output of TCDIC to achieve dc-ac conversion. The basic philosophy of this scheme and its very preliminary study have been presented, and subsequently, further work that has been carried out on this scheme is presented in this paper [11].

A photovoltaic (PV) system is able to supply electric energy to a given load by directly converting solar energy through the photovoltaic effect. The system structure is very tractable. PV modules are the main building blocks; these can be arranged into arrays to increase electric energy production. Normally additional equipment is necessary in order to transform energy into a useful form or store energy for future use. The resulting system will therefore be determined by the energy needs (or loads) in a particular application. PV systems mostly classified in two major groups [12]

1.2 Photovoltaic system

These systems are isolated from the electric distribution grid. Figure.1 describes the most common system configuration. The system described in Figure.1 is actually one of the most complex; and includes all the elements necessary to serve AC appliances in a common household or commercial application. An additional generator (e.g., bio-diesel or wind) could be considered to enhance the reliability but it is not necessary. The number of components in the system will depend on the type of load that is being served. The inverter could be eliminated or replaced by a DC to DC converter if only DC loads are to be fed by the PV modules. It is also possible to directly couple a PV array to a DC load when alternative storage methods are used or when operating schedules are not of importance. A good example may be water pumping applications were a PV module is

directly coupled to a DC pump, water is stored in a tank through the day whenever energy is available.

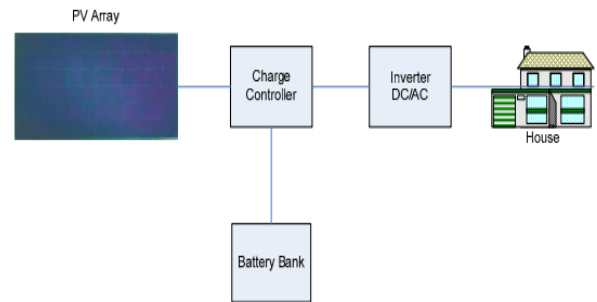

Fig.1. Photovoltaic System.

1.3 Grid-Tied

These systems are directly coupled to the electric distribution network and do not require battery storage. Figure.2 describes the basic system configuration. Electric energy is either sold or bought from the local electric utility depending on the local energy load patterns and the solar resource variation during the day, this operation mode requires an inverter to convert DC currents to AC currents. There are many benefits that could be obtained from using grid-tied PV systems instead of the traditional stand-alone schemes. These benefits are:

- Smaller PV arrays can supply the same load reliably.
- Less balance of system components are needed.
- Comparable emission reduction potential taking advantage of existing infrastructure.
- Eliminates the need for energy storage and the costs associated to substituting and recycling batteries for individual clients. Storage can be included if desired to enhance reliability for the client.
- Takes advantage of the existing electrical infrastructure.
- Efficient use of available energy. Contributes to the required electrical grid generation while the client's demand is below PV output.

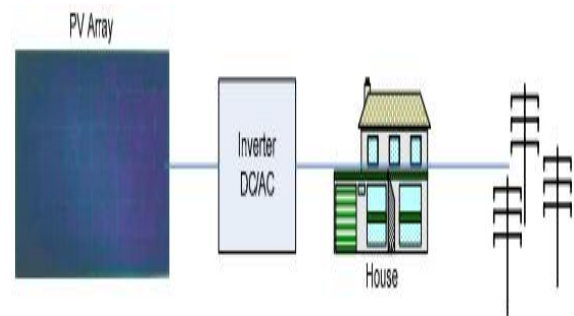

Fig.2. Grid-Tied Photovoltaic System.

Hybrid systems may be possible were battery storage or a generator (or both) can be combined with a grid connection for additional reliability and scheduling flexibility (at

additional cost). [13] Most of the installed residential, commercial and central scale systems use pre-fabricated flat plate solar modules, because they are widely available. Most 5-7 available reports on PV system costs are therefore related to this kind of technology and shall be our focus in this chapter. Other specialized technologies are available (e.g., concentrating PV systems), but not as commercially available as the traditional PV module.

2. OPERATING PRINCIPLE OF TCDIC

The schematic diagram of the TCDIC is depicted in Fig. 3. From this figure, it can be noted that no dedicated converter

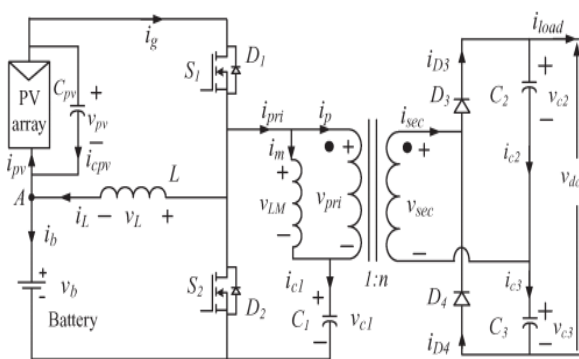

Fig. 3. Schematic circuit diagram of TCDIC.

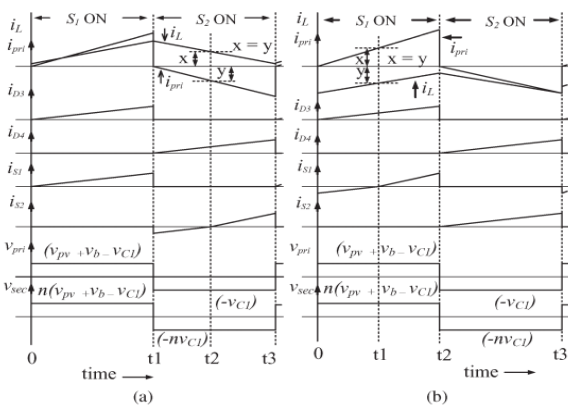

Fig. 4. Waveforms of currents flowing through and voltage across different key circuit elements of TCDIC when (a) i_L is positive and (b) i_L is negative.

is employed for ensuring the MPP operation of the PV array, which leads to the improved utilization of the converters involved. Furthermore, only one converter stage is present in the path between the PV array and the battery, thereby increases the charging efficiency of the battery. The inductor current i_L is designed to be continuous. The switches S_1 and S_2 are operated in complementary fashion. All semiconductor devices and passive elements are assumed to be ideal in the following analysis.

A. Operation of the Converter When Inductor Current is Positive

The waveforms of the currents flowing through and voltages across different key circuit elements of TCDIC, while the current flowing through the inductor L is positive, are shown in Fig. 4(a). The various possible switching modes during this condition are analyzed in this section.

a) Mode I (0 to t_1 ; S_1 and D_3 conducting): When S_1 is turned on, the PV array voltage V_{PV} is impressed across L , and the inductor current i_L increases. During this period, the voltage impressed across the primary winding of the transformer is $V_{PRI} = (V_{PV} + V_B - V_{C1})$, wherein V_B is the battery voltage and V_{C1} is the voltage across the capacitor C_1 . Hence, the primary current of the transformer, i_{pri} , increases, and the capacitor C_1 gets charged. The current flowing through the secondary

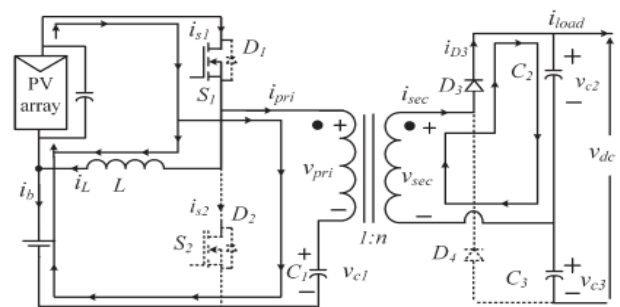

Fig. 5. Equivalent circuit diagram of TCDIC when operating in mode I and inductor current is positive.

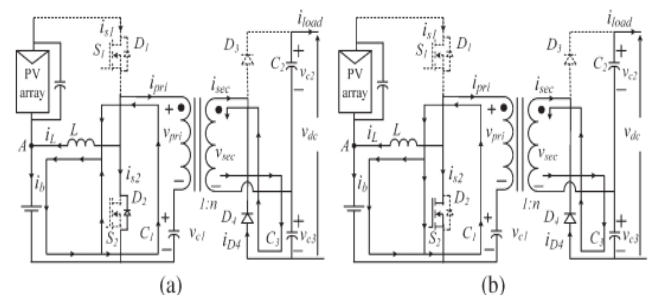

Fig. 6. Equivalent circuit diagram of TCDIC when inductor current is positive: (a) Mode II and (b) mode III.

Winding of the transformer, i_{SEC} , also increases. The diode D_3 is forward biased, and the capacitor C_2 gets charged. The voltage across C_2 is given by $v_{C2} = n(V_{PV} + V_B - V_{C1})$, wherein n is the turns ratio of the transformer. The equivalent diagram of TCDIC during this mode is shown in Fig.5.

b) Mode II (t_1 to t_2 ; D_2 and D_4 conducting): This mode begins when S_1 is turned off and S_2 is turned on. At the starting of this mode, i_L is positive, and as S_1 is turned off, i_{PR} is zero. Since $i_L > i_{PRI}$, the diode D_2 starts conducting.

The voltage impressed across L is $V_L = -V_B$, and hence, i_L starts decreasing. The voltage impressed across the primary winding of the transformer is $V_{PR} = -V_{C1}$, and hence, i_{PRI}

becomes negative and starts decreasing, thereby discharging C1. The current flowing through the secondary winding of the transformer, I_{sec} , reverses, and the diode D4 gets turned on. The capacitor C3 is getting charged, and the voltage across C3 can be expressed as $V_{C3} = n(V_{C1})$. During this mode, $I_L > (-I_{PRI})$ and diode D2 is forward biased. This mode continues until I_L becomes equal to $(-I_{PRI})$. The equivalent circuit diagram of TCDIC during this mode is shown in Fig. 6(a).

c) Mode III (t2 to t3; S2 and D4 conducting): When i_L becomes smaller than $(-I_{PRI})$, the diode D2 is reverse biased, and the switch S2 starts conducting. The rest of the operation remains the same as that of mode II. The equivalent circuit diagram of TCDIC during this mode is shown in Fig. 6(b).

B. Operation of the Converter When Inductor Current is Negative

The waveforms of the currents flowing through and voltages across different key circuit elements of TCDIC, while the current flowing through the inductor L is negative, are shown in Fig. 6(b). The various possible switching modes during this condition are analyzed in this section.

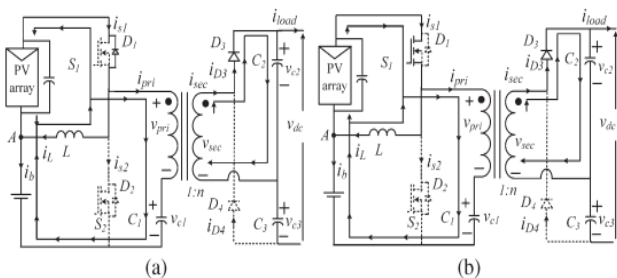

Fig. 7. Equivalent circuit diagram of TCDIC when inductor current is negative: (a) Mode I and (b) mode II.

d) Mode I (0 to t1; D1 and D3 conducting): This mode begins when S1 is turned on and S2 is turned off. At the starting of this mode, i_L is negative, and I_{PRI} is zero. Hence, the diode D1 starts conducting. The rest of the operation is the same as that of mode I discussed in the previous section. This mode continues until I_{PRI} becomes equal to $(-i_L)$. The equivalent circuit diagram of TCDIC during this mode is shown in Fig. 7(a).

e) Mode II (t1 to t2; S1 and D3 conducting): When i_{pri} becomes greater than $-i_L$, the diode D1 is reverse biased, and the switch S1 starts conducting. The rest of the operation is the same as that of mode I seen in the previous section. The equivalent circuit diagram of TCDIC during this mode is shown in Fig. 7(b).

f) Mode III (t2 to t3; S2 and D4 conducting): This mode begins when S1 is turned off and S2 is turned on. During this mode, both i_L and i_{pri} are negative, and the switch S2 conducts. The negative current in the primary winding of the transformer results in negative current in the secondary

winding of the transformer. Hence, the diode D4 is forward biased, and the capacitor C3 gets charged. During operation in this mode, $V_L = -V_b$, $V_{PRI} = -V_{CL}$, and $V_{C3} = nV_{C1}$. The equivalent circuit diagram of TCDIC during this mode is the same as that shown in Fig. 6(b), except that the direction of i_L is reversed. From Fig. 3, the voltage v_L across the inductor L can be expressed as

$$v_L = v_{pv}, \quad \text{when } S_1 \text{ is on}$$

$$v_L = -v_b, \quad \text{when } S_2 \text{ is on} \quad (1)$$

Therefore, the average voltage drop across the inductor is

$$V_L = DV_{pv} - (1 - D)V_b$$

Wherein D is the duty ratio of the switch S1. Equating the average voltage drop across the inductor to zero,

$$V_{pv} = \left[\frac{(1 - D)}{D} \right] V_b \quad (2)$$

From (2), it can be inferred that the PV voltage can be controlled by manipulating D as battery voltage V_b can be assumed to be a stiff source. Therefore, the MPPT operation of the PV array can be achieved through a proper manipulation of D. The average output voltage of the TCDIC, V_{dc} , is given by

$$V_{dc} = (V_{C2} + V_{C3})$$

$$= [n(V_b + V_{pv} - V_{C1}) + nV_{C1}]$$

$$= n(V_b + V_{pv}). \quad (3)$$

Applying KCL at point A of Fig. 3,

$$i_L + i_{cpv} = i_b + i_{pv} \quad (4)$$

Considering the average values of I_L , I_{cpv} , I_b , and I_{pv} over a switching cycle and noting that $I_{cpv} = 0$, (4) transforms to

$$I_b = I_L - I_{pv} \quad (5)$$

From (5), it can be noted that, for $I_L > I_{pv}$, the battery is charged and, for $I_L < I_{pv}$, the battery is discharged. Therefore, by controlling I_L , for a given I_{pv} , battery charging and discharging can be controlled. The drawback of TCDIC and the associated design constraints are presented. The details of the control strategy devised for TCDIC are discussed.

3. CONTROL STRUCTURE

The controller of a stand-alone system is required to perform the following tasks: 1) extraction of maximum power from the PV array; 2) manipulate the battery usage without violating the limits of overcharge and over discharge; and 3) dc-ac conversion while maintaining the load voltage at the prescribed level. A controller is devised for misrepresenting the TCDIC to realize the first two aforementioned objectives, while the third objective is achieved by employing a conventional proportional integral (PI) controller to control the output voltage of the full bridge inverter through sinusoidal pulse width modulation. As the conventional control scheme is used for controlling the output voltage of the inverter, its design issues are not discussed in this paper. The details of the control algorithm

devised for TCDIC are presented in this section. In order to achieve the desired functions, TCDIC is required to operate in one of the following modes.

3.1 MPPT mode: Maximum power is extracted from the PV array when the system is operating in this mode. However, in order to operate in this mode, one of the following conditions must be satisfied: 1) Available maximum PV power P_{mpp} is more than the load demand PI , and the surplus power can be consumed by the battery without being overcharged; and 2) $P_{mpp} < PI$ and the battery have the capability to supply $PI - P_{mpp}$ without being over discharged. The PV power in MPPT mode is given by $P_{pv} = P_{mpp} = (P_b + PI)$, where P_b is the battery power which is defined as positive during charging and negative while discharging.

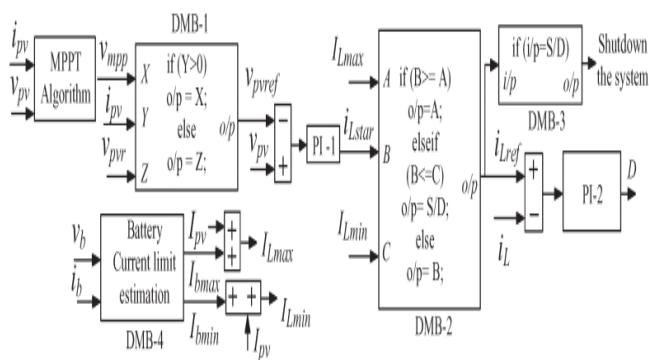

Fig. 8. Control structure for the proposed TCDIC.

3.2 Non-MPPT mode: Based on the state of charge (SOC) level of the battery, its charging current is required to be limited to a maximum permissible limit $I_b \max$ to prevent the battery from getting damaged due to overcharge. The maximum charging current limit $I_b \max$ restricts the maximum power that can be absorbed by the battery to $P_b \max = I_b \max * V_b$. When $P_{mpp} > PI$ and the surplus power is more than $P_b \max$, the system cannot be operated in MPPT mode as it would overcharge the battery. During this condition, power extraction from PV is reduced to a value given by $P_{pv} = (P_b \max + PI)$. This mode of operation is known as non-MPPT mode.

3.3 Battery only (BO) mode: The system operates in BO mode when there is no PV power and the battery has the withstand to supply the load demand without being overdischarged.

3.4 Shutdown mode: When $P_{mpp} < PI$ and the battery does not have the capability to supply $PI - P_{mpp}$, the system needs to be shut down to prevent the battery from being over discharged.

The control algorithm that is employed to select the proper mode of operation for the TCDIC, depending on the status of the SOC of the battery $v_{is} - a - v_{is}$ the availability of power from the solar array, is shown in Fig.8. The proper mode selection is done by four logical decision-making blocks (DMBs). The control block DMB-1 sets the reference for the PV array

voltage ($V_p v_{ref}$). It also decides whether the system will operate in BO mode or in MPPT mode. When it is found that $i_{pv} > 0$, thereby indicating the availability of PV power, the MPPT mode of operation is selected, and the output of the MPPT algorithm block (i.e., V_{pmppt}) sets $V_p v_{ref}$. When the PV power is not available, the BO mode is selected, and V_{pvref} is taken as $V_p v_r$ wherein V_{pv} is selected so as to maintain the output voltage V_{dc} within the desired range of 350–460 V as per (3). The error between V_{pvref} and $V_p v$ is passed through a PI controller to set the required reference for the inductor current (i_{Lstar}). An upper limit $I_L \max$ and a lower limit $I_L \min$ is imposed on i_{Lstar} based on the relationship given in (5) to prevent overcharging and over discharging of the battery, respectively. These two limits are derived as follows:

$$I_L \max = I_b \max + I_{pv}$$

$$I_L \min = I_b \min + I_{pv}$$

Wherein $I_b \max$ and $I_b \min$ are the maximum permissible charging and discharging current of the battery, respectively. These two limits are set based on the SOC level and the allowable depth of discharge of the battery. The block DMB-4 is employed to carry out the aforementioned functions. The block DMB-2 sets the reference level for the inductor current i_{Lref} after resolving the constraints imposed by $I_L \max$ and $I_L \min$.

When i_{Lref} remains within its prescribed limit, the system operates either in MPPT mode (for $i_{pv} > 0$) or in BO mode (for $i_{pv} \leq 0$). When i_{Lref} hits its lower limit, thereby indicating that the over discharge limit of the battery is reached, DMB-3 withdraws gating pulses from all the switches and shuts down the system. When the battery overcharging limit is attained, i_{Lref} hits its upper limit. This situation arises only when the system is operating in MPPT mode with $P_{mpp} > PI$ and the surplus power is more than $P_b \max$. In this condition, i_{Lref} is limited to $I_L \max$ to limit the battery charging current to $I_b \max$, and the MPPT is bypassed. As the battery charging current is limited to $I_b \max$, power consumed by the battery is restricted to $P_b \max$. This makes the available PV power more than $(PI + P_b \max)$. This extra PV power starts charging the PV capacitor, and its voltage increases beyond V_{mpp} , thereby shifting the PV operating point toward the right side of the MPP point, and the power extracted from the PV array reduces. This process continues until the power drawn from the PV array becomes equal to $(PI + P_b \max)$. Hence, during operation of the system in non MPPT mode, the PV array is operated at a point on the right side of its true MPP, and hence, $P_{pv} < P_{mpp}$. If there is a decrement in load demand while operating in non-MPPT mode, power drawn from the PV array becomes more than $(PI + P_b \max)$, and this excess power drawn starts charging the PV capacitor, thereby moving the operating point of the PV further toward the right side of its previous operating point. In case of an increment in the load demand, the power drawn from the PV array falls short of supplying the load demand and the dc-link capacitors, and the PV capacitor starts discharging. As the voltage of the PV capacitor falls,

the operating point of the PV array shifts toward the left side from its previous operating point. This leads to an increase in the power drawn from the PV array, and this process continues until the power balance is restored. In case the load demand increases to an extent such that the PV power available at its MPP falls short to supply this load, the battery will come out of its charging mode, i_{Lref} will become less than I_{Lmax} , and the system operates in MPPT mode.

4. MATLAB/SIMULATION RESULTS

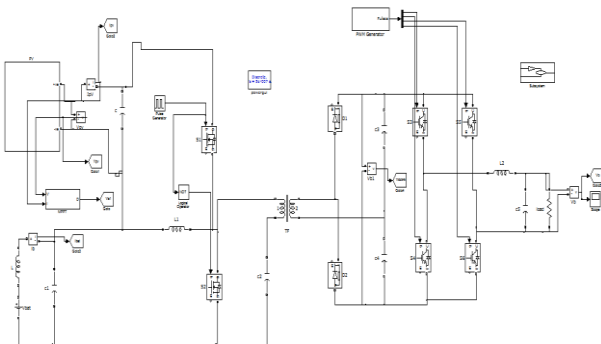

Fig.9. Matlab/Simulation model of under steady-state operation.

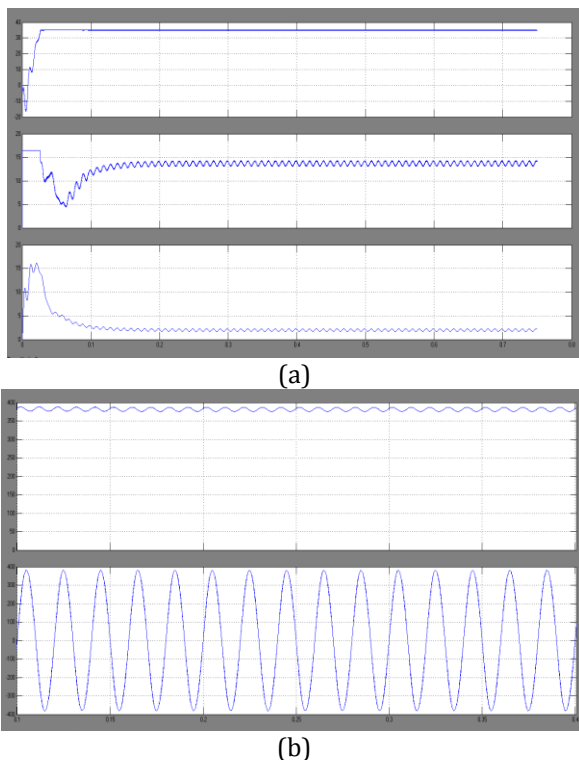

Fig. 10. Simulated response of the system under steady-state operation in MPPT mode. (a) v_{pv} , i_{pv} , and i_b . (b) v_{dc} and load voltage.

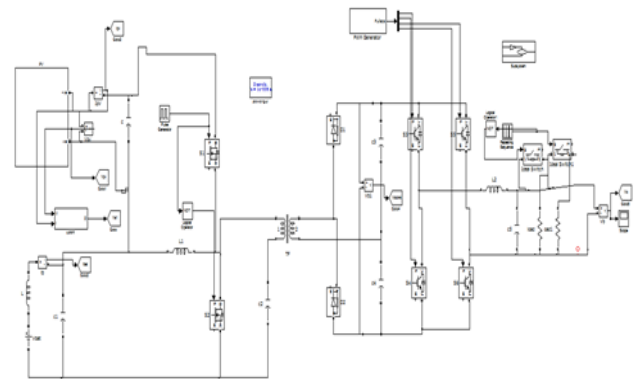

Fig.11. Matlab/Simulation model of under changes in load and isolation level while operating in MPPT mode.

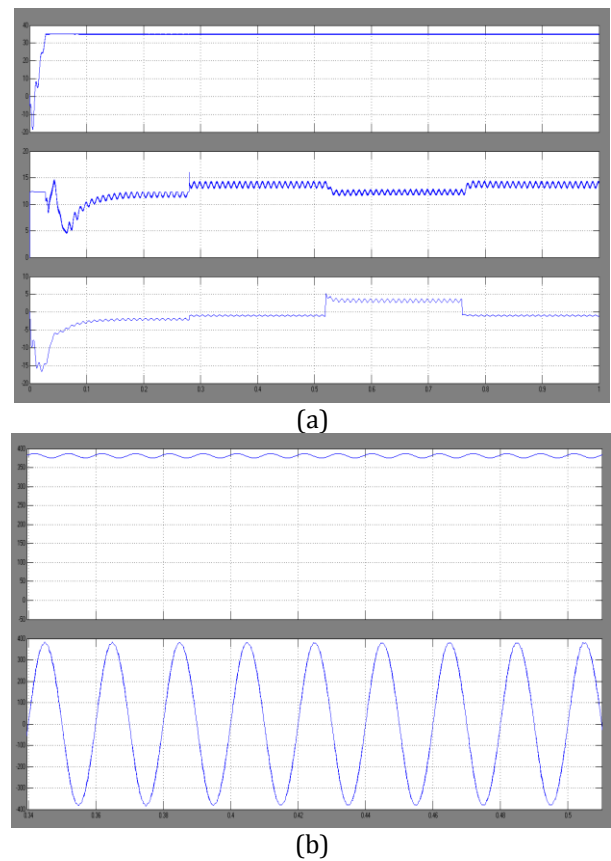

Fig. 12. Simulated response of the system under changes in load and isolation level while operating in MPPT mode. (a) v_{pv} , i_{pv} , and i_b . (b) v_{dc} and load voltage.

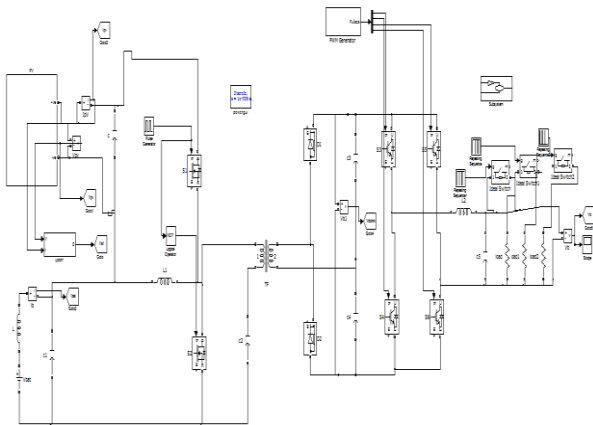
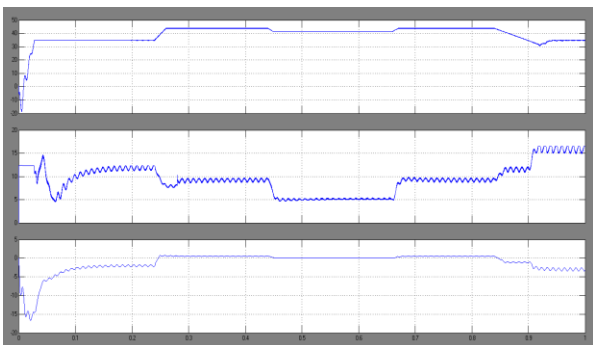
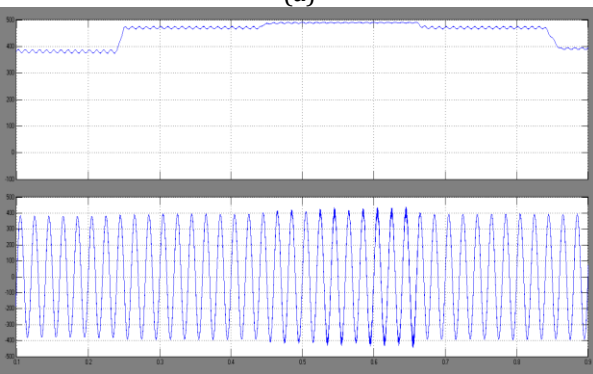

Fig.13. Matlab/Simulation model of under mode transition between MPPT and non MPPT mode and the effect of load change in non-MPPT mode.



(a)



(b)

Fig. 14. Simulated response of the system under mode transition between MPPT and non-MPPT mode and the effect of load change in non-MPPT mode. (a) vpv, ipv, and ib. (b) vdc and load voltage.

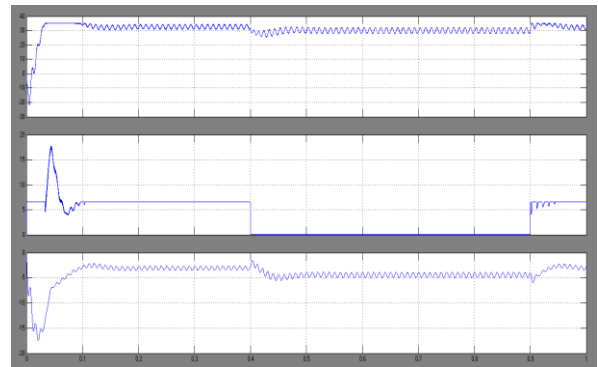

(a)

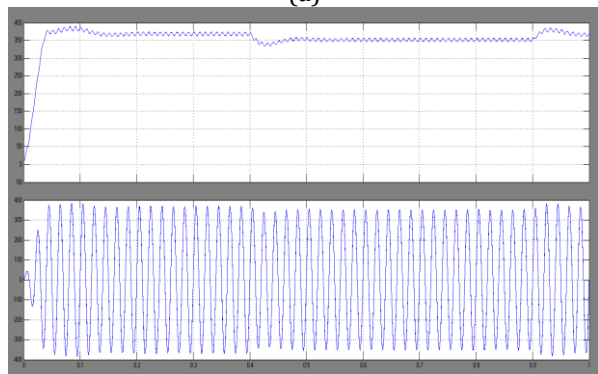

(b)

Fig. 15. Response of the simulated system during mode transition between MPPT and BO modes. (a) vpv, ipv, and ib. (b) vdc and load voltage.

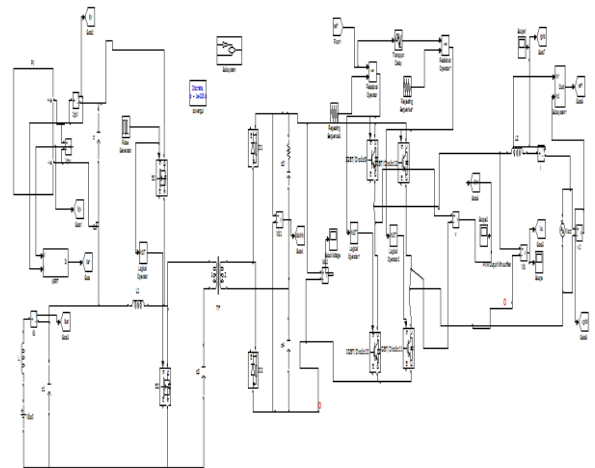
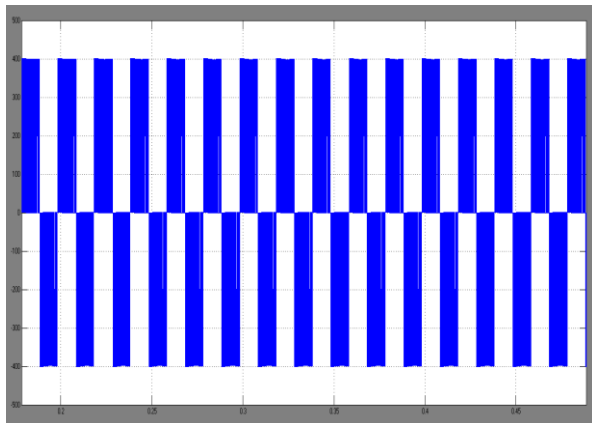
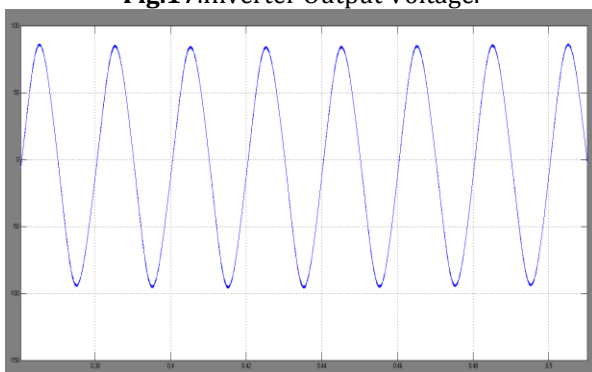

Fig.16.Matlab/Simulation model of under grid connected system.

Fig.17.Inverter Output Voltage.

Fig.18.Grid Current.

5. CONCLUSION

A solar PV-based stand-alone scheme for application in rural areas is proposed in this paper. It is realized by involving a new TCDIC followed by a conventional full-bridge dc to ac inverter. Performances of the management in real conditions strongly depend of the accuracy of the forecasts and of the mode of operation. This important conclusion leads to many questions about reactive power management without denying the importance and the necessity of the predictive optimization stage. The management developed helps integration of PV power into the grid as peak loads are shaved. Depending of the reactive management in real conditions, the power fluctuation of the PV production is balanced to the power exchanged with the grid or with the batteries. In this context, next and future works will deal with reactive management for real condition operations. The management developed helps integration of PV power into the grid as peak loads are shaved. Depending of the reactive management in real conditions, the power fluctuation of the PV production is balanced to the power interchanged with the grid or with the batteries.

REFERENCES

[1]. Hamid R. Teymour, Danny Sutanto, Kashem M. Muttaqi, and P. Ciufo, –Solar PV and Battery Storage Integration using a New Configuration of a Three-Level NPC Inverter With Advanced Control Strategy ||IEEE transactions on energy conversion, vol. 29, no. 2, June, 2014.

[2]. O. M. Toledo, D. O. Filho, and A. S. A. C. Diniz, –Distributed photovoltaic generation and energy storage systems: A review,|| Renewable Sustainable Energy, Rev., vol. 14, no. 1, pp. 506–511, 2010.

[3]. M. Bragard, N. Soltau, S. Thomas, and R. W. De Doncker, –The balance of renewable sources and user demands in grids: Power electronics for modular battery energy storage systems,|| IEEE Trans. Power Electron., vol. 25, no. 12, pp. 3049–3056, Dec. 2010.

[4]. Muhammad H. Rashid, –Power electronics circuits, devices and applications|| Pearson education, 3rd edition, 2004.

[5]. Lewicki, Z. Krzeminski, and H. Abu-Rub, –Space vector pulse width modulation for three-level n_{pc} converter with the neutral point voltage control,|| IEEE Trans. Ind. Electron., vol. 58, no. 11, pp. 5076–5086, Nov., 2011.

[6]. M. Miyatake, M. Veerachary, F. Toriumi, N. Fujii, and H. Ko, “Maximum power point tracking of multiple photovoltaic arrays: A PSO approach,” IEEE Trans. Aerosp. Electron. Syst., vol. 47, no. 1, pp. 367–380, Jan. 2011.

[7]. J. T. Stauth, M. D. Seeman, and K. Kesarwani, “Resonant switched capacitor converters for sub-module distributed photovoltaic power management,” IEEE Trans. Power Electron., vol. 28, no. 3, pp. 1189–1198, Mar. 2013.

[8]. T. Shimizu, M. Hirakata, T. Kamezawa, and H. Watanabe, “Generation control circuit for photovoltaic modules,” IEEE Trans. Power Electron., vol. 16, no. 3, pp. 293–300, May 2001.

[9]. H. J. Bergveld et al., “Module-level dc/dc conversion for photovoltaic systems: The delta-conversion concept,” IEEE Trans. Power Electron., vol. 28, no. 4, pp. 2005–2013, Apr. 2013.

[10]. P. S. Shenoy, K. A. Kim, B. B. Johnson, and P. T. Krein, “Differential power processing for increased energy production and reliability of photovoltaic systems,” IEEE Trans. Power Electron., vol. 28, no. 6, pp. 2968–2979, Jun. 2013.

[11]. J. H. Wohlgemuth and S. R. Kurtz, “How can we make PV modules safer?” in Proc. 38th IEEE Photovoltaic Spec. Conf., 2012, pp. 3162–3165.

[12]. W. Li and X. He, “Review of non-isolated high-step-up dc/dc converters in photovoltaic grid-connected applications,” IEEE Trans. Ind. Electron., vol. 58, no. 4, pp. 1239–1250, Apr. 2011.

[13]. H. Wang and D. Zhang, “The stand-alone PV generation system with parallel battery charger,” in Proc. IEEE ICECE, Jun. 2010, pp. 4450–4453.