

Image Processing based Induction Motor Fault Detection using LabVIEW

Miss. Kalyani S. Digdeotulwar¹, Dr. A .U.Jawadekar²

¹ME(EPS)Student, Department of Electrical Engineering, SGBAU, SSGMCE, Shegaon, Maharashtra, India

²Professor, Department of Electrical Engineering, SGBAU, SSGMCE, Shegaon, Maharashtra, India

Abstract - Stator winding breakdown causes failure of induction motors which results in plant shut down, reduced production, accidents etc. in the production. Early diagnosis improves the safety of the operator and minimizes the maintenance cost. In this paper our aim is fault detection of induction motor based on image processing using particle analysis. This method uses image identification of the stator current Concordia patterns. A feature based recognition of stator pattern current independent of their shape, size and orientation is the goal of the proposed method. A LabVIEW simulation has been carried out to detect the stator faults present in the Induction Motor.

Key Words: Induction Motor, Fault Detection, LabVIEW, Image Processing, Park's Vector Approach, stator current

1. INTRODUCTION

Induction Motors are a critical component of many industrial processes and are frequently integrated in commercially available equipment and industrial processes. Three phase AC induction motors are probably the most common type of three phase load and are used in a variety of equipment including refrigeration, pumps, air conditioning, conveyor drives as well as their more obvious applications. The induction motors are most widely used motors in industrial, commercial and residential sectors. Motor-driven equipment often provide core capabilities essential to business success and to safety of equipment and personnel. Induction motors play a very important role in the safe and efficient running of industrial plants and processes. Early detection of abnormalities in the motors will help avoid expensive failures. There are many published techniques and many commercially available tools to monitor induction motors to insure a high degree of reliability uptime. In spite of these tools, many companies still face unexpected system failures and reduced motor lifetime. This paper deals with fault detection of induction motor based on image processing using LabVIEW. This method is based on the image identification of the stator current Concordia patterns. A feature- based recognition of stator current independent of their shape, size and orientation is the goal of the proposed method. This paper comprises of following sections. Section II represents the Park's Vector Approach technique. Section III gives details of Image Processing in which Image composition, Particle analysis and Feature extraction are further carried out. Section IV presents experimental setup. Section V discusses LabVIEW Simulink model and result. And finally section VI is concluded with conclusion.

2. PARK'S VECTOR APPROACH

In three-phase induction motors, we know that the connection to the mains does not usually use the neutral. Hence to describe induction motor in three phase, we need to represent this phenomenon in two dimension first. This 2D representation works on the current Concordia vector which is known as Park's Vector.

The current Concordia vector components (i_α , i_β) are a function of mains phase variables (i_a , i_b , i_c) as:

$$i_\alpha = \sqrt{\frac{2}{3}} i_a - \frac{1}{\sqrt{6}} i_b - \frac{1}{\sqrt{6}} i_c$$

$$i_\beta = \frac{1}{\sqrt{2}} i_b - \frac{1}{\sqrt{2}} i_c$$

In ideal conditions, three-phase currents lead to a Clark-Concordia vector with the following components:

$$i_{\alpha} = \frac{\sqrt{6}}{2} I \sin \omega t$$

Where 'I' denotes the supply phase current's maximum value and 'ω' denotes supply frequency. The current Park components are then calculated by the following expression:

$$\begin{bmatrix} I_d \\ I_q \end{bmatrix} = \begin{bmatrix} \cos \theta_s & \sin \theta_s \\ -\sin \theta_s & \cos \theta_s \end{bmatrix} \begin{bmatrix} I_{\alpha} \\ I_{\beta} \end{bmatrix}$$

3. IMAGE PROCESSING

Image processing is a method in which an image needs to be converted into digital form and number of operations are performed on it so that an enhanced image can be derived and useful information can be extracted from it. In this process input can be in the form of image with resulting output in the form of image with its more profound and sorted characteristics. The proposed image processing is divided into three stages: image composition, particle analysis and feature extraction as shown in Figure.3 The inputs for the image processing based system are the αβ currents and the outputs are I.O.C

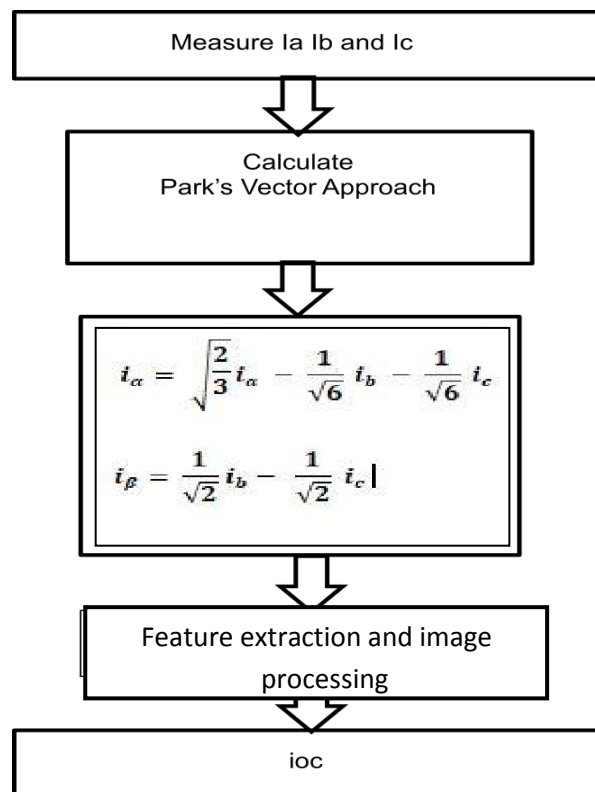

Figure : 3 Flowchart of Image Processing in fault detection of induction motor

3.1 Image Composition

In the image composition stage, the Id Iq stator currents are first represented as an image in order to be used in the pattern recognition method.

3.2 Particle analysis-

In the pattern recognition method, after finding image composition the next step is to determine the shape of the region. To show the boundary of the region and at the same time find some properties which help in feature extraction, the NI vision

particle analysis palette is used. This method results in an efficient calculation of the region area and its contour perimeter. During the contour following right and left upper points (tr_p, tl_p) of the region were obtained using particle measurement of first pixel through which the last pixel on the first line of the region.

3.3 Feature Extraction

The feature extraction stage uses the area of the object and the contour perimeter to calculate the index of compactness. For the difference between the Healthy and Inter turn fault condition it is necessary to find some features. The images of Id Vs Iq obtained in Simulation are standard forms such as Circle and Ellipse. So considering the shapes obtained in both the cases the features changes accordingly. But for the detailed discrimination the Area, Perimeter and Eccentricity of the image for every case is calculated.

3.4 Finding Area, Perimeter and Eccentricity

Obtain the handles of Id Vs Iq plot and its coordinates. Also find the maximum and minimum X, Y coordinate of plot. Obtain major and minor axis from the plot and also find its semi major and semi minor axis plots. Calculate the eccentricity using 'axes2ecc' function in MATLAB. Calculate area under the image by using formula

Area = $\pi * \text{Semi-major axis} * \text{Semi-minor axis}$. Calculate perimeter of the image by using formula $\text{Perimeter} = 2 * \pi * \{(\text{semi-major axis}^2 + \text{semi-minor axis}^2) / 2\}$

The images of Id Vs Iq found from the simulation model are in standard form representing Circle, Oval Shaped Image and Parabola but because of power quality problems the Stator current waveforms are in distorted manner which affects the Id Vs Iq plot. Now we are considering some features such as Area and Pixel value which are applicable and used for any non standard patterns. The problem regarding the features of Star shaped Image is solved by taking Area and Pixel value as feature.

4. EXPERIMENTAL SETUP

In order to achieve the fault detection of induction motor a modern laboratory test bench set up is shown in figure 4. The set up used for the experimental purpose consists of 2 Hp, 3 phases; 50 Hz; 415 V; 1350 rpm; 3.6 Amp star connected squirrel cage induction motor made by the leading Indian Electrical industry is used for the analysis of bearing fault and broken rotor bar faults. The Induction motor is coupled with D.C. generator having 4 poles; 230 volt; 9.6 Amp current rating. The induction motor is loaded from no load to full load. The current signals are captured at sampling frequency of 1 KHz with the help of ADLINK DAQ which is shown in Figure 4. The Different experiments are carried out on laboratory test bench in healthy condition and stator inter turn (20 turn) fault.

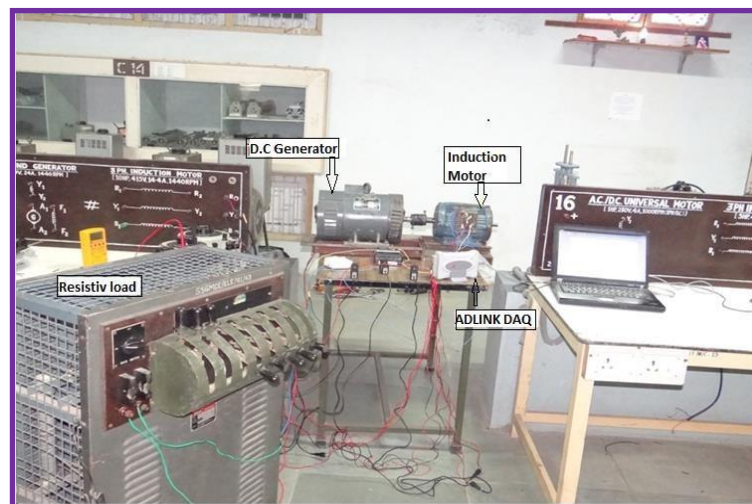

Figure : 4 Experimental setup

Signals were captured for healthy and faulty conditions:

1. Healthy motor
2. Inter turn (20 turn) fault

1. Healthy motor:

The motor operates in normal operation. The stator current signals and phase voltages are captured.

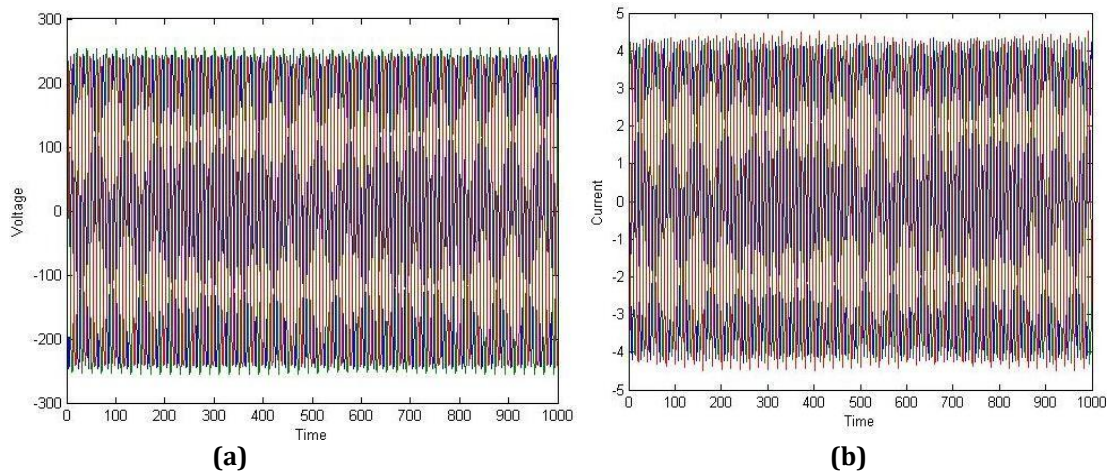

Figure 4.1 (a) and (b) represents phase voltage and stator current graph for healthy condition

2. Inter turn (20 turn) fault:

For Inter turn fault twenty turns are short circuited. Due to this current increases which indicates that fault was present.

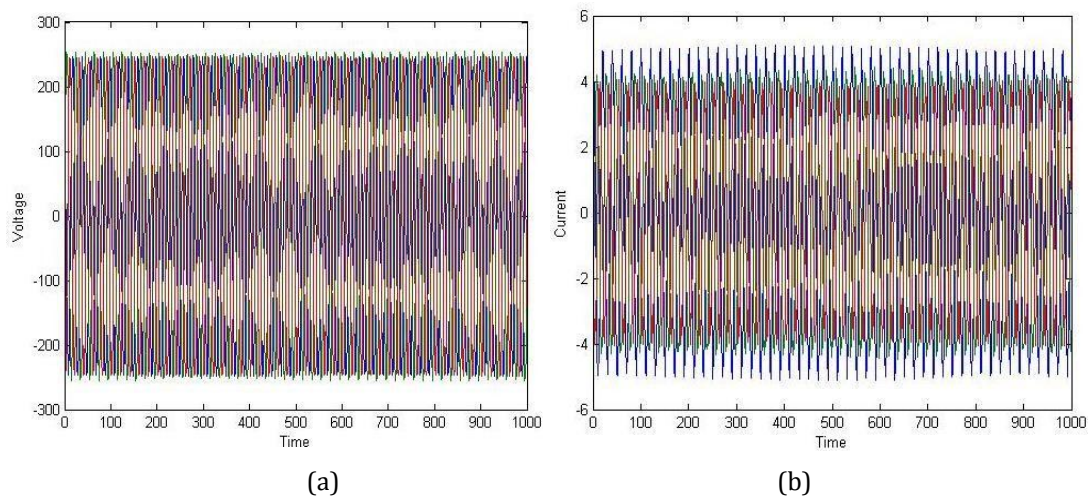

Figure 4.2 (a) and (b) represents phase voltage and current graph for Inter turn (20 turn) stator fault

5. LABVIEW SIMULINK MODEL, RESULT AND DISCUSSION

Before implementing any method in practical it is beneficial to study it on software model as it gives us brief idea regarding the implementation of method in practical experimentation.

LabVIEW simulink Model

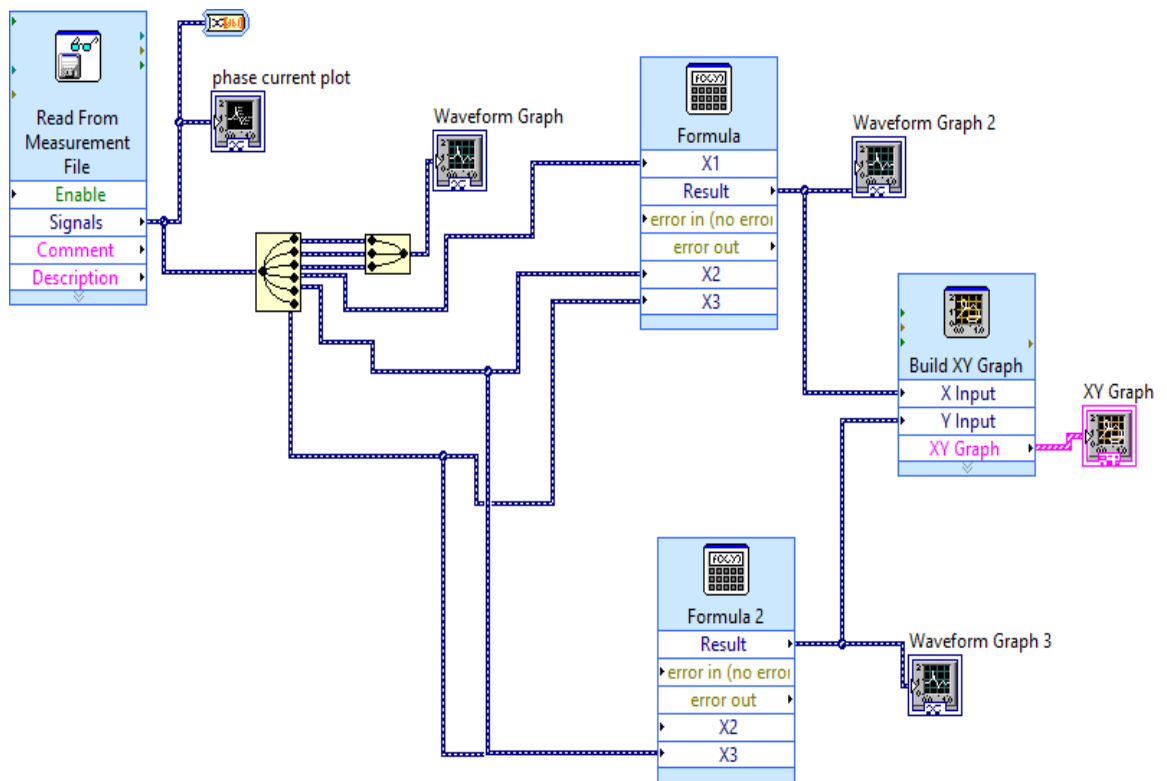

Figure : 5 LabVIEW Graphical code

6. RESULTS

The following graphs represent the voltage and current signals captured for healthy condition:

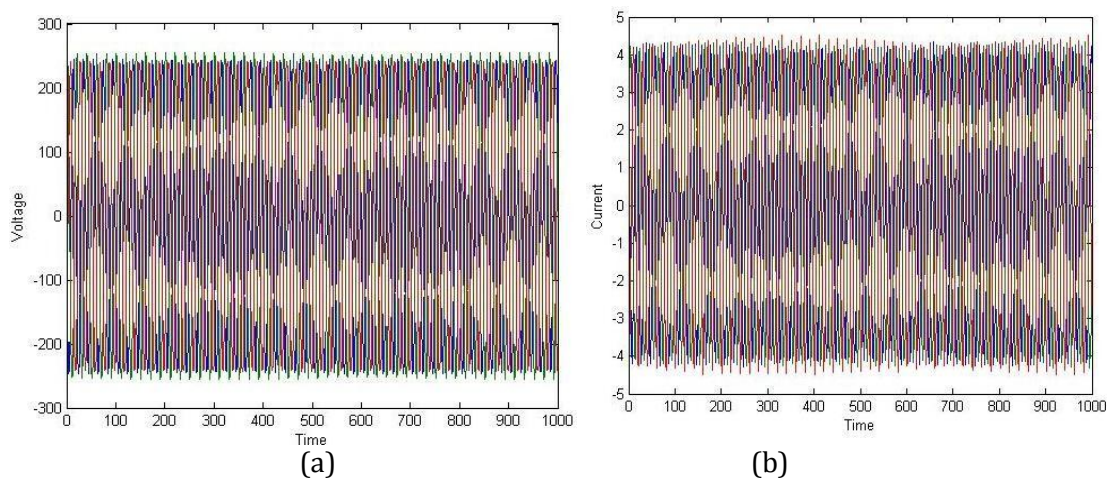

Figure: 6.1(a) and (b) represents voltage and current graph for healthy condition

The following graphs represent the fig for voltage and current for faulty condition:

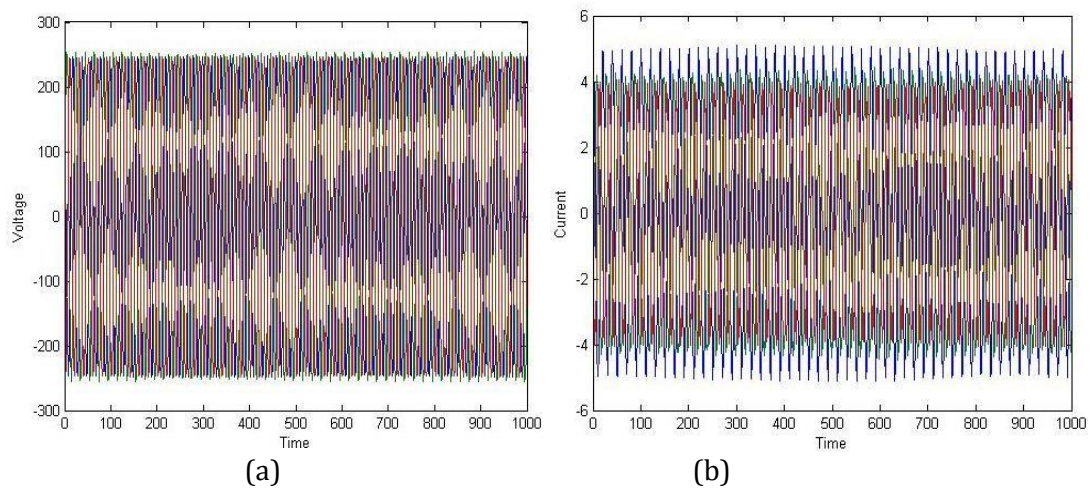

Figure: 6.2 (a) and (b) represents voltage and current graph for Inter turn (20 turn) stator fault

The following graphs are the representation of stator current I_d and I_q under healthy and faulty condition. We can see that in Faulty condition the graph is in an elliptical form compared to healthy condition.

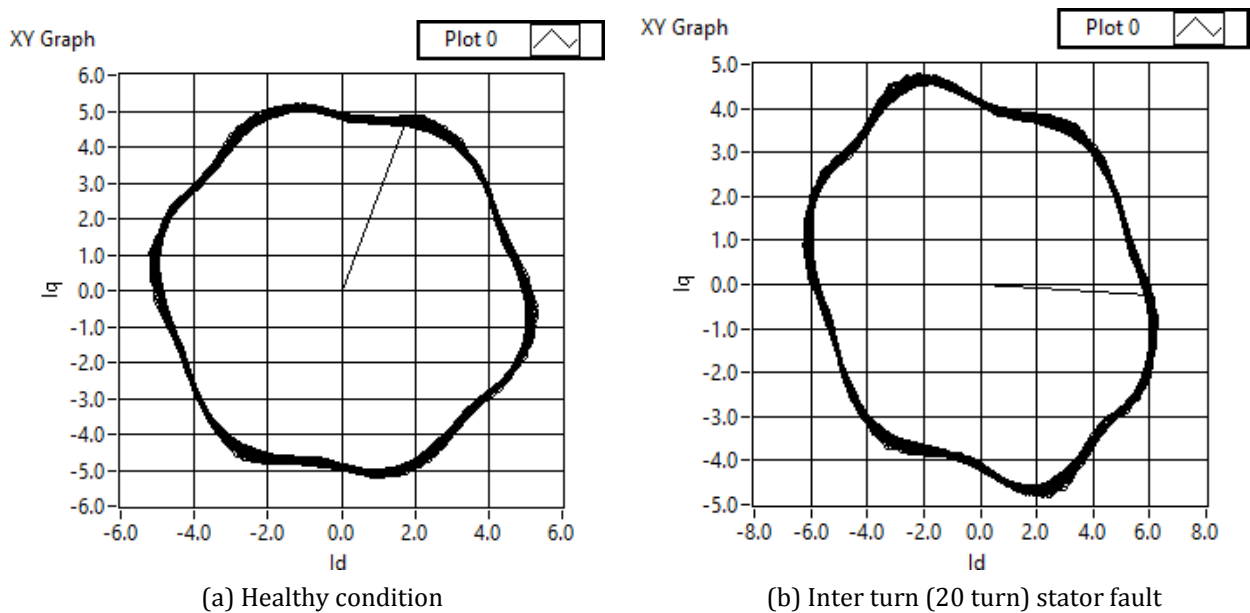

Figure : 6.3 (a), (b) represents I_d , I_q graphs of stator current in LabVIEW

Table: 6.4 Parameters calculated for Healthy and Faulty conditions

	Healthy Condition		Inter turn (20 turn) fault	
Area	5.992	5.497	8619.883	7158.406
Eccentricity	0.044	0.070	4.648666	4.089367
Perimeter	0.436	0.626	659.988	661.520
Pixel Value	165	189	761	782
IOC	5.992037	5.49744	8619.883	7158.406

7. CONCLUSION

Through Park's Vector Approach stator current I_d , I_q plot is generated. After calculating various parameters such as Area, Eccentricity, Perimeter and IOC, It is clear that stator turn fault was present. These parameters can be used to identify healthy condition from the Inter turn (20 turn) fault condition. A healthy three-phase induction motor generates a circular pattern. Eccentricity increases with severity of fault. Hence the I_d , I_q plot is elliptical in Inter turn fault condition. Differences can also be seen in the parameters calculated in table 6.4. These parameters are further used to classify the healthy and faulty condition.

REFERENCES

- [1] G. M. Joksimovic and J. Penman, "The Detection of Inter-turn Short Circuits in the Stator Windings of Operating Motors, IEEE Transactions on Industrial Electronics, vol. 47, no. 5, October, pp. 1078-1084, 2000.
- [2] Mohamed El Hachemi Benbouzid, "A Review of Induction Motors Signature Analysis as a Medium for Faults Detection", IEEE Transaction on Industrial Electronics, vol. 47, no. 5, pp. 984-993, October, 2000.
- [3] S. SwarnaLatha, R.Mahesh / International Journal of Engineering Research and Applications (IJERA) ISSN: 2248-9622 www.ijera.com Vol. 2, Issue5, September- October 2012, Image Processing Based Stator Fault Severity Detection and Diagnosis of Induction Motor Using Labview
- [4] B. M. El Hadremi, "A review of induction motor signature analysis as a medium for fault detection", IEEE Trans. on Ind. Electron., vol. 47, pp 984-993, Oct. 2000.
- [5] S. Schoen, B. Lin, T. Habetler, J. Schlag, S. Farag, "An Unsupervised, On-Line System for Induction Motor Fault Detection Using Stator Current Monitoring," IEEE Trans. on Ind. Applications, vol. 31, no 6, pp. 1280-1286, Nov./Dec. 1995.
- [6] A. J. M. Cardoso, S. M. A. Cruz, and D. S. B. Fonseca, "Inter-turn stator winding fault diagnosis in three-phase induction motors, by Park's Vector Approach," IEEE Trans. Energy Conversion, vol. 14, pp. 595- 598, Sept. 1999.
- [7] NI Vision Concepts manual.