

ANIMAL COUNTING AND DETECTION USING CONVOLUTIONAL NEURAL NETWORK

Darshanraj N¹, Prathik K²

¹Student, Dept. of Computer Science and Engineering, Bangalore Institute of Technology, Karnataka, India

²Student, Dept. of Information Science and Engineering, Bangalore Institute of Technology, Karnataka, India

Abstract - This is the research to study alternative technologies for automatically counting live sheep, particularly as they are loaded on and off ships, and to carry out preliminary development of the most promising concept. The technologies investigated included machine vision, radio frequency tags, and races capable of singulations sheep mechanically. At present, all these sheep are counted by manual method several times, not only in the departure lanes but also in the lottery where sheep are kept for weeks before being exported. Automating the detection and identification of animals is a task that has an interest in livestock subsector. The most common and redundant job of a rancher or herdsman is counting their herd to derive a headcount so they can determine livestock availability. It's a task that's done once a day, every day. It takes a large amount of the rancher's or herdsman's time and thus an automated solution for identification and reckoning of livestock using image processing using Convolutional Neural Network is proposed. BLOB is used to store information in the database.

Key Words: Machine vision, Radio frequency tags, Singulations, Image processing, BLOB, Convolutional Neural Network.

1. INTRODUCTION

Livestock subsector has an enormous contribution to developing countries economy, especially in the provision of food for the growing human population, supply of raw materials to the industrial sector, a good (AGDP), and about 40% of the global GDP and serves as the fastest growing agricultural market, a major contributor to food and as well as serving as a vital source of employment for almost 1 billion poor people. Animals division incorporates creature cultivation, dairy and fisheries part are extensive significant segments. It assumes a significant function in public economy and social financial advancement of the nation. It additionally assumes significant function in the provincial economy as enhancing family earnings and creating productive work in the country area. Indian livestock industry makes up for a significant amount of world's livestock resources. As animals come and go in their daily routine they are

counted as they come in close enough proximity to the counter. Instead of driving into a pasture or field and interactively counting a herd. If the number displayed is less than the known headcount the rancher or herdsman could either do a manual headcount or check the counter again later in the day and transmission of a head count from a remotely operation system, are possible. However, there is rapid growth in demand for livestock and livestock products, in developing countries, which is viewed as a food revolution. The most common and redundant job of a rancher or herdsman is counting their head to derive a headcount so they can determine livestock availability. It's a task that's done once a day, every day. It takes a large amount of the rancher's or herdsman's time and thus an automated solution is proposed. The system is designed to be as simple to use and as affordable to purchase as possible in an effort to make this invention a basic and viable tool of any rancher or herdsman with a medium-sized herd on up to the largest. Usually an automated herd counting tool is not cost effective for the rancher or herdsman with a small operation.

1.1 Motivation

Animals in India goes past the capacity of food creation. Productivity and Quality improvement depends on technology generation, technology transfer, technology users and support mechanisms, which need to be geared up. Farmers need to be updated on new technologies and scientific management practices of livestock production on regular basis. For the technology to be appropriate to the Australian livestock export industry three criteria appear to be essential. The industry's principal motivation for automation is not the Labour costs of tally clerks, estimated to be about 5\$ per sheep per count, but the lack of 100% accuracy inherent in human counting of large numbers of animals that superficially look alike. Of particular concern to industry is the discrepancy between the number of sheep counted when they leave Australia and when they arrive at their overseas destination. Exporters receive about \$80 for each sheep counted at its overseas destination, and hence lose this amount for every sheep that is delivered overseas but is not

counted by an overseas tally clerk. This loss is estimated to be about .3% of the sheep exported, suggesting that about 15,000 sheep are shipped each year that are not counted overseas. This amounts to an annual loss to the industry of about \$1,200,000. For an automated counting system to be adopted by industry it must be at least as accurate as, and preferably more accurate than, the manual system it replaces. Therefore, machine vision systems installed overseas that count pedestrians at a claimed accuracy rate of 90% or 95% are unsuitable for this application, even if they could be adapted to count sheep instead of people. Machine-vision systems designed to count pedestrians generally exploit this gap between heads to distinguish one person from another. We recommend how the mechanical system that we consider most likely to provide accurate and affordable livestock counting can be further developed, tested and trialed.

1.2 Existing System

Counting sheep would be trivially easy if each sheep were fitted with a device that uniquely identified it, and which could transmit the animal's identification number to a receiving station as the animal approached. Because of the advantages of individual animal identification for farm management, for tracing lost or stolen animals, and for tracing the origin of an animal when it finally arrives at an abattoir, governments round the world increasingly are requiring animal identification. Canada, for instance, is planning to implement a national identification scheme for sheep on 1 January 2002. (The Canadian national identification scheme for cattle, in which each animal is identified with a barcode ear tag, was implemented on 1 January 2001.) Many people in the Australian sheep industry believe that it is only a matter of time, perhaps five years, before all sheep in this country are individually identified by one or another method. Indeed, all sheep exported from Western Australia, and therefore the vast majority of sheep exported from Australia, now wear eartags. However, these tags, which cost about 20\$ each, are unsuitable for automated counting for the following two reasons. (1) It has been the exporters' experience that about 1% of ear tags fall off during the voyage from Australia overseas, so any counting system relying on the presence of ear tags at the overseas destination would not meet the industry's accuracy requirement. (2) Simple ear tags that identify an animal by means of printed numbers or a barcode cannot be automatically read. For a barcode reader to recognize the number of

a tag, the barcode has to be within line-of-sight of the reader. But if a sheep turns its head away from the reader or hides its head behind another sheep, this condition will not be met. And if someone is required to hold a sheep so that its ear tag is in a position to be scanned, that person may as well count the sheep directly, without bothering with the ear tag. Ear tags containing electronics that broadcast the animal's identification number when interrogated avoid problem (2), but still suffer from problem (1). Moreover, radio-frequency (RF) ear tags presently cost in excess of \$3 a piece, which makes them unaffordable unless they can be recycled and returned to Australia for use on subsequent sheep. A procedure involving overseas Labour (a) to remove RF ear tags after the sheep wearing them have been counted overseas and (b) to count manually the $\approx 1\%$ of sheep that have arrived without a working RF ear tag is conceivable, but we doubt that it would be the best solution to implement. Problem (1) of ear tags is avoided if, in place of an ear tag, each sheep swallowed a RF bolus that transmits the animal's identification number when interrogated. Studies in Canada have established that lambs weighing 20 kg or more are capable of swallowing and retaining such boluses for at least four months. The boluses are ultimately removed from the sheep's rumen at an abattoir. However, this technique also is unaffordable for the counting application, as a RF bolus presently costs about \$3.20, even in large-quantity orders. Researchers overseas are working on alternative RF animal identification technologies that may be available in the future at a lower price. However, we have found no indication that their research is likely to reduce the price from \$3 or more to 25¢ or less in the next few years.

Existing System Drawbacks: 1. Space is required to install system multiple systems required where sheep are to be counted at a port immediately prior to loading a ship. 2. Loss of ear tags on ships ($\approx 1\%$) is too high for ear tags to be the sole basis of automated counting. However, overseas Labour engaged to remove ear tags also could count sheep whose tags have fallen off on the journey. 3. Time and space would have to be allowed overseas for ear tag removal and for tallying sheep without tags. 4. Although sheep with intact tags could be automatically counted upon arrival overseas, reliance would have to be placed on overseas Labour to count the remaining sheep accurately.

2. METHODOLOGY

A deep learning-based convolutional neural network method is used for animal counting and detection in an image. DL is an emerging branch of supervised learning method in machine learning. For example, in neural network, for a given neuron function, the activation function is applied on the deep layers to extract the abstractions from voluminous data. This is similar to a hierarchical structure where deep learning models are applied. In the research domain, DL is a very promising and evolving area. DL has many highly developed algorithmic models such as convolution neural networks (CNNs), deep Boltzmann machines (DBMs), deep belief networks (DBNs), deep representation, recursive auto-encoders and restricted Boltzmann machines (RBMs). Generally, DL models are applied to the huge volume of unsupervised data generated by IoT devices, to automate the extraction from data. DL has combined with allied domains such as artificial intelligence, which simulate the human brain function to analyze, learn and extract the meaningful insights from the data gathered. The research works addressed towards this challenge, has been a key objective to develop DL algorithmic models.

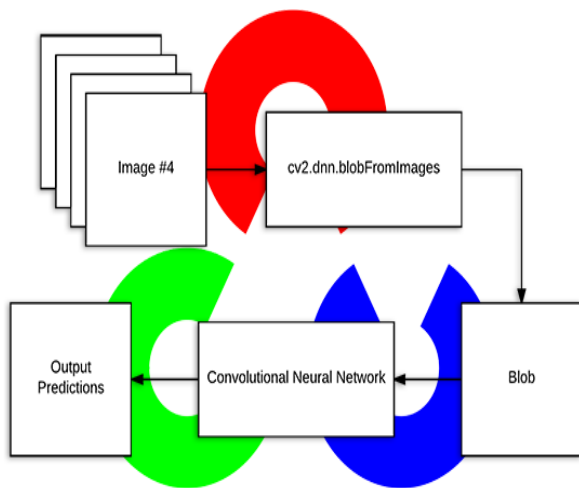

Fig 2.1-System architecture for animal counting and detection.

Image or video obtained from the camera. convert the videos to the frame. To obtain correct prediction from the DNN first we need to preprocess the data. Store image of each animal as a database which is used as a training set for our program, perform data augmentation (data augmentation is a technique that can be used to expand the size of training data). Frames are converted to grayscale for comparison. cv2.dnn.blob from image, is used to prepare input image for

classification it resizes the image to required resolution. We obtain the image through Blob which is our input image now. Blob is binary large object which is stored in binary data.

2. 1 Modules Description

A module depiction gives definite data about the module and its upheld parts, which is open in various habits. The Modules in this system are:

- Image Acquisition or Input Module.

In this module image is captured using a constant mega pixel camera. Further we will resize the image. Image resizing or image scaling is a geometric image transformation which modifies the image size. This picture scaling cycle can increment or lessening the goal of an objective picture with the goal that indisputably the size of picture information is balanced.

- Image Processing Module.

It is dependent on feature extraction method and input image type; the image is fed as input. Here Video is converted into frames and identify the livestock animal. We are building our model by using Convolutional neural network. We're going to have 3 convolution layers with max-pooling. Many a times, people first split their dataset into Train and Test. After this, they keep aside the Test set, and randomly choose X% of their Train dataset to be the actual Train set and the remaining (100-X)% to be the Validation set, where X is a fixed number(say 80%), the model is then iteratively trained and validated on these different sets. So, we will follow the same method to prepare data for training and testing phase. We are building our model by using Convolutional neural networks (CNN). CNN are a special architecture of artificial neural networks, proposed by Yann LeCun in 1988. CNN uses some features of the visual cortex. Now that we're done pre-processing, we can start implementing our neural network. We're going to have 3 convolution layers with 2 x 2 max-pooling. Max pooling: A technique used to reduce the dimensions of an image by taking the maximum pixel value of a grid. This also helps reduce over fitting and makes the model more generic. After that, we add 2 fully connected layers. Since the input of fully connected layers should be two dimensional, and the output of convolution layer is four dimensional, we need a flattening layer between them. At the very end of the fully connected layers is a SoftMax layer.

- Model training.

After Model development it is the ideal opportunity for model preparing. We were able to build a convolutional neural network that can recognize images. It is an initial set of data used to help a program understand how to apply algorithms to learn and produce sophisticated results

- Classification and output Module.

The image is classified using suitable machine learning algorithm and the particular type of animal is recognized and counting is shown.

2.2 Data flow Diagram

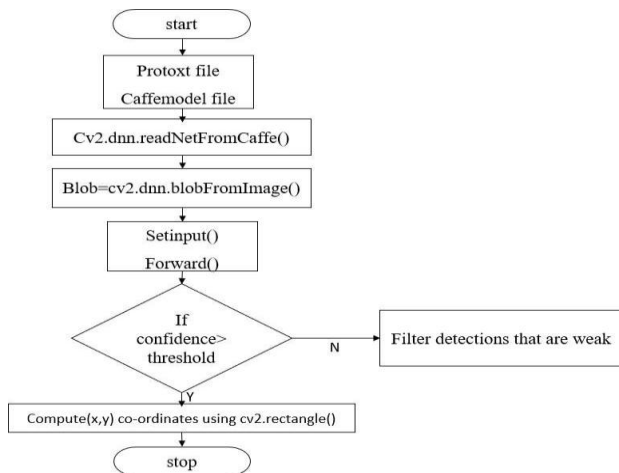

Figure 2.2: Flow chart for animal detection algorithm

Capturing phase:

To identify movement, we initially need to catch live pictures of the zone to be observed and held under reconnaissance. This is finished by utilizing camera.

Comparing phase:

Contrasting the current edges caught and passed edges to distinguish movement: for checking whether any movement is available in the live pictures, we think about the live pictures being furnished by the web cam with one another so we can identify changes in these casings and consequently foresee the event of some movement.

Pre-processing:

Pre - Processing Is heavily dependent on feature extraction method and input image type. Some common methods are:

- Denoising: applying a Gaussian or simple box

filterfor denoising.

- Contrast enhancement: ifgray levelimage is too dark or bright.
- Scaling by some factor.

2.3 Use case diagram

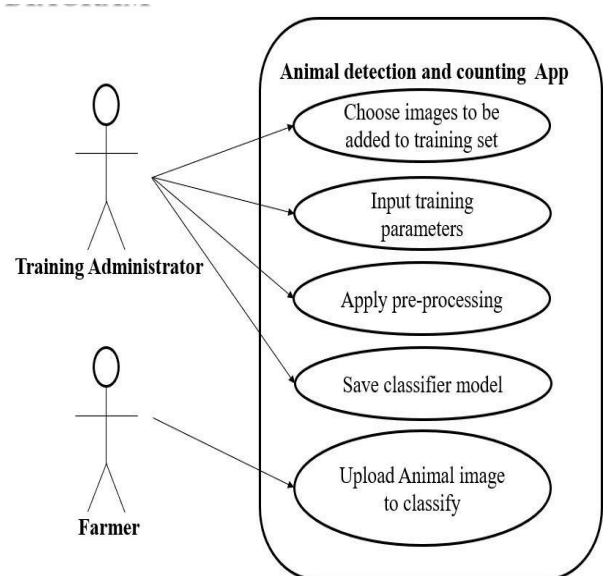

Figure 2.3: Use Case Diagram

Training Administrator

- The Training Administrator performs the operations that build the classifier model.
- He/she chooses the images that need to be added to the training set and the test set.
- He/she selects the proportion of dataset that need to be provided as training set and the test set.
- He/she inputs the different parameters on which the images have to be classified. i.e., provide the training parameters it means different characteristics of animal image is to be added to training set.
- He/she applies the pre-processing on the dataset of images to enhance the dataset.
- Finally, he/she saves the best classifier model generated into the server.

Farmer/User

- The farmer capture image or a video from the camera.
- He/she helps enhance the dataset by

uploading new images onto the dataset using augmentation.

2.4 Sequence diagram

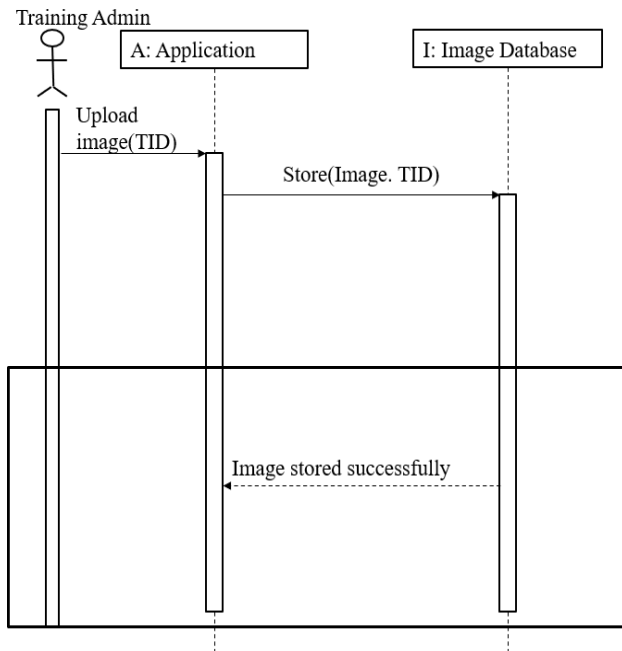

Figure 2.4: Sequence diagram for training the model.

The above figure shows the interactions between the Training administrator and the application and between the application and the database. Training admin will just upload the pictures of images to the application and that images stored in image database. Image database means training set, here labeling the data. Finally, it sends successfully stored message to the application.

3. IMPLEMENTATION

3.1 Working with OpenCV:

With OpenCV one can perform face detection using pre-trained deep learning face detection model which is shipped with the library.

- Prototxt file which defines model architecture.
- Caffe model file which contains the weights for the actual layer.
- The model is loaded into the net variable using `cv2.dnn.readNetfromcaffe()` function for reading a network model stored in caffe framework with arguments for "prototxt" and "model" file path.

- With `cv2.dnn.blobFromImage()` function we resize image.

3.2 Blob

- Blob stands for binary large object and is used to store information in the database.
- Blob is a data type that can store binary data.
- Whereas data types like arrays strings and similar data types are used to store normal data like integers characters, Blob can store multimedia files like images.
- With `cv2.dnn.blobFromImage()` function resizing the image to a required resolution can be done. 1.0 is scale factor and here we use default value so there is no scaling after that is spatial size that convolution neural network expects last values are mean subtraction value in tuple and they are RGB means and at the end function returns a "blob" which our input image after resizing , mean subtraction and normalizing.
- This requires more memory space compared to other data types.

3.3 Detection:

- With `setInput()` we are setting the new input image value for the network.
- Using `forward()` function we are running forward pass to compute output of the layer.
- Then the images are looped through the detections and secondary frames of varying height and width are drawn over the resized image for detection.
- We are extracting confidence and then comparing the confidence threshold.
- If the confidence is a minimum threshold, we proceed to draw secondary frames with the probability of detection.
- Then the images inside the frame are converted to grey scale for comparison.
- After the detection is confirmed the result is displayed along with the count.

3.4 Image Segmentation:

In the images research and application, images are often only interested in certain parts. These parts are often referred to as goals or foreground (as other parts of the background).

The image segmentation used in this is a threshold segmentation. To put it simply, the threshold of the grey scale image segmentation is to identify a range in the image of the compared with the threshold and accordingly to the results to the corresponding pixel is divided into two categories, the foreground and background.

Threshold segmentation has two main steps:

- Determine the threshold T
- Pixel value will be compared with the threshold value T.

In the above steps to determine the threshold value is the most critical step in partition. In the threshold selection, there is a best threshold based on different goals of image segmentation. If we can determine an appropriate threshold, we can correct the image for segmentation.

3.5 Algorithm

Input: Picture of animals.

Step 1: Image is converted to frame.

Step 2: Frame is converted to Grey Scale model.

Step 3: Augmentation is done to enhance the dataset available.

Step 4: The pictures are given to training using CNN model.

Step 5: The model is trained.

Step 6: The model is tested against the test data.

Step 7: Animals is classified using this model.

3.6 Hardware implementation

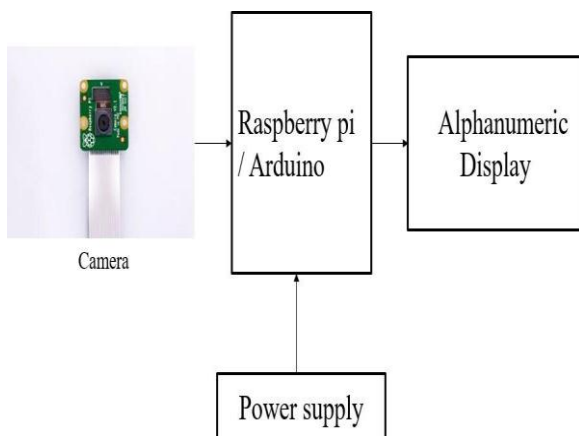

Figure 3.1: Interface design

This shows how user interact with the model and how components interact with each other. Camera is used to capture images or video, which is connected to

Raspberry pi and after processing result is displayed along with the count in Alphanumeric display.

3.7 Software implementation

The image that is sent by the camera is received by the PC for classification of animal. Database is created and the set of sample images are stored in it. The program consists of functions such as index Image, image Set and retrieve Image. The Image Set is used to hold a collection of images. Index Image is used to create an image search index. Index Image is used with the retrieved image function to search for images. The captured image is given as a query image to the processing system. The retrieve image function takes two arguments, a query image and the image stored in the database. The resultant is the indices corresponding to images index that are visually similar to the query image. The image ID's output contains the indices in ranked order, from the most to least similar match. The value match range is from 0-1. If the value is 0, then the image is not matched. If it is 1, then the query image is same as that of the stored image. If the value is between 0-1 then the query image falls under the category of the stored image i.e., the contents in the query images are same as that of the stored image. If the name of the image matches with that of the regular expression of the image then the animal is our livestock otherwise it is an intruder animal. If the score is in the range of 0.1 to 0.9, then the image is matched with that of the stored image.

4. RESULTS

4.1 Dissimilar Object Classification and Counting



Figure 4.1: Horse and Dog detection with count

4.2 Similar Object Classification and Counting



Figure 4.2: Sheep’s Detection with count

CONCLUSION

Deep Learning is a subset of machine learning comprising of various algorithms and was inspired by the human neural networks. The presented model was built on convolution neural networks for identifying the Livestock. This model is capable of extracting the features from the images by its various layers of CNN network model. We captured the image or video by using a camera and which is then converted to a grey scale image to make it feasible for comparison with the existing data set the CNN could effectively mine features from the images and a model was built for classification purpose. The system designed shown in the block diagram performs the detection and counting of the livestock. The raspberry pi is used to make the system portable and affordable by both small scale and large-scale livestock producers. The Flowchart shows the flow of operation done to detect the particular livestock and count them accordingly that is shown in result. Here first the image is captured by using a camera and which is then converted to a grey scale image to make it feasible for comparison with the existing data set values. The existing systems like bar code scanners and manually counting of livestock is not beneficial as it consumes a lot of time and the error margin becomes high so to overcome such hurdles, we have designed a real time system that performs such a task with efficiency, accuracy and is cost effective.

REFERENCES

- [1] R.Shanmugasundaram, S.Pavithra, V.Sangeetha, S.Tamilselvan, A.H.Thanveer Ahmed , –IoT based animal tracking and monitoring system in zoo||, South Asian Journal of Engineering and Technology Vol.3, No.2 (2017) 162–168.
- [2] Dr. P. Uma Maheshwari and Anjali Rose Ranjan, –Animal intrusion detection system using wireless sensor networks||, International Journal of Advanced Research in Biology Engineering Science and Technology (IJARBEST), Vol. 2, Special Issue 10, March 2016.
- [3] Pampapathi B S, Manjunath P C, –Intrusion Detection Using Passive Infrared Sensor (PIR) –, Asian Journal of Engineering and Technology Innovation, Volume 4, Issue 7.
- [4] So-Hyeon Kim, Do-Hyeon Kim, Hee-Dong Park, –Animal Situation Tracking Service Using RFID, GPS, and Sensors–, 2010 Second International Conference on Computer and Network Technology, 153 - 156, 2010.

BIOGRAPHIES



Darshan Raj

B.E Final year,
Department of Computer
Science and Engineering,
Bangalore Institute of Technology,
Bangaluru.



Prathik K

B.E Final year,
Department of Information
Science and Engineering,
Bangalore Institute of Technology,
Bangaluru.