

# “CFD Analysis of Square Microchannel Heat Exchanger”

Sagar Peshwani<sup>1</sup>, Prof. Navneetalal<sup>2</sup>

<sup>1</sup>M. Tech Scholar, Department of Chemical Engineering, Ujjain Engineering College, Ujjain (456010) – Madhya Pradesh

<sup>2</sup>Professor, Department of Chemical Engineering, Ujjain Engineering College, Ujjain (456010) – Madhya Pradesh

\*\*\*

**ABSTRACT:** This paper presents the numerical analysis of a 3D Square Microchannel Heat Exchanger in transient condition with hydrodynamically fully developed flow. The turbulence is increased with a helical twisted tape and is compared with the channel without twisted tape. The ANSYS FLUENT 15.1 code is used to solve the governing equations. An isothermal wall condition is maintained with Reynold number equals 100 and inlet velocity of 0.6m/s. The parameters like the heat transfer rate, axial wall shear stress, Nusselt number and heat transfer coefficient for both the types of channel are compared. It is found that the increase in turbulence occurs in channel with twisted tape arrangement and due to that the heat transfer characteristics like axial wall shear, skin friction; surface nusselt number and surface heat transfer coefficient are greater in with twisted tape as compared to that without twisted tape.

**(Key Words: ANSYS FLUENT, MICROCHANNEL, NUSSELT NUMBER, SKIN FRICTION, AXIAL WALL SHEAR)**

## 1. INTRODUCTION

Microchannel heat exchangers, or microstructured heat exchangers are heat exchangers in which (at least one) fluid flows in lateral confinements with typical dimensions below 1 mm. The most typical such confinement are microchannels, which are channels with a hydraulic diameter below 1 mm. Microchannel heat exchangers can be made from metal, ceramic. The concept of microchannel heat exchangers was proposed and used by Tuckerman & Pease in 1981. The first micro heat exchanger was developed by Swift in 1985.

### 1.1. Classification of Micochannel

It is a very debatable topic between the researchers to define a definition of microchannel. Mehendale et al. (2000) used a classification technique which is based on manufacturing to obtain various varieties of channel dimensions, where D is the smallest channel dimension.

$1 \mu\text{m} < D < 100$ : Microchannels

$100 \mu\text{m} < D < 1 \text{mm}$ : Minichannels

$1 \text{mm} < D < 6 \text{mm}$ : Compact Passages

$6 \text{mm} < D$ : Conventional Passages

Kandlikar and Grande (2003) adopted a different classification based on the rarefaction effect of gases in various ranges of channel dimensions, “D” being the smallest channel dimension:

$1 \mu\text{m} < D < 10 \mu\text{m}$ : transitional Microchannels

$10 \mu\text{m} < D < 200 \mu\text{m}$  : Micro channels

$200 \mu\text{m} < D < 3\text{mm}$ : Mini channels

$3\text{mm} < D$ : Conventional Passages

### 1.2 Twisted Tape:

The Twisted Tape is historically well known heat transfer enhancement mechanism. It offers moderate enhancement at relatively pressure increase for laminar, transition and turbulent flow. The stream line and velocity of flow field for a swirl flow induced by the twisted tape is higher than the plain tube. This phenomenon affects the heat transfer coefficient by increasing the turbulence higher tangential velocity near the walls.

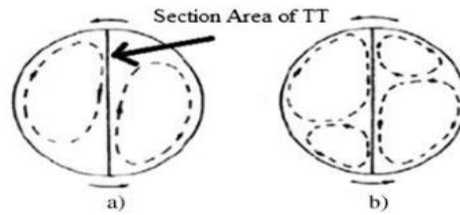

Figure 1.1 The secondary induced flow patterns by twisted tape

## 2. ANALYSIS

### Case 1

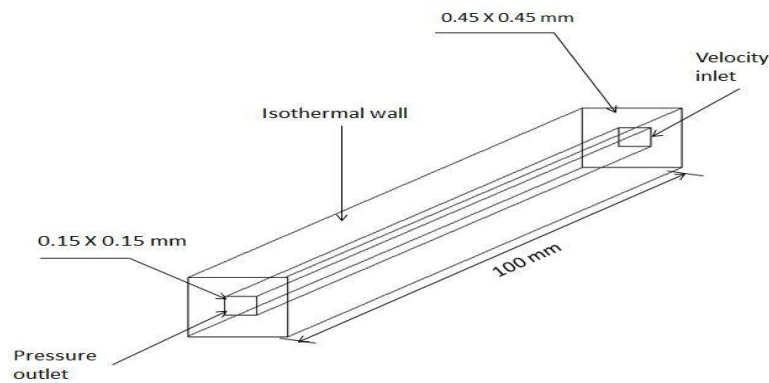

Figure 2.1- Square Microchannel without twisted tape

### Case 2

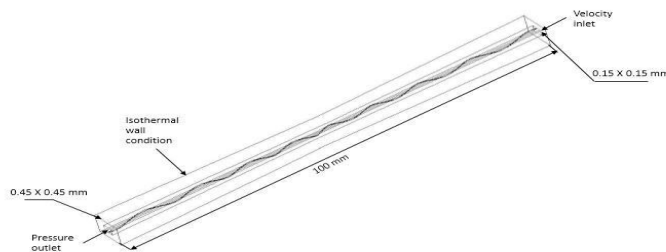

Figure 2.2- Square Micro channel with twisted tape

## 2.1 Assumptions

The physical and geometrical assumptions are following.

- (1) The flow is 3-D, laminar, incompressible and steady state.
- (2) Water is the working fluid.
- (3) Thermo-physical properties are taken constant.
- (4) There is no gravity effect.
- (5) Viscous dissipation is zero.

Based on the above assumptions, the governing equations are following

Governing Differential Equations

**Continuity equation**

$$\frac{\partial \rho}{\partial t} + \frac{\partial(\rho u)}{\partial x} + \frac{\partial(\rho v)}{\partial y} + \frac{\partial(\rho w)}{\partial z} = 0$$

Navier-stoke equation]

$$\rho \left( \frac{\partial u}{\partial t} + u \frac{\partial u}{\partial x} + v \frac{\partial u}{\partial y} + w \frac{\partial u}{\partial z} \right) = -\frac{\partial P}{\partial x} + \mu \left( \frac{\partial^2 u}{\partial x^2} + \frac{\partial^2 u}{\partial y^2} + \frac{\partial^2 u}{\partial z^2} \right) + F_x$$

$$\rho \left( \frac{\partial v}{\partial t} + u \frac{\partial v}{\partial x} + v \frac{\partial v}{\partial y} + w \frac{\partial v}{\partial z} \right) = -\frac{\partial P}{\partial y} + \mu \left( \frac{\partial^2 v}{\partial x^2} + \frac{\partial^2 v}{\partial y^2} + \frac{\partial^2 v}{\partial z^2} \right) + F_y$$

$$\rho \left( \frac{\partial w}{\partial t} + u \frac{\partial w}{\partial x} + v \frac{\partial w}{\partial y} + w \frac{\partial w}{\partial z} \right) = -\frac{\partial P}{\partial z} + \mu \left( \frac{\partial^2 w}{\partial x^2} + \frac{\partial^2 w}{\partial y^2} + \frac{\partial^2 w}{\partial z^2} \right) + F_z$$

Energy equation

$$\rho c_p \left( \frac{\partial T}{\partial t} + u \frac{\partial T}{\partial x} + v \frac{\partial T}{\partial y} + w \frac{\partial T}{\partial z} \right) = k \left( \frac{\partial^2 T}{\partial x^2} + \frac{\partial^2 T}{\partial y^2} + \frac{\partial^2 T}{\partial z^2} \right) + \Phi$$

Where  $\Phi$  is viscous dissipation factor

$$\Phi = 2\mu \left[ \left( \frac{\partial u}{\partial x} \right)^2 + \left( \frac{\partial v}{\partial y} \right)^2 + \left( \frac{\partial w}{\partial z} \right)^2 + \frac{1}{2} \left( \frac{\partial v}{\partial x} + \frac{\partial u}{\partial y} \right)^2 + \frac{1}{2} \left( \frac{\partial v}{\partial z} + \frac{\partial w}{\partial y} \right)^2 + \frac{1}{2} \left( \frac{\partial w}{\partial x} + \frac{\partial u}{\partial z} \right)^2 \right]$$

## 2.2 Boundary Conditions

Fluid media – Water

### 2.2.1 TEMPERATURE

Inlet temperature of water- 298K

Temperature of wall – 330K

### 2.2.2 VELOCITY

- The velocity at the inlet is 0.6 m/s which equals to a Reynolds number equal to 100.
- At the wall no slip boundary condition is considered.

### 3. NUMERICAL SOLUTION

The whole analysis is carried out with the help of software “ANSYS Fluent 15”. ANSYS Fluent 15 is computational fluid dynamics (CFD) software package to stimulate fluid flow problems. It uses the finite volume method to solve the governing equations for a fluid Geometry and grid generation. Pressure-based coupled algorithm is used to solve a coupled system of equations comprising the momentum equations and the pressure-based continuity equation.

### 4. RESULTS AND DISCUSSIONS

Results of different parameter and its discussion are done in this section.

#### 4.1 AXIAL WALL SHEAR STRESS

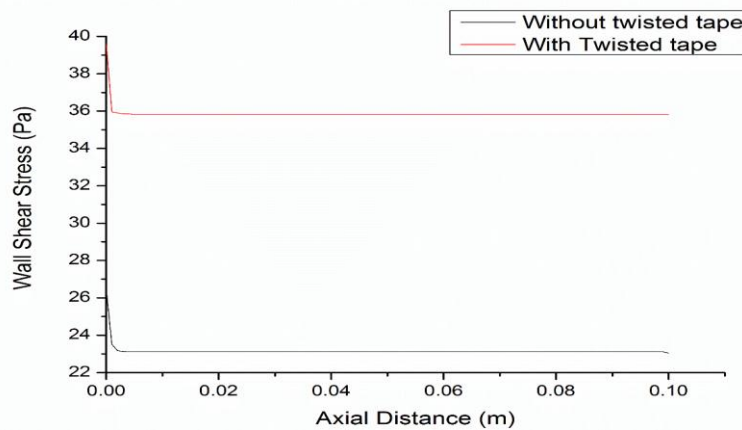

Figure 4.1 - Wall shear stress vs. axial distance

#### 4.2 Skin Friction Factor

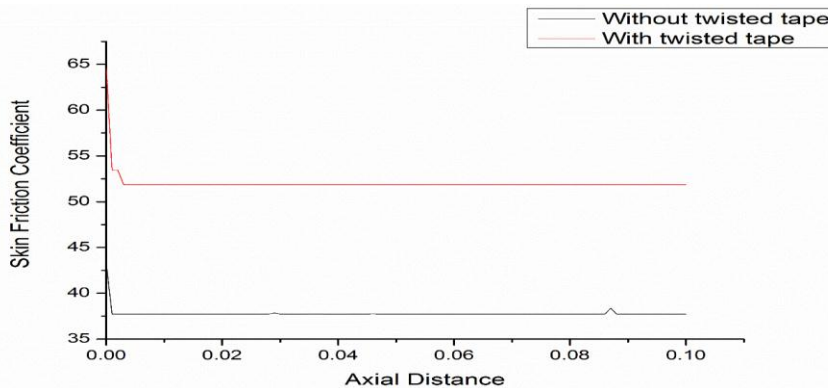

Figure 4.2- Skin fiction factor vs. axial distance

### 4.3 Surface Heat Transfer Coefficient

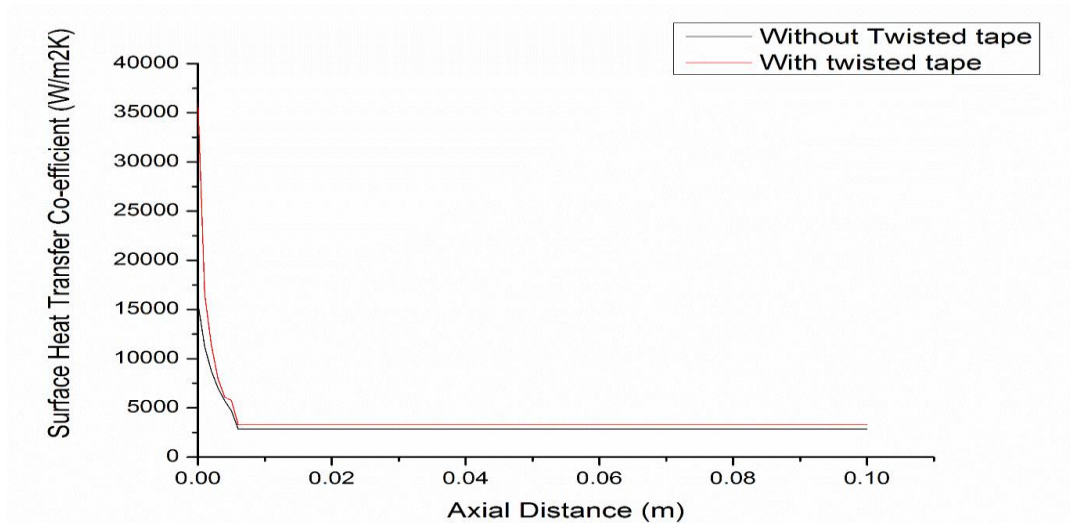

Figure 4.3 – Surface Heat Transfer Coefficient vs. axial distance

### 4.4 Surface Nusselt number

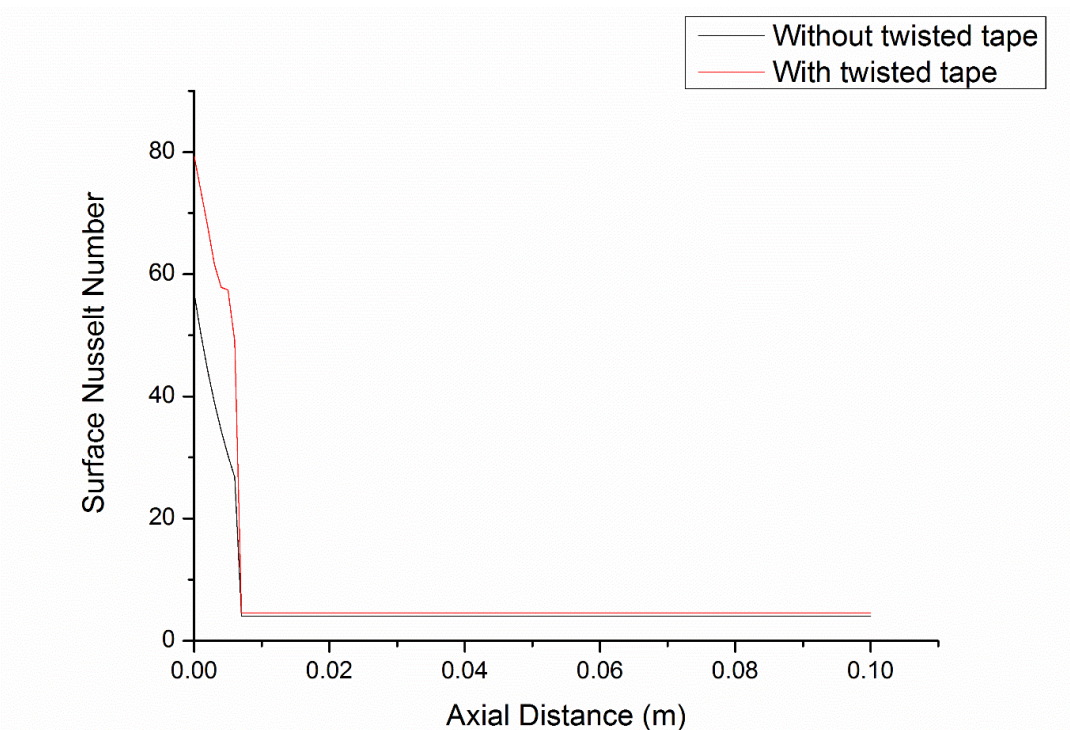

Figure 4.4 – Surface Nusselt Number vs. axial distance

## 5. CONCLUSIONS

In this paper heat transfer in the square micro channel heat exchanger with twisted tape and without twisted tape have been investigated by CFD FLUENT R15 code. From the present work following results are concluded

1. It is found that the axial wall shear stress increases when the twisted tape insert is employed with the conventional micro channel.
2. It can be concluded that the skin friction coefficient increases when the twisted tape insert is employed with the conventional micro channel.
3. From the above results it is found that surface nusselt number increases when the twisted tape insert is employed with the conventional microchannel.
4. Also Surface heat transfer coefficient increases when the twisted tape insert is employed with the conventional microchannel.
5. Due to twisted tape insert the increase in turbulence occurs which results in higher convective heat transfer.

## REFERENCES

- [1] D.B. Tuckerman, R.F. Pease, High performance heat sinking for VLSI, IEEE Electron. Dev. Lett. EDL 2 (1981) 126–129.
- [2] S.S. Mehendale, A.M. Jacobi, R.K. Ahah, Fluid flow and heat transfer at micro and meso-scales with application to heat exchanger design, Appl. Mech. Rev. 53(2000)175–193.
- [3] Errol B. Arkilic, Martin A. Schmidt & Kenneth S. Breuer, Slip flow in MicroChannels, Dynamics Symposium Oxford UK, July 1994.
- [4] S.Yu, T.A. Ameel, Slip-flow heat transfer in rectangular micro channels, Int. J. Heat Mass Transfer 44 (5) (2001) 4225-4234.
- [5] M. Gad-el-Hak, “The fluid mechanics of microdevices” – The Freeman Scholar Lecture, Trans. ASME, J. Fluids Engineering, 121, 5-33 (1999).