

# SMART TRAFFIC LIGHT CONTROL SYSTEM WITH AUTOMATIC VEHICLE SPEED BREAKER

Mr. V.S. Gadakh<sup>1</sup>, Avhad Vaishali<sup>2</sup>, Dherange Rutika<sup>3</sup>, Darade Sonali<sup>4</sup>, Shinde Pooja<sup>5</sup>

<sup>1</sup>Prof. Dept. of Electronics and Telecommunication Engineering, Amrutvahini Polytechnic, Sangamner, India

<sup>2,3,4,5</sup>Students, Dept. of Electronics and Telecommunication Engineering, Amrutvahini Polytechnic, Sangamner, India

\*\*\*

**Abstract** - The aim of the project is to design a smart traffic light control system interfaced with a barrier gate and a LDR based traffic light control system. When signal timing changes by delay is provided with the help of microcontroller, barrier on zebra crossing will open or close to allow vehicles to pass. When the signal is red the interfaced barrier gate closes and a buzzer notifies the closing of gate, thereby blocking the traffic but when the signal is green the same barrier opens and allows a proper flow of vehicles to avoid traffic jam. We provided time delay for all signal to change and buzzer action by using PIC microcontroller. In front of the barrier gate a stop line is drawn and with the help of another IR sensor, the vehicle is tracked whenever it crosses the stop line. PIC microcontroller is used for signal timing change as well as street light control according to LDR.

**Key Words:** Traffic Signals, Barrier Gate, DC Motor, PIC Controller, LDR, Buzzer.

## 1. INTRODUCTION

Generally we observe on the traffic signal, people violate the rule of traffic signal and create a disturbance and daze at signal point which create traffic, causes accident. To overcome this problem we provided a road blocker, which stop the vehicle on respective path depend upon traffic signal and stop the violation of traffic signal rule. To minimize or control the speed of vehicles we provided speed breaker from this speed breaker we generate electricity by using mechanism. This generated electricity we can use for operating the road blocker, this road blocker are operated on timing sensor. Also we provide the voice recognizing sensor for emergency situation such as ambulance, government class one vehicles etc. On road vehicles waste a tremendous amount of energy on speed breakers, where there is a necessity to provide speed breaker to control the speed of the vehicles. The annual rate of growth of motor vehicle population in India has been almost 20 percent during the last decade. There is tremendous vehicular growth in year by year. The increasing traffic and number of speed breakers on roads motivate to manufacture an innovative device which can channelize the energy of vehicles that is wasted on speed breakers to some useful work.

Vehicular traffic at intersecting streets is typically controlled by traffic control lights. The function of traffic lights requires sophisticated control and coordination to ensure that traffic moves as smoothly and safely as possible. Again for safety

purpose the way in which signal is being RED to mark the exact blocked through the signal as well as a series of rods with some height in the exchange of speed breaker and when GREEN opening the way to shut down the rods exchanging with speed breaker. Battery is used as a source and charging of battery through the mechanism provided, to make the action depending upon the movement of vehicle. Along with the Speed breaker, whereas the movement of up-down to rotate the shaft of alternator, battery get charge and it is available as a source to the system. In recent days electro-mechanical controllers are replaced by electronic circuits. The accuracy & fault tolerant drive towards electronic circuits. Also the provision of emergency calls like ambulance, fire brigade vehicles etc. By using sensor, along the way of emergency calls, traffic get blocked, availability is depending upon the priority call levels. This project is developed to meet the requirements of solid state traffic light controller by adopting microcontroller as the main controlling element, and LEDs as the indication of light. A microcontroller is interfaced to LEDs provide for centralized control of the traffic signals. Microcontroller is programmed in such a way to adjust their timing and phasing to meet changing traffic conditions. The circuit besides being reliable and compact is also cost effective.

### 1.1. LITERATURE REVIEW

[1] Vamsee Krishna Kiran M commented that when the user uses the Google maps, an android service begins in the background. The device collects speed breaker latitude and longitude data the proposed system is built in such a way that speed breakers don't need any person to tell. When a consumer encounters a speed breaker the sudden amplitude shift is noted.

[2] Shivam Gaikwad explains to develop Today's traffic safety solution requires all cars to slow down without realizing the speed of the ongoing vehicle, which raises the traffic issue. To prevent this, the device must work according to the speed of the car. In this assembly, the bumps of the smart speed breaker lower into the road surface is elevated above the physical residue.

[3] Dr. Raafiya Gulmeher addressed that Smart Speed Breaker system with IOT that will surface and only display if the speed of the vehicle is greater than those limits. Arduino board activates a motor to surface the speed breaker mechanism for control of the speed breaker, for use of RTC

in real time. The Arduino board sends a signal to the buzzer to start the beep sound to warn the driver according to the speed and distance of the breaker.

[4] Ajay S addressed that to have an automatic speed breaker on time demand according to the specifications the breaker disappears when there is no need for a speed breaker and when there is a need then the breaker comes on the road by spinning itself and begins to work slowing the vehicles speed. In implementing this definition, we use a hemisphere speed breaker made from iron

[5] M. Suresh discusses that the ambulance does not decrease the speed in order to save the patient from injury. As the ambulance approaches the speed breaker, the motor rotates after getting the signal. The speed breaker is flat. The speed breaker returns to normal after the speed programmed in the Arduino. The proximity sensor is located to avoid the rotation in the exact speed breaker location. The control circuit consists of Arduino, which processes the RF signal and transmits it to the RF receiver via the RF transmitter. The RF transmitter circuit shall be placed on the ambulance. The speed breaker lets the ambulance reduce speed, but this new flat speed breaker device plays a major role in protecting human lives by making the speed breaker flat.

**2. PROPOSED SYSTEM**

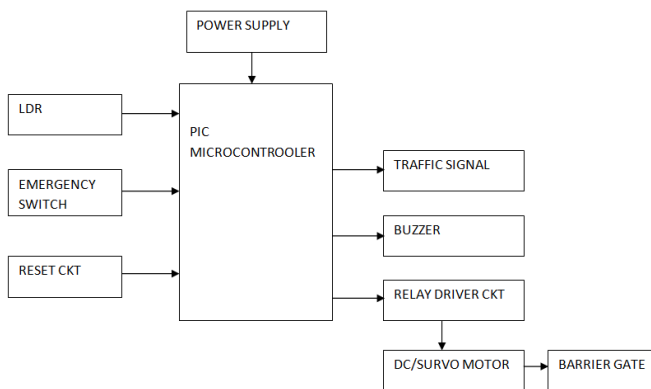

**Fig 1: Block Diagram of System**

In this project we are developing a new methodology in smart traffic light control system with automatic vehicle speed breaker. Here we are using barrier gate for automated speed breaker. Barrier gate connected to DC/Servo motor that motor control by relay driver. For smart traffic light control we are using LDR. When signal timing changes by delay is provided with the help of microcontroller, barrier on zebra crossing will open or close to allow vehicles to pass. When the signal is red the interfaced barrier gate closes and a buzzer notifies the closing of gate, thereby blocking the traffic but when the signal is green the same barrier opens.

**A. PIC 16f690 microcontroller:**

The PIC16F range of microcontrollers from Microchip are 8-bit MCUs that incorporate Microchip’s PIC® architecture into a variety of pin and package options, from space efficient 14-pin devices to feature-rich 64-pin devices. Devices with Baseline, Mid-Range or Enhanced Mid-Range architecture are available with numerous different peripheral combinations, giving designers flexibility and choice for their applications.

The PIC16F631/677/685/687/689/690 family of microcontrollers is based upon Microchip’s Mid-range core with an 8 level deep hardware stack and 35 instructions. These MCUs provide up to 5 MIPS, up to 7 Kbytes program memory, up to 256 bytes RAM and Data EEPROM of up to 256 bytes. On board is a configurable oscillator factory calibrated to ±1% accuracy.

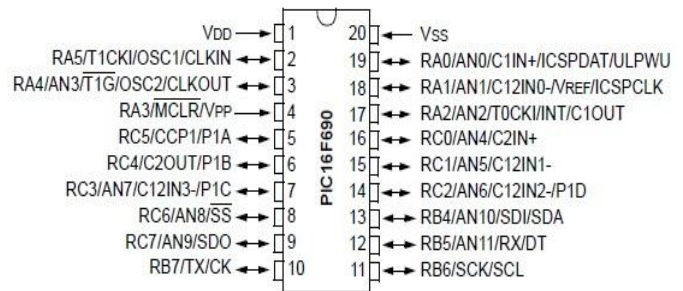

**Fig -2: pin diagram of PIC16f690**

**B. LDR:**

The working principle of an LDR is photo conductivity that is nothing but an optical phenomenon. When the light is absorbed by the material then the conductivity of the material reduces. When the light falls on the LDR, then the electrons in the valence band of the material are eager to the conduction band. Majority of street lights, outdoor lights, and a number of indoor home appliances are typically operated and maintained manually in many occasions. This is not only risky, however additionally it leads to wastage of power with the negligence of personnel or uncommon circumstances in controlling these electrical appliances ON and OFF.

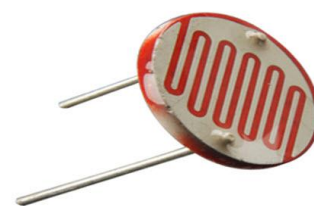

**Fig -3: LDR**

**C. BUZZER:**

A Buzzer is a device which makes buzzing or beeping noise. There are several kinds; the most basic is piezoelectric buzzer, which is just a flat piece of piezoelectric material with two electrodes. This type of buzzer requires some kind of oscillator to drive it. They are cheap and can be very loud without using very much power. Piezoelectric materials also produce a voltage in response to pressure, so piezo electric buzzer can also be used as crude pressure sensor or microphones. Typical use of buzzers and beepers include alarm devices, timers and confirmation of user input such as a mouse click or keystroke.



**Fig -4: BUZZER**

**D. DC MOTOR:**

The DC motor is a machine which transforms electric energy in the form of rotation into mechanical energy. The movement is brought about by the electromagnetism's physical behavior. Within DC motors have inductors which generate the movement-generating magnetic field. We used wiper motor here.

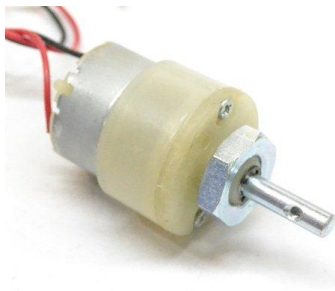

**Fig -5 DC MOTOR**

**E. RELAY:**

A relay is an electrically operated switch. Many relays use an electromagnet to operate a switching mechanism mechanically, but other operating principles are also used. Relays are used where it is necessary to control a circuit by a low-power signal (with complete electrical isolation between control and controlled circuits), or where several circuits must be controlled by one signal.



**Fig -6 Relay**

**F. LED Bulbs:**

The term LED means Light Emitting Diode, This LED bulbs are more efficient than the filament bulbs and tube lights. The Red, yellow and green bulbs are used in traffic signals to signify the stop, wait and go commands.



**Fig -7 LED Bulbs**

**3. CONCLUSIONS:**

The speed breaker allows the emergency vehicle to lower the pace, but this new flat speed breaker device plays the main role in safeguarding human lives by flattening the speed breaker. Transportation is easier and more convenient for emergency vehicle. This device will be introduced in future in most emergency situations, where emergency vehicles need to reach quickly with the help of solar energy.

**REFERENCES**

[1] Vamsee Krishna Kiran M,Vimalkumar k,Vinodhini RE,Archanaa R," An Early Detection Warning systems to Identify Speed Breakers and Bumpy Rods using Sensor in Smartphones", International Journal of Electrical and Computer Engineering, Vol 7 No.3,2017 June.

[2]Rajeshwari Madli,Santhosh Heber,Praveenraj Pattar,G.V.Prasad,"Automatic Detection and Notification of Potholes and Humps on Roads to Aid Drivers" ,IEEE Sensors Journal , 2016.

[3] Asma Farheen,Dr.Raafiya,"Automated speed breaker to Control Speed of Vehicle based on IOT", International Journal of Technical Innovation in Modern Engineering and science", Vol 5 issue 06,2019 June.

[4]Ajay s,Govind G,Dharmendhar S,parthasarathy J, "Automatic Speed Breaker on Time Demand Using Embedded Systems" , International Journal of Engineering and technology, Vol no 8, 2019 April.

[5]M.Suresh R.Jones Rexiya T,K.G.Santhosh R.Vignesh,"A Break Free Path for Ambulance using Speed Breaker", International Journal for scientific Research and Development, Vol 5,2017 June.

[6]TMahbuba Afrin, Md Redowan Mahmud, "Real time detection of speed breakers and warning system for on-road drivers", 2015 IEEE International WIE Conference on Electrical and Computer Engineering (WIECON-ECE)

[7]zer-Ming Jeng, Sheg Chung Tzeng, Bo-Jun Yang and Yi-Chun Li, "Design Manufacture and Performance Test of the Speed Breaker System" 2017 IEEE.

[8]Anchal Dewangan and Dr. N. K. Saikhedkar, "Experimental analysis of Different Types of Speed Breakers" 2018 IEEE.

[9]AravindKaruppaiah, Gansh.S, Dileepan.T, Jayabharathi.S, "Fabrication and Analysis of Automatic speed breakers" 2019 IEEE.[10]P. Mohamed Shameer and D. Christopher, "high Efficiency See Back Device for Power System Design and Efficiency Calculation: A Review of Potential Application" 2019 IEEE.