

# Design of Solar Operated Seed Sowing Machine

Sharvil Joglekar<sup>1</sup>, Akhilesh Desai<sup>2</sup>, Vedant Bhirud<sup>3</sup>

<sup>1,2,3</sup>B.E., Department Of Mechanical Engineering, A.P. Shah Institute Of Technology, Thane.

\*\*\*

**Abstract** - There is a need for improvement in agriculture sector, which can be achieved by using advanced technological methods for farming processes like digging, sowing and irrigation etc. Automation reduces labour cost and improves the overall productivity without affecting the quality of soil. The seed sowing machine is a key component of agricultural field. The various technique used in India for seed sowing and fertilizer placement are manual, ox and tractor operator. The manual and ox operator techniques are time consuming and productivity is low. Also, the fossil fuel used by the tractor causes emission to the atmosphere which is hazardous in some quantity. The main aim of this project is to create a green technology for seed sowing which will be easily operated over solar power by farmers and at low operating cost. Thus, solar operated automatic seed sowing machine will help the farmers of those remote areas of country where fuel is not available easily. Hence our prominent aim of this project Solar operated automatic seed sowing machine is to fulfil the tasks like digging, seed sowing, water pouring and fertilizing by using non-conventional energy sources. At the same time by using solar energy environment pollution can also be reduced. Thus, aiming to save the revenue of government & also most demanded fossil fuel.

**Key Words:** Seed, Automation, Solar power, DC Motor, Machine, Agriculture, Technology.

## 1. INTRODUCTION

For a long time, it has been thought that atomic energy would be a solution for the growing energy problem, but in recent times solar energy has proved to be an efficient, more secure and safe way of providing energy. Concepts related to the solar energy have constantly been under heavy research and development. The basic objective is to optimize the energy produced from photovoltaic cells, by making the overall systems more efficient and cost effective. Seed sowing machine is a device which helps in the sowing of seeds in a desired position hence assisting the farmers in saving time and money. The basic objective of sowing operation is to put the seed and fertilizer in rows at desired depth and seed to seed spacing, cover the seeds with soil and provide proper compaction over the seed. As the population of India continues to grow, the demand for produce grows as well. Hence, there is a greater need for multiple cropping on the farms and this in turn requires efficient and high-capacity machines. Mechanization of the Agricultural industry in India is still in a stage of infancy due to the lack of knowledge and the unavailability of advanced tools and machinery. Seed sowing machine saves time and labour

requirement, thus saving a lot of money along with the assurance of proper seed broadcasting. In addition, saving in cost of operation time, labour and energy are other advantages to be derived from use of improved machinery for such operations. A traditional method of seed sowing has many disadvantages. This project is about the different types of methods of seed sowing in the soil and developing a multifunctional seed sowing machine which can perform simultaneous operations in a single pass.

## 2. LITERATURE REVIEW

1. Kunal A. Dhande et.al in this work we replace complicated gear system by hall effect sensor for easier and costlier seed sowing and also reduce a need of labour. The Hall Effect sensor convert rotation into distance for which seed sowing at particular distance. Also, there is adjustable system for sowing at different distance. By using this machine, the sowing can be done row by row and distance will maintain.
2. Mahesh R. Pundkar stated that the seed sowing machine is a key component of agriculture field. high precision pneumatic planters have been developed for many varieties of crops, for a wide range of seed sizes, resulting to uniform seeds distribution along the travel path, in seed spacing.
3. Swetha S. et.al In this machine solar panel is used to capture solar energy and then it is converted into electrical energy which in turn is used to charge 12V battery, which then gives the necessary power to a shunt wound DC motor. This power is then transmitted to the DC motor to drive the wheels. And to further reduction of labour dependency, IR sensors are used to maneuver robot in the field.
4. Anuja Mohalkar et.al The conventional method is less efficient and time consuming. To meet the future food demand, the farmers have to implement the new technique which will not affect the soil texture but will increase the crop production. To overcome the drawbacks of conventional method we developing the seed sowing machine, this can perform different operations.
5. Mr. Ranjit et.al To meet the future food demands, the farmers have to implement the new techniques which will not affect the soil texture but will increase the overall crop production.

### 3. METHODOLOGY

1. In this machine a solar panel is used to consume solar energy and this energy is converted into electrical energy. The electrical energy is stored inside a 12V battery of capacity 7 Amp Hour, which then gives the necessary power to a DC motor. This power is then transmitted to the rear driven shaft through chain and sprocket system.
2. The whole machinery can work on solar power without the use of fossil fuel which cause pollution to the environment. The power will be transmitted to the driven shaft which will be controlled by a DC Motor speed controller operated by the desired speed farmer requires.
3. The soil digger tool is mounted on the chassis with an angle of 35 ° with respect to the ground. This was decided by comparing the actual plough tool used by farmers which has suitable angle varying between 15 ° to 50 ° depending upon the depth of cut.
4. Two hoppers are located on the either side of the vehicle from which the seeds are passed to a sowing mechanism.
5. The seeds coming from the hopper are picked up by a fan type arrangement which lifts the seeds from one side and then drops them on the other side of a u-shaped vessel. Then those seeds are dropped on the ground through a circular opening. This mechanism is connected to the driven shaft of the vehicle due to which it rotates simultaneously.
6. To put the soil back on the seeds a plate adjuster is used which cover the same previously digged soil back on the seeds. This was decided by taking into consideration the direction of flow of soil when it will be digged.

### 4. MATERIALS USED

Mild steel (Chassis), Rubber (Wheels), PVC Plastic (Hopper, Seed pipe, etc.), Cast Iron (Sprockets and shafts).

### 5. CALCULATIONS

1. A 12V 7Ah DC lead acid battery is taken which means it can continuously provide 7A current for one hour before getting completely discharged.
2. A 12V 42W DC motor is used thus,

$$P = (I) \times (V)$$

$$\therefore I = \frac{P}{V}$$

$$\therefore I = \frac{42}{12} = 3.5 \text{ A.}$$

3. The time for which motor can run before battery gets discharged will be,

$$Time (T) = \frac{Battery \text{ Ampere} - \text{hours}}{Motor \text{ Amperes}}$$

$$\therefore Time (T) = \frac{7}{3.5} = 2 \text{ hours.}$$

Hence the motor can run infinitely until there is solar supply. After that battery can back up the motor for approximately 2 hours.

4. A solar panel of 12V 100W is used thus I= 8.33A. Time required for panel to charge the battery,

$$Time (T) = \frac{Battery \text{ Ampere} - \text{hours}}{Panel \text{ Amperes}}$$

$$\therefore Time (T) = \frac{7}{8.33} = 50 \text{ minutes.}$$

5. Considering 40% losses for the chain drive and solar input,

$$\therefore Time (T) = \frac{1.4 \times 7}{5.5} = 70 \text{ minutes.}$$

6. Hence the battery will get charged in approximately 70 mins with constant solar supply. We can decrease the battery charging time by increasing the wattage of the solar panel to 150W or 200W.

### 6. PROJECT MODEL

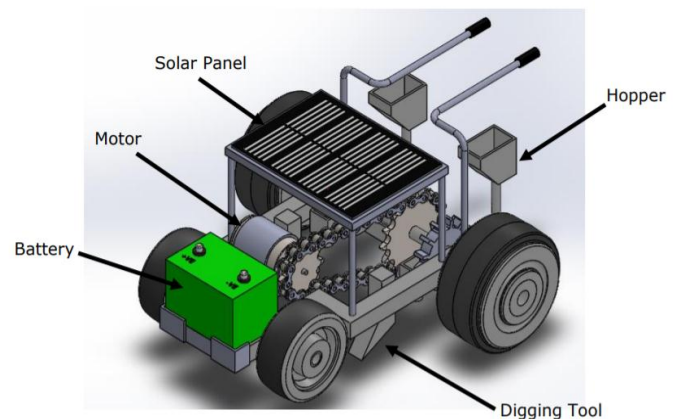

Fig 1. SEED SOWING MACHINE MODEL VIEW 1

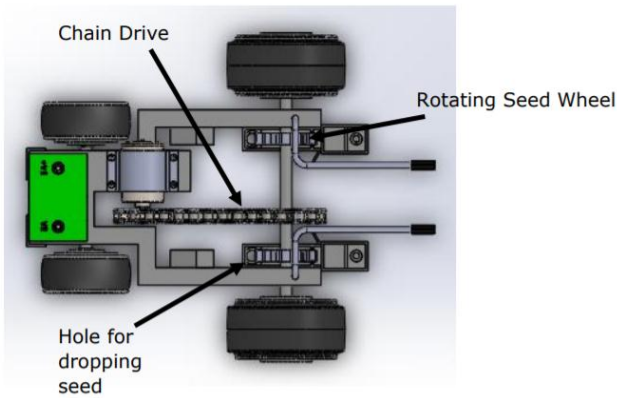

Fig 2. SEED SOWING MACHINE MODEL VIEW 2

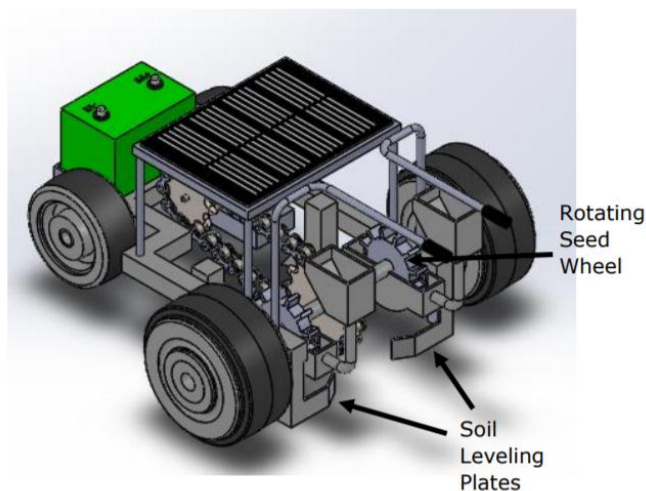

Fig 3. SEED SOWING MACHINE MODEL VIEW 3

Approximate dimensions for the complete assembly are 700mm x 450mm x 350 mm. The drive gear consists of 10 teeth whereas driven gear consists of 15 teeth which results in a gear ratio of 1.5. The driven gear teeth are more than the drive gear teeth hence, more torque is produced reducing speed a little. This is done due to the abrupt soil conditions due to which a good torque is needed to turn the wheels.

### 7. APPROXIMATE COSTING

1. 12V 7Ah DC Lead Acid Battery – INR 700-800.
2. 12V 42W DC Motor – INR 300-500.
3. 12V 100W Solar Panel – INR 3000-5000.
4. DC Motor speed controller – INR 200-300.
5. Miscellaneous – INR 500-1000.

### 8. FUTURE SCOPE

1. Using remote control, the machine can be made fully automatic.
2. Multi hoppers can be used for sowing large farms.
3. Seed spacing sensors can be used for accurate spacing.
4. Water sprinkling system can be added to it.

### 9. CONCLUSION

This is a semi-automatic machine which is equipped with a four-wheel drive. The seed sowing machine is developed at a very low cost. It is cheap and easily affordable by rural farmers. It is maintenance free and various adjustments can be made with ease for continuous operation.

The recommended row to row spacing, seed rate, seed to seed spacing and depth of seed placement can vary from crop to crop and for different agroclimatic conditions to achieve optimum yields.

### REFERENCES

- [1] Chilgar, S. S., & Chilgar, S. S. (2008). Design and Fabrication of Multipurpose Solar Operated Seed Sowing Machine. International Research Journal of Engineering and Technology, 5500. www.irjet.net
- [2] Swapnil, Thorat & Kasturi, Madhu & Girish, Patil & Rajkumar, Patil. (2018). Design and Fabrication of Seed Sowing Machine. 10.13140/RG.2.2.12391.75684. R. Nicole, "Title of paper with only first word capitalized," J. Name Stand. Abbrev., in press.
- [3] Kolgiri, Somnath. (2016). "SOLAR SEED SOWING MACHINE".
- [4] Singhal, Kalash & Prajapati, Gaurav & Saxena, Vipul. (2018). Solar Powered Seed Sowing Machine. 259-262.
- [5] Suresh, D.S., Prakash, K.V., Rajendra. C.J. (2013). Automated Soil Testing Device", ITSI Transactions on Electrical and Electronics Engineering (ITSI-TEEE) ISSN (PRINT): 2320 – 8945, Vol. - 1, Issue -5, 2013.
- [6] Prof. Pranil V. Sawalakhe , Amit Wandhare, Ashish Sontakke and Bhushan Patil, "Solar Powered Seed Sowing Machine", Global Journals of Advanced Research in Mechanical Engineering, Vol-2, Issue-4, PP.712-717, 2015.
- [7] Swetha S. and Shreeharsha G.H, "Solar Operated Seed Sowing Machine", International Journal of Advanced Agriculture Sciences and Technology 2015, Volume 4, Issue 1, PP.67-71, 2015.