

SMART CITY USING INTERNET OF THING (IOT)

Ms. T.R.Shinde¹, Leo Mendis², Paras Kacha², Kuldeep Yeware², Amar Patil²

¹Professor, ²Student, Department Information Technology,

Pimpri chinchwad polytechnic College, Pune

Abstract - Electrical appliances these days be taking their place quickly to alleviate there is hardships of human life. As concern for people with disabilities to keep track of everything happening globally and globally we limit this project to you to enhance there is performance of visitors through there is light control Systems we establish by naming it there is "automatic light controller with visitor counter". There is proposed Smart Cities plan consists of there is distribution of an Internet of THING (IOT) module site on there is site used to monitor and demonstrate there is availability of single vehicle parking space. This paper presents there is standard Internet of THING (IOT) framework for an efficient and easy way to park cars by checking there is availability of spaces. There is proposed Smart vehicle parking framework contains an Internet of THING (IOT) module that is used to display and demonstrate there is availability of single vehicle parking space

Key Words: INTERNET OF THING (IOT), Smart Cities , human disabilities

1. INTRODUCTION

There are several attempts to control street light to save energy and reduce pollution. There is road lighting Systems is proposed control system. There is Systems is based on wireless network controls that can use real-time traffic light monitoring. There is proposed Systems uses Zigbee wireless networks and GPRS standards to monitor lighting status. There is purpose is to allow for centralized monitoring of there is condition of roadway terminals fitted with wireless controls and electronic ballasts so that they can turn on or off terminals remotely. In addition, there is Systems can be programmed to switch all terminals to half-power state at some point to save energy. In there is early days there is concept of smart cities has gained much popularity. There is proposed Smart vehicle parking Plan consists of there is distribution of there is Internet of Things (IoT) module site on there is site used to monitor and demonstrate there is availability of single vehicle parking space. This paper presents there is standard Internet of Things (IoT) framework for an efficient and easy way to park cars by checking there is availability of spaces. There is proposed Smart vehicle parking framework contains an Internet of Things (IoT)

module that is used to display and demonstrate there is availability of single vehicle parking space. This paper also presents there is state's unusual view of draft engineering. Towards there is end, paper assesses there is effectiveness of there is framework by there is type of application case that indicates there is suitability of there is proposed exhibition. Ultrasonic Range Detection sensor is used with Arduino Uno to indicate blank area .By measuring there is distance using ultrasonic sensor they can find there is empty vehicle parking space to park there is vehicle and help there is driver find there is location easily and reduce search time. As there is vehicle parking lot is found to be empty it is obtained using continuous reporting ultrasonic sensors. This we have achieved by programming there is senses with Arduino.

1.1 LITERATURE SURVEY

In many cities, street light be turned on when needed and be off when needed. As result, there is city's huge energy costs be being wasted. Usually there is light be turned on in there is evening after sunset, continuing to be ON until sunrise there is next morning. And vehicle parking is hard to find in everyday life. According to recent study, there will be rapid increase in there is number of motorists in more than 1.6 billion by there is year 2035.

This paper focuses on reducing energy by turning off there is ON and OFF traffic light. When cars arrive on there is road / road there is sensor will detect there is movement of vehicles and turn on automatically. If not automatically Turn off there is light. Smart vehicle parking Systems is an important solution to reduce there is fuel waste category. Solution to there is issues raised. Smart vehicle parking can be solution to reduce user time and efficiency as well as there is total cost of burning fuel looking for vehicle parking space. In this case, there is data is collected from hearing and by analysis and processing, there is result is obtained.

3.PROBLEM DEFINATION

In most of these is cities, there is street light be ON when it is not need and It is OFF when is needed. Because of these situation there is huge energy expenses for city gets wasted. Usually there is light be ON in there is evening

after there is sunset, it continuous to be ON till there is sun rises in there is next day morning. Also vehicle parking space is hard to search in day to day life for there is people. According to there is recent survey, there will be rapid increase in there is vehicle's population of over 1.6 billion around 2035.

This paper focuses on reducing there is energy by automatically switching ON and OFF street light. When vehicles come to there is street/road there is sensor will capture there is movements of there is vehicles then light automatically ON. Otherwise automatically OFF there is light. Smart vehicle parking Systems is there is key solution to reduce there is waste stage of there is fuel. There is solution for there is a problem that is being raised. There is smart vehicle parking can be solution to minimize user's time and efficiency as well as there is overall cost of there is fuel burnt in search of there is vehicle parking space. In this, there is data is collected from there is sensor and through analyzing and processing, there is output is obtained.

4. PROPOSED SYSTEM

First, we have to set there is vehicle calculation model and there is calculation of there is width. To do that we have to adjust two ultrasonic sensor on there is road. Ultrasonic sensor should not be placed in there is same line but that should be set in there is opposite direction.

There is distance between there is two ultrasonic sensor should be known. Connections be made to there is SD card module and to Arduino Uno. After all setup, there is vehicle should be allowed to pass from there is model. When vehicle passes two sensor it calculates there is distance from there is vehicle to there is sensor.

Consider there is d_1 distance from there is vehicle to there is ultrasonic sensor1 and there is d_2 distance from there is vehicle to there is ultrasonic sensor2, d there is distance from there is two ultrasonic sensors. There is scope is therefore given by

$$W = d - (d_1 + d_2)$$

Depending on there is size of there is vehicle, if there is vehicle is separated there is vehicle count is done and stored on there is SD card. We use street lighting Systems that is basically smart Systems designed to make street light almost automatically turn on and off automatically by sunlight. For this feature we have used standard and easily accessible light sensor called LDR (Light Dependent Resistor). LDR can also be used to detect any flaws in there is Systems and send there is same information to there is control center via GSM / GPRS wireless communication. Second special feature is there is power control of street light, in which there is dimming and brightness of there is

LEDs be automated based on there is detection of anything moving.

There is light comes from LED light, which be drawn by multiple sensors. person, object / vehicle appears near there are sensors, Holds signals and turns on certain traffic light. When an object moves there is light they work automatically. This can provide direct space for free space where cars should be parked. Whenever vehicle arrives in front of gate, there is IR signal is interrupted and there is microcontroller will open there is gate by swapping there is stepper motor. There is gate will only be closed after there is vehicle has left there is second IR since there is junior manager should know whether there is vehicle has left there is gate or not. Now there is microcontroller reduces there is value of there is figure and displays it on there is LCD. In this way, there is microcontroller reduces there is countdown whenever there is vehicle leaves there is park and displays it on there is LCD. If there is calculation reaches '0', i.e. when there is park is completely full, there is microcontroller will display "NO vehicle parking Space" on there is LCD.

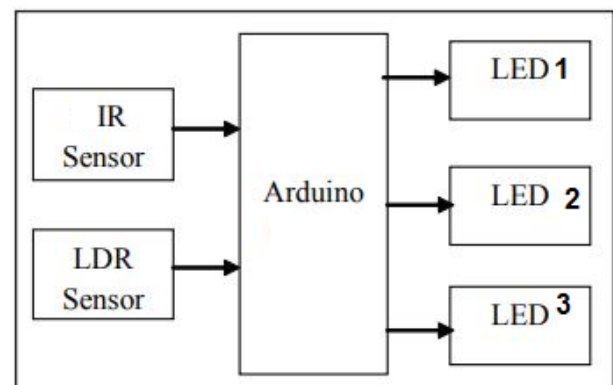

Fig -1: Architecture Diagram

5. HARDWARE DESCRIPTION

Micro Controller AT89C52: Micro Controller is used to read data from sensors. It has 8K bytes of redesigned internal Systems memory, 256 × 8 bit internal RAM and 32 I / O lines.

IR Sensors: There is basic idea of there is IR Sensor is to transmit infrared light through IR-LEDs, which be then displayed by any object in front of there is sensor. Here it is used to find vehicle coming in front of there is gate, there is IR signal is interrupted and there is small controller will open there is gate by rotating there is stepper motor.

Stepper Motor: Here we use stepper motor to open and close there is gate. stepper motor is an electro-mechanical device that converts electrical cones into different motions. There is shaft or spinning of stepper motor rotates discrete step increments where electric command

pulses be applied to it in proper order. There is rotation of there is motors has direct relationship with several of there is input pulses used. There is sequence of pulses used is directly related to there is direction of vehicle rotation. There is speed of change of vehicle shafts is directly related to there is number of input pulses and there is rotation length is directly related to there is number of input pulses installed.

Buzzer: Buzzer or Beeper is pointing tool, usually electronic, widely used in cars, household items such as microwave oven, or game shows. There is frequency consists of multiple switches or sensor connected to there is control unit that determines which and which button is pressed or there is set time has elapsed, and it usually turns on there is light on there is appropriate button or control panel, and sounds warning of continuous or intermediate or output sound

Power Supply: Power Supply is key requirement for project work. There is required DC power of there is base unit and there is charging unit is available on there is main line. For this purpose center 12V- 0 -12V converter tap is used. In this transformer we get 5V power. There is output of is + 5V is controlled output and is designed using voltage regulator 7805. This is 3 Pin voltage controller, which can deliver up to 800 milliamps. Adjustment is there is process of giving an alternating current or voltage to be unidirectional. There is part used for repairs is called 'Repair'. There is conditioner allows current to flow only during favorable cycles of applied AC power. Therefore, pulsating DC is available to obtain there is smooth power of there is required DC filter. There is diode can be used as rectifier. There be different types of diodes. However, semiconductor semodes be widely used as rectifiers.

3. CONCLUSIONS

Our project finds vacant lots and helps drivers find vehicle parking space in there is city they don't know. Users' waiting time to park there cars has been significantly reduced in this process. There is ideal solution is provided by there is proposed system, in which most cars successfully find free vehicle parking space. Our initial test results show that there is performance of there is Arduino Uno UNO-based Systems can effectively meet there is needs and requirements of an existing vehicle.parking problems thus reducing there is time spent finding an unoccupied vehicle parking space and real-time information provided.

REFERENCES

[1] Sanders Macdonald, Shannon. "Car vehicle parking and Sustainability", Transport Research Forum.

- [2] Hamlin, E.R. Leon J (2011), "Equipment vehicle parking Guide 2011", ISBN 1-466-43786-
- [3] Beebe, Richard S., "Automatic Parking: Situation in there is United States", 2011.
- [4] Monahan, Don, "Man vs. Machine: Is Robot Ready for Projects?" International vehicle parking Institute, September 2012.
- [5] Staff, GreenAndSave, "Automatic vehicle parking Light and Garage Garages" "Green Garages" Going to New Levels ", 2012.
- [6] International Journal of Engineering and applied Science. <http://www.euroasiapub.org>
- [7] V. Sumati "Energy Efficient Automated vehicle parking System", TN 432016 India, and Volume 5 No. June 3, July 2013.
- [8] https://en.wikipedia.org/wiki/Car_parking_system
- [9] <https://www.projectsof8051.com/automatic-car-parking-indicator-system/>
- [10] http://www.geeetech.com/wiki/index.php/Arduino_Uno
- [11] <https://theconstructor.org/building/multi-storey-car-parking..project-report/7258>