

Design of DVR using SVPWM, Fuzzy and PI controller

Mrs. Varsha Shikhare¹, Mrs. Yogini Bhosale²

¹P.G. Student, Dept. of Electrical Engineering, RIT collage, Maharashtra, India

²Professor, Dept. of Electrical Engineering, RIT collage, Maharashtra, India

Abstract - The power quality is one of the major problems in power system environment. Some situations like voltage sag or swell, harmonic content and so on and its major effect on load side. To face these problems custom power devices are utilized. Sensitive loads have to serve impact on itself due to voltage sag and swell. The dynamic voltage restorer (DVR) is a power custom device used in power distribution network. This device has much quality like fast flexible and efficient solution to voltage sag problem. The principle of DVR is utilized to inject the voltage in series and synchronism with standard voltage. The important parts of DVR are voltage source inverter (VSI), boost transformer, filter and DC energy source. This device has great performance in protecting the critical load from voltage sag and swell problems. So, I am preferring this device for my design work to protect the critical loads. By using DVR, I will compensate the voltage fluctuation problem in the power distribution network.

Key Words: (DVR) Dynamic Voltage restorer, (VSI) Voltage Source Inverter, Sag, Swell, Harmonic

1. INTRODUCTION

The power distribution network should provide their customers with an uninterruptable power flow of energy with smooth sinusoidal voltage. The distribution system has number of nonlinear loads which affects the quality of power supply. As a result of nonlinear loads, the purity of waveforms of supply is lost. Part from nonlinear load capacitor switching, motor starting and unusual faults causes power quality problems. The power quality problem is defined as deviation of voltage and current from its ideal waveform. Faults at either transmission or distribution may cause voltage sag or swell in the entire system. Voltage sag and swell cause sensitive equipment to fail and create large current unbalance. This effect cause equipment damage.

There are many different methods to mitigate voltage sag and swell problems but use of custom power device is very efficient method. The term custom power means use of power electronics controller in distribution system. Custom power assures the customer to get pre-satisfied quality and reliability of supply. There are different types of custom power devices available to improve power

quality problems. But compared to the other devices' DVR is best economic solution for this problem.

To get higher output voltage from three phase inverter there is need to reduce switching losses of inverter. This is achieved by selecting proper switching sequence pattern for the inverter. To fulfill this requirement PWM technique have been developed. There are number of modulation techniques from which space vector PWM is very popular. There are different control methods for controlling the DVR among all the methods the SVPWM i.e. Space Vector Pulse Width Modulation is very effective

1.1 PROBLEM STATEMENT AND PROBLEM DEFINATION

The power quality issues are big problems for sensitive load. To protect the load there is need to use power custom devices. From different types of power custom devices, the DVR is most efficient and reasonable option. But the inverter of DVR has switching losses and harmonic distortion which affects the total output voltage of DVR. There is need to reduce the switching losses and total harmonic distortion of inverter. As shown in following equation we have to reduce the value of total harmonic distortion (THD).

$$THD_F = \frac{\sqrt{V_2^2 + V_3^2 + V_4^2 + \dots}}{V_1}$$

2. Dynamic Voltage Restorer

The DVR is a mostly used power custom device. The main function of DVR is reducing the voltage sag problem and protect the sensitive loads. They have been designed to compensate the voltage sag 35% for duration of time less than half a second. A DVR is connected in series with feeder using an injection or coupling transformer. The objective of DVR is mainly to regulate voltage at load bus, it remains most of the time in standby mode during which the converter is bypassed. Only when the voltage sag is detected, the DVR injects a series voltage of required magnitude. A DVR with power electronics device can be controlled to act as a series active filter to isolate the load from voltage harmonics on source side. It is also possible to balance the voltage on the load side by injection negative or zero sequence voltage in addition to harmonic voltage. The schematic representation of DVR is shown in following fig. (1).

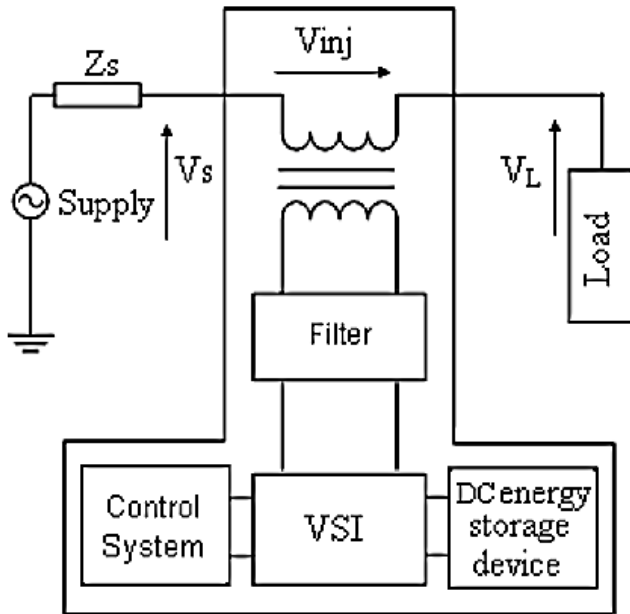

Fig.1 Schematic Representation of DVR

3. Control Technique

There are many types of control techniques for inverter switches among which the space vector pulse width modulation i.e. SVPWM is widely used. The SVPWM is gives very superior output than any other technique. It provides special switching for three upper power switches of three phase inverter. It also utilizes supply voltage more efficiently. In this method the magnitude of frequency of reference voltage vector is used to control the magnitude and frequency of fundamental voltage.

In this method the three phase quantities Va, Vb, Vc in abc coordinate system can be transformed into α-β coordinate system using the following equation,

$$\begin{bmatrix} V_\alpha \\ V_\beta \end{bmatrix} = \sqrt{\frac{2}{3}} \begin{bmatrix} 1 & -1/2 & -1/2 \\ 0 & \sqrt{3}/2 & -\sqrt{3}/2 \end{bmatrix} \begin{bmatrix} V_a \\ V_b \\ V_c \end{bmatrix}$$

Two axis stationary to two axis rotating frame transformations are obtained by using following equations,

$$\begin{bmatrix} V_d \\ V_q \end{bmatrix} = \begin{bmatrix} \cos\theta & \sin\theta \\ -\sin\theta & \cos\theta \end{bmatrix} \begin{bmatrix} V_\alpha \\ V_\beta \end{bmatrix}$$

So, we get the values of Vref and α as per following equations,

$$V_{ref} = \sqrt{V_d^2 + V_q^2}$$

$$\alpha = \tan^{-1}\left(\frac{V_q}{V_d}\right)$$

4. Fuzzy Logic Controller

In fuzzy logic, basic control is determined by aet of linguistic rules which are determined by the system. Since numerical variables are converted into linguistic variables, mathematical modeling of system is not required. The fuzzy logic controller is proposed for controlling the inverter action. It has two real time inputs measured at every sample time, named as error and error rate and one output named actuating signal for each phase. The input signal is fuzzified and represented in fuzzy set notations as membership functions. The defined rules produce output signal and these signals are de-fuzzified in analog control signals for comparing with carrier signal to control PWM inverter. The following fig. (2) shows the block diagram of fuzzy logic controller.

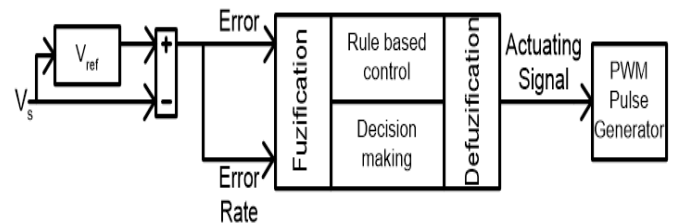

Fig.2 Block diagram of proposed control system

5. Simulink Model of DVR with SVPWM and THD Analysis

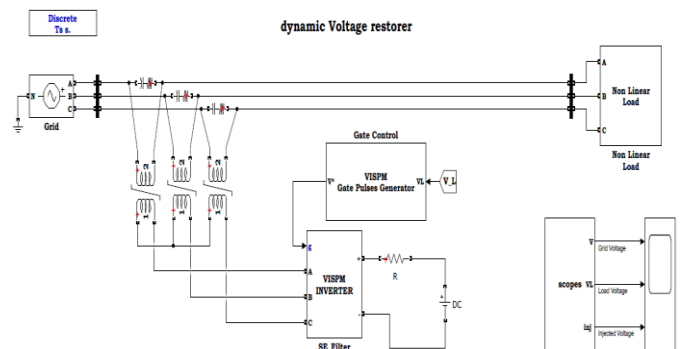

Fig.3 Simulink Model of DVR with SVPWM

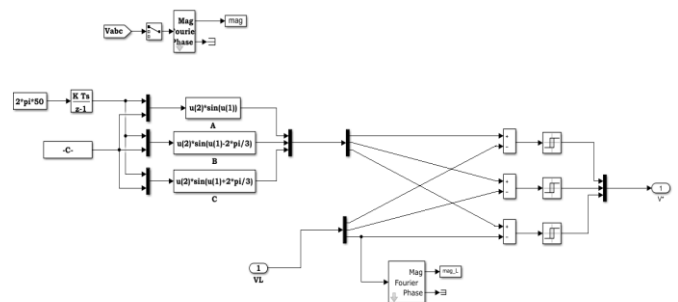

Fig.4 Gate Control using SVPWM Technique

The Simulink model for SVPWM is shown in fig.3. and the gate control of inverter switches is shown in fig.4. The three-phase sinusoidal voltage is converted into two phase system using Clark's transformation. Then two-phase equivalent is transformed into polar. From this get the two output first is magnitude of reference and second is angle of reference. For a given magnitude and position and vref can be synthesized using three nearest stationary vectors based on the switching states so the gate signals for active switches can be generated. when vref passes through the sectors various sets of switches will be turned on or off. as a result, when vref rotates one revolution, the inverter output voltage completes one cycle. Thus, the output of inverter block is phase voltages. The total harmonics distortion of simulated is shown in following fig.

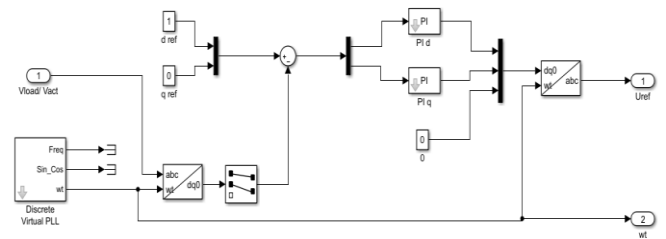

Fig.7 Subsystem of DVR with PI controller

The main function of PI controller is utilizing the error signals from comparator to trigger inverter switches. The above fig.3 shows MATLAB Simulink model of PI controller for DVR. The result of this model is shown in following figures which will be used for comparison with fuzzy logic controller-based DVR.

7. THD Analysis of PI Controller Based DVR

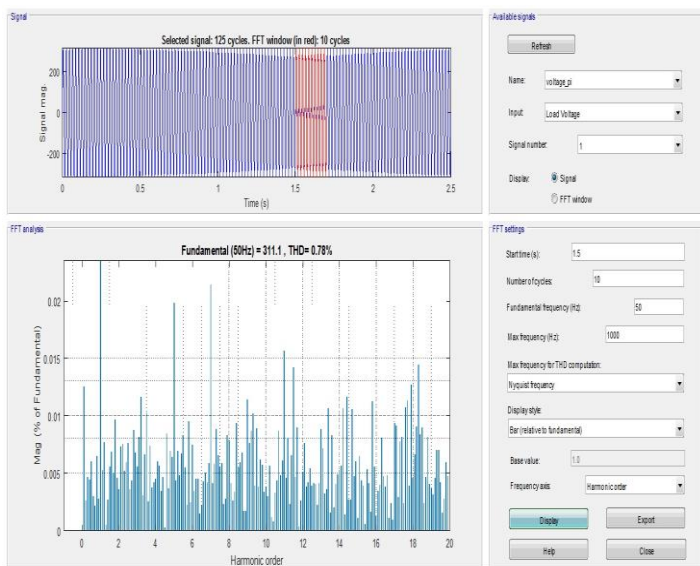

Fig.5 THD analysis of Inverter using SVPWM

As shown in above fig.5 the THD using SVPWM control technique is 0.78%.

6. Simulink Model of DVR with PI Controller

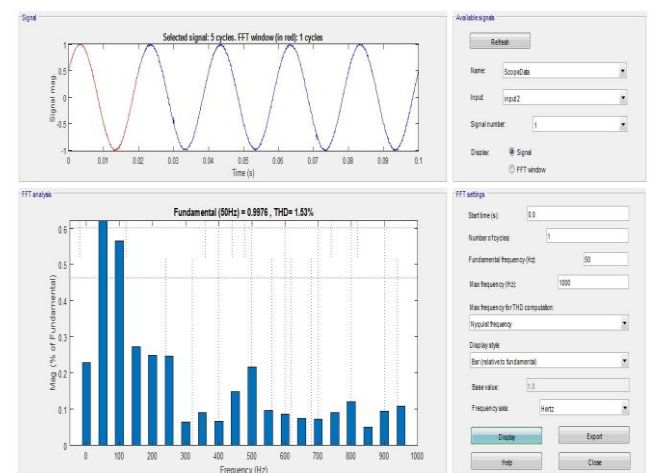

Fig.8 THD of the output voltage of inverter using PI Controller

The above fig.8 shows the THD of two-level inverter using PI controller. The THD of inverter with PI controller is 1.53%.

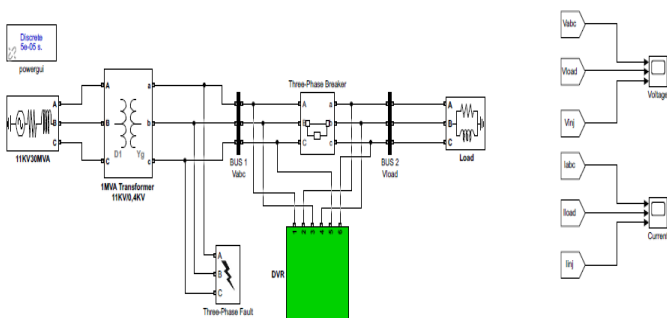

Fig.6 Simulink Model of PI Controller for DVR

8. Simulink Model of DVR with Fuzzy Logic Controller

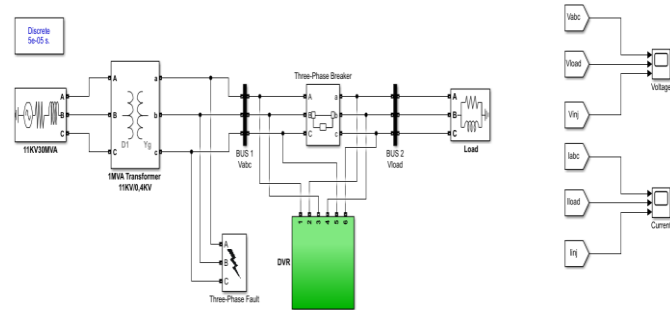

Fig.9 Simulink Model of DVR with Fuzzy Logic Controller

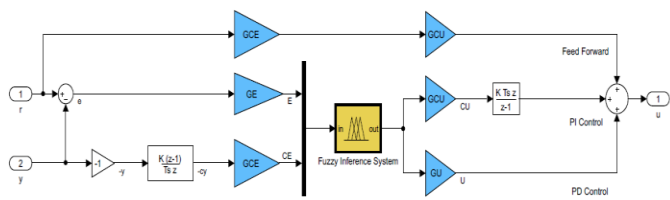

Fig.10 Fuzzy Interface System

Fuzzy logic rules are framed using input and output membership function. After framing the rules, the SVM is replaced by fuzzy logic control toolbox and then fuzzy file will call from FLC toolbox to run the simulation model. The THD analysis of DVR with fuzzy controller is shown in following fig.11.

9. THD Analysis of DVR with Fuzzy Controller

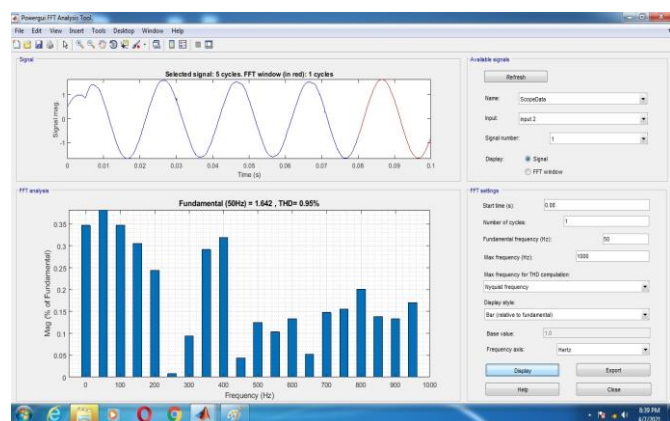

Fig.11 THD Analysis of DVR with Fuzzy Controller

As shown in above fig.11 the THD using fuzzy controller is 0.95%.

10. CONCLUSIONS

This paper is very helpful for selecting the appropriate method for control of DVR. By comparing the fuzzy and SVPWM with PI controller will be helpful to getting the precise control of DVR with minimum losses and with less total harmonics distortion (THD).

From the THD analysis of SVPWM, fuzzy and PI it shows that the SVPWM and Fuzzy have very less THD as compared to the PI controller. So, the SVPWM and fuzzy logic controller are good choice to use over the PI controller technique.

REFERENCES

1. Pravin G. Dhawale, Shrenik R. Sutar¹, Shridhar S. Desai, Swapnil R. Kurne, Akshay A. Chavan Sapura S. Gadakari 'Voltage Compensation Using Dynamic Voltage Restorer (DVR)' *The International Journal of analytical and experimental modal analysis* Volume XII, May 2020
2. Deepak Kumar Dhurwey¹, Dr. Arvind Kumar Sharma 'Enhancing the Power Quality using Dynamic Voltage Restorer (DVR)' *International Journal for Research in Applied Science & Engineering Technology (IJRASET)* June 2018
3. Shazly A. Mohammed¹, Aurelio G. Cerrada², Abdel-Moamen M. A¹, and B. Hasanin 'Dynamic Voltage Restorer (DVR) System for Compensation of Voltage Sags', *International Journal of Computational Engineering Research* (ijceronline.com) Vol. 3 January 2013
4. M. Ramasamy, S. Thangavel 'Photovoltaic Based Dynamic Voltage Restorer with Outage Handling Capability Using PI Controller' *ELSEVIER ICSGCE* September 2011
5. D. Divyalakshmi, N. P. Subramaniam 'Photovoltaic based DVR with Power Quality Detection using Wavelet Transform' *ELSEVIER 1st International Conference on Power Engineering, Computing and Control* March 2017
6. Rakeshwri Pal ¹ *, Sushma Gupta 'Performance analysis of modified dynamic voltage restorer (DVR) employed to a grid-connected solar PV system' *International Journal of engineering and technology* 2018

BIOGRAPHIES



Professor Mrs. Y.N. Bhosale,
Dept. of Electrical Engineering,
RIT collage, Maharashtra, India



P.G. Student Mrs. V. N. Shikhare,
Dept. of Electrical Engineering,
RIT collage, Maharashtra, India