

# A HIGH EFFICIENCY DC/DC CONVERTER FOR HIGH VOLTAGE GAIN HIGH CURRENT APPLICATIONS

Gengadevi<sup>1</sup>, Shanmuga Priya<sup>2</sup>, AbiGowsalya<sup>3</sup>

<sup>1</sup>Assistant professor, Dept of Electrical and Electronics Engineering, P.S.R Rengasamy College of Engineering for Women, Tamilnadu, India

<sup>2</sup>Student, Dept of Electrical and Electronics Engineering, P.S.R Rengasamy College of Engineering for Women, Tamilnadu, India

<sup>3</sup>Student, Dept of Electrical and Electronics Engineering, P.S.R Rengasamy College of Engineering for Women, Tamilnadu, India

\*\*\*

**ABSTRACT** - For a stand-alone solar, Z-source inverter (ZSI) is being preferred because of its single-stage power conversion capability with buck-boost ability. As compared to traditional ZSI, series Z-source inverter (SZSI) reduces the voltage stress on capacitor and inrush current of the inductor significantly. In this project, modes of operation of the SZSI for an induction motor load are explained. When an induction motor runs at a low power factor, an additional mode exists. In this mode, high-magnitude pulses appear on the DC link voltage if the decoupling capacitor is not used with a unidirectional source like solar photovoltaic (PV). In addition, an improved modulation technique is proposed to improve the performance of SZSI. Simulation results show the performance of the proposed scheme. Therefore, SZSI is a promising topology for the solar PV stand-alone system.

**Keywords**--PV system, SZSI, RL load, PWM Generator, 3 phase inverter.

## 1 INTRODUCTION

In the past, high-voltage-gain dc-dc power electronic converters were mainly used for powering HID lamps in automotive headlamps and integrating battery banks onto the high voltage dc bus of UPS's. However, over the last decade, they have been gaining

## 2. RELATED WORKS

Nowadays, bidirectional high voltage conversion ratio dc-dc converters are more applicable in fuel cells, photovoltaic (PV) systems and plug-in hybrid electric vehicles [1]. In these systems, because of the charge and discharge of the used battery under high- and low-load conditions, a bidirectional dc-dc converter is needed to transfer power in two opposite directions [2, 3]. The presented converters in [2, 3] have the same voltage gain as a conventional boost converter. Since the output voltage of PV is low, therefore, these kinds of converters are not more interesting for using in the PV system. On the other hand, non-isolated bidirectional dc-dc converters have power losses lower than

popularity for integration of renewable energy sources. Applications like dc distribution systems, dc microgrids, solid state transformer (SST) and grid-tied inverter systems include a dc bus usually at a voltage of 400V. Renewable sources such as solar panels, fuel cells, etc., typically output power in the voltage range of 20V to 45V. High-voltage-gain dc-dc converters make it feasible for connecting such sources to the high voltage bus by boosting the low voltage from the sources to higher voltages. One of the most recently growing applications is dc distribution systems at 400V. Such systems have been gaining more and more popularity for telecom, data centers, and commercial buildings due to its various benefits. It offers better efficiency, higher reliability at an improved power quality, and low cost compared to the ac distribution systems. The best of all, they offer simpler integration of renewable energy and energy storage. As of now, based on various different studies, 400V dc is being recognized as the optimal voltage level for dc distribution systems. One of the challenges with such systems would be the integration of different renewable sources and energy storage devices. A high-voltage-gain dc-dc converter would be the best solution for integrating low voltage renewable energy sources onto the 400V dc bus.

isolated bidirectional converters [2-4]. In [5-16], several non-isolated high voltage gain boost dc-dc converters have been presented. One way to increase the voltage gain is using the coupled inductors [5, 6]. Another way for increasing the voltage gain is using switched capacitor circuits [7, 8]. In [8], voltage multiplier cells (VMCs) that include switches, capacitors and a third-winding-coupled inductor are used in a dual switch conventional boost converter. In [9], a non-isolated high voltage gain dc-dc converter with low voltage stresses on switches has been presented. This converter increases the voltage gain by using n stages of diode-capacitor-inductor (D-C-L) and m units of VMCs at input and output sides, respectively. In some cases, the voltage gain is increased by interleaving the coupled inductors [10-14]. In these converters, the input current ripple is eliminated for a few special

duty cycles. In these converters, by increasing the phases, the range of zero input current ripples is increased. The presented converters in [10–12] use two three-winding coupled inductors and VMCs that include a diode–capacitor circuit in each phase to achieve high-voltage gain. The presented converter in [11] uses higher number of components to achieve higher voltage gain and lower voltage stresses on switches than the presented converters in [10, 12]. The presented converters in [13, 14] have the same high voltage gain with a coupled inductor and diode–capacitor-based converters. The presented converters in [13, 14] use one and two coupled inductors, respectively. The presented high voltage gain converter in [15] has low voltage stresses on switches and uses two three-winding coupled inductors and a diode–capacitor circuit. The presented interleaved converters in [10–15] can obtain high voltage gain for duty cycle higher than 0.5 ( $D > 0.5$ ). The presented converter in [16] can achieve high voltage gain for the whole range of duty cycles by using a three-winding coupled inductor and a diode–capacitor circuit. All of the presented high voltage gain converters in [5–16] can transfer power only in one direction as boost converters. In [17–21], several high voltage conversion ratio bidirectional dc–dc converters have been presented. The presented converter in [17] has a lower input current ripple than the presented converter in [18]. In the presented bidirectional converters in [19, 20] by using a two-winding coupled inductor, the voltage gain is increased. The presented converter in [20] uses an auxiliary circuit to obtain soft switching operation of switches. The presented converters in [17, 18] have higher voltage gain than the presented converters in [19, 20].

### 3. PROPOSED SYSTEM

In proposed scheme, series ZSI is used as it reduces the size of capacitor and minimizes inductor current, control technique generates the signal for shoot through that employs instantaneous maximum voltage level amongs the reference signal. This reduces shoot through duty ratio and gives opportunity to increase modulating index. Increase in modulating index improves spectral performance. This paper presents the basic idea of drive system using SZSI and then presents new PWM control technique.

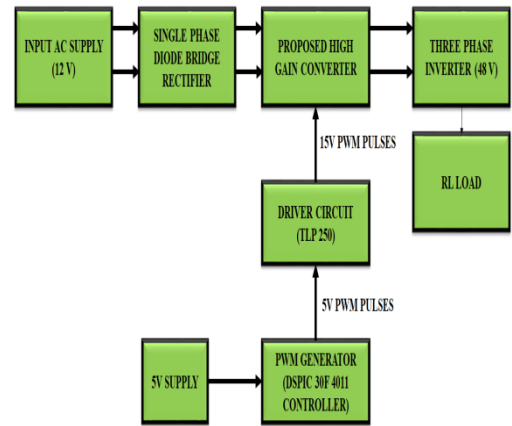

Figure 1 Proposed Block Diagram

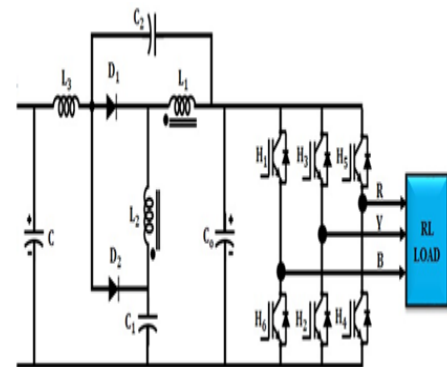

Figure 2 Proposed Circuit Diagram

#### 3.1 SINGLE PHASE DIODE RECTIFIER

A single phase diode rectifier is an uncontrolled rectifier which is used to convert alternating current to direct current. A commonly used single-phase rectifier is shown in the fig 3. A large filter capacitor is connected on the dc side. The utility supply is modeled as a sinusoidal voltage source  $V_s$  in series with its internal impedance, which in practice is primarily inductive. Therefore it is represented by  $L_s$ . To improve the line-current waveform, an inductor may be added in series on the ac side, which will increase the value of  $L_s$ . The objective of this section is to thoroughly analyze the operation of this circuit.

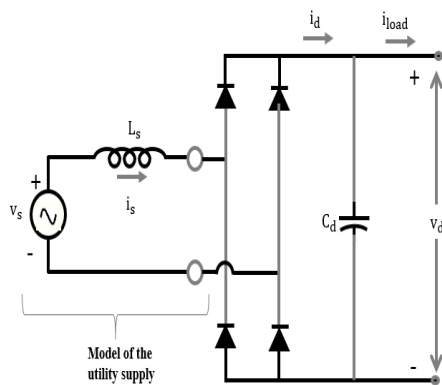

Figure 3 Single Phase Diode Rectifier Inverter

### 3.2 PV SYSTEM

The objective of this section is to determine the detailed electrical characteristics of the PV panel/module from the manufacturer’s specification, on current-voltage plane as well as on power-voltage plane, so that the output of the PV panel can be predicted under specific electrical loads.

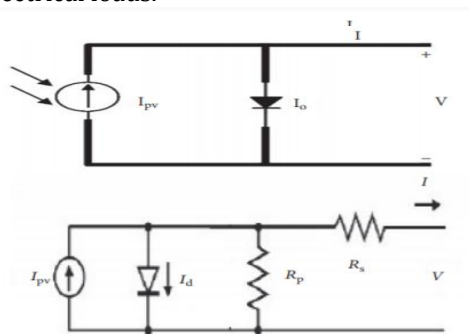

Figure 4 PV Panel

Figure 4 showed the equivalent circuit of a theoretical PV cell, while Figure shows equivalent circuit of a practical PV device including the series and parallel resistances. And the basic equation from the theory of semiconductors that mathematically describes the characteristic of the ideal PV cell is

$$I = I_{pv,cell} - I_{0,cell} \left[ \exp \left( \frac{qV}{aKT} \right) - 1 \right]$$

$$I_d = I_0 \left[ \exp \left( \frac{qV}{aKT} \right) - 1 \right]$$

Those parameters are measured with reference to standard test conditions (STCs) of solar irradiation and cell temperature. The basic electrical parameters are not enough to investigate the performance of a PV panel. Hence, it is crucial to find out detailed electrical characteristics which model the performance of PV panel.

### 3.3 SVPWM TECHNIQUE

Sinusoidal PWM has been commonly used as popular PWM technique in many Power Electronics Applications, especially in AC motor control like V/F control of AC induction motor.

It will be shown in this chapter that another PWM technique called Space Vector PWM is better than Sinusoidal PWM. SV-PWM utilise the available DC bus voltage by 15% more than sine PWM. It will be shown that SV-PWM can directly transform the stator voltage vectors from  $\alpha$ - $\beta$  Co-ordinate system to pulse width modulation signals.

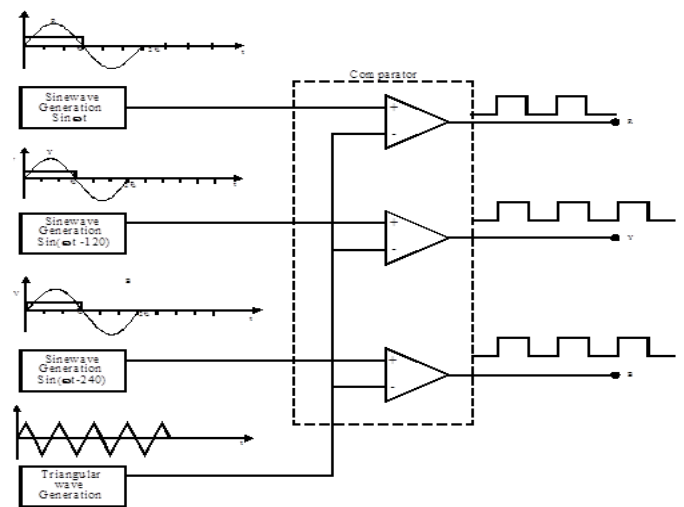

Figure 5 PWM generation sinusoidal technique

A single phase vector (the desired reference vector) is resolved onto  $\alpha$ - $\beta$  co-ordinate and used for generating the PWM signals. Hence there is no error from the input stage. In case of sine PWM, 3 separate sine waves are compared with triangular carrier to generate the PWM signals. If there is an error in the three input sine waves, then the inverter output waveforms will not be balanced. In this case, the SV-PWM has become advantageous.

In a sinusoidal PWM, 3 separate sine modulating waveforms are generated and compared individually with a triangular carrier waveform to produce pulses for driving the inverter switches. Hence each pulses is treated individually as shown in figure.

This method will not make full use of the inverters DC supply voltage. The asymmetrical nature of this sine PWM produces high harmonics distortion in the supply.

This can be digitally implemented as shown in Fig 5 Here an Up/Down counter is used as the triangular waveform generator.

The Up/Down counter value for every  $T_{PWM}$  is compared with 3 compare registers to provide 6 PWMs. The corresponding sine values of the modulating

waveform is loaded into the registers from the sine look up tables.

### 3.4 INVERTER SWITCHING

The concept of space vector is derived from the rotating field of AC machine. When the 3 phase voltage spaced by  $120^\circ$ , is applied to an AC machine it produces a rotating flux in the air gap of the AC machine. This resultant flux is constant and rotating at a speed of  $\omega$  rad/s. This is explained in appendix - A. This resultant rotating flux can be represented as a single rotating voltage vector.

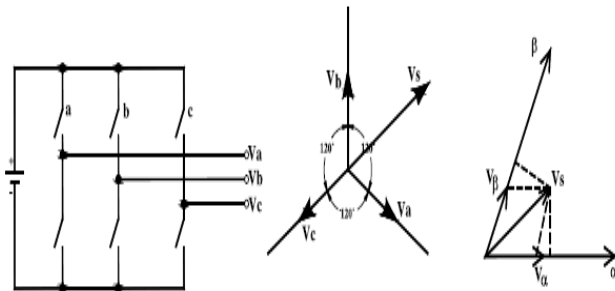

Figure 6 Inverter Logic

The space vector modulation technique can be best understood by applying the resultant space vector of the 3 phase voltage to Inverter. In space vector modulation, the 3 output voltage is treated as a single quantity "rotating voltage vector",  $\overline{V_s}$ .  $\overline{V_s}$  can be resolved into 3 quantities  $V_a$ ,  $V_b$  and  $V_c$ .

In Sine PWM, by comparing the modulating sine voltage with a triangular waveform the switching signal for the 3 top switches of the inverter can be produced. By varying the 3 sine wave's voltages and frequencies, the inverter output voltage and frequency are varied. Whereas in SVPWM, once the output 3 phase voltage is fixed or known, then this 3 phase quantity is converted to a single phase vector,  $\overline{V_s}$  in  $\alpha - \beta$  axis. Now this  $\overline{V_s}$  in 2 dimension is used in various formulae (discussed later) to derive the switching signals for the 3 top switches of the inverter. This is discussed later in this manual.

This is almost reverse process of sine PWM. In sine PWM one generates 3 sine modulation voltages to generate 3 separate PWMs by comparing with a single triangular wave form. In SV modulation, once the output 3 phase voltages are known, then a single space vector

$\overline{V_s}$  is calculated in  $\alpha - \beta$  axis. This vector,  $\overline{V_s}$  in  $\alpha - \beta$  axis is applied as a single quantity to the 6 switches of the inverter. Since is the 2 dimension quantity it is easier to derive various formulae to find out the ON period of

PWMs for the 3 top switches. This space vector is a compact notation that a single variable contains information about the voltages of all three phase at any given time. The space vector can be better understood if one knows the three phase to two phase transformation.

## 4. DESCRIPTION

### 4.1 POWER SUPPLY

There are many types of power supply. Most are designed to convert Voltage AC Mains electricity to a suitable low voltage supply for electronic Circuits and other Devices. A power supply can be broken down into a series of blocks, each of which performs a particular function.

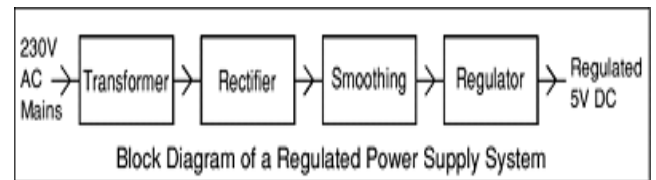

Figure 7 block diagram of regulated power supply

Transformer - steps down high voltage AC mains to low voltage AC.

Rectifier - converts AC to DC, but the DC output is varying.

Smoothing - smoothes the DC from varying greatly to a small ripple.

Regulator - eliminates ripple by setting DC output to a fixed voltage.

Here the AC supply main is given to the step down transformer. The transformer having the different voltages. The output from the transformer is given to the rectifier circuit. In this rectifier circuit the AC voltage is converted to DC voltages. The rectified DC voltage is given to the regulator circuit. The output of the regulator is depends upon the regulator IC chosen in the circuit.

### 4.2 REGULATOR

Voltage regulators ICs are available with fixed (typically 5, 12 and 15V) or variable Output voltages. They are also rated by the maximum current they can pass. Negative Voltage regulators are available, mainly for use in dual supplies. Most regulators include some automatic protection from excessive current ('overload protection') and Overheating ('thermal protection').

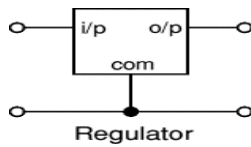

Figure 8 Regulator



Figure 9 Regulator IC

Many of the fixed voltage regulator ICs has 3 leads and look like power transistors, Such as the 7805 +5V 1A regulator shown on the right. They include a hole for attaching a heat sink if necessary.

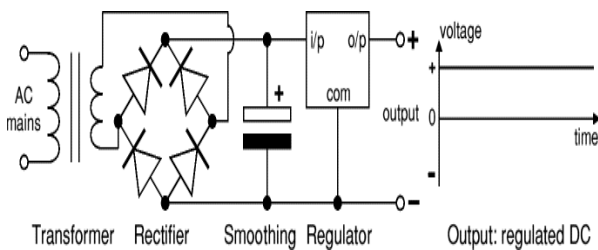

Figure 10 Rectifier circuit diagram and wave form

The regulated DC output is very smooth with no ripple. It is suitable for all electronic circuits. In generally there are two types of regulators are used. Namely positive and negative type regulators. For positive type regulators 78\*\* series of regulators are used. For negative type regulators 79\*\* series of regulators are used. Depends upon the voltage and type of the voltage the regulator IC is selected.

### 4.3 DRIVER CIRCUIT DIAGRAM

IR2110 IC is used to drive the MOSFET'S. The output of the opto-isolator is given to the IR2110 ic. There are two output signals are generated from the drive ic namely both the output pulses are inverted to each other. The impedance of the MOSFET is more, so the signals which is given to the gate should be high gain for that the driver ic is used in MOSFET based circuits. A MOSFET drive circuit is designed to connect the gate directly to a voltage bus with no intervening resistance other than the impedance of the drive circuit switch. Gate driver acts as a high-power buffer stage between the PWM output of the control device and gates of the primary power switching MOSFET.

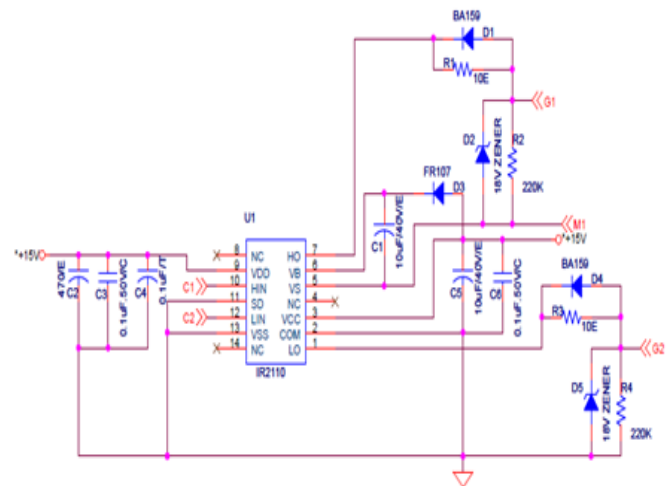

Figure 11 Driver circuit diagram

### 4.4 H-BRIDGE CIRCUIT DIAGRAM

To synthesize a multilevel waveform, the ac output of each of the different level H-bridge cells is connected in series. The synthesized voltage waveform is, therefore, the sum of the inverter outputs. The number of output phase voltage levels in a cascaded-inverter is defined by

$$M=2s+1$$

where 'M' is no of levels of o/p voltage.  
 's' is the number of dc sources.

Because zero voltage is common for all inverter outputs, the total level of output voltage waveform becomes 2s+1. Each inverter bridge is capable of generating three different levels of voltage outputs. When the positive group switches are turned on, the voltage across that particular bridge is positive. When the negative group switches are turned on the voltage across that particular bridge is negative.

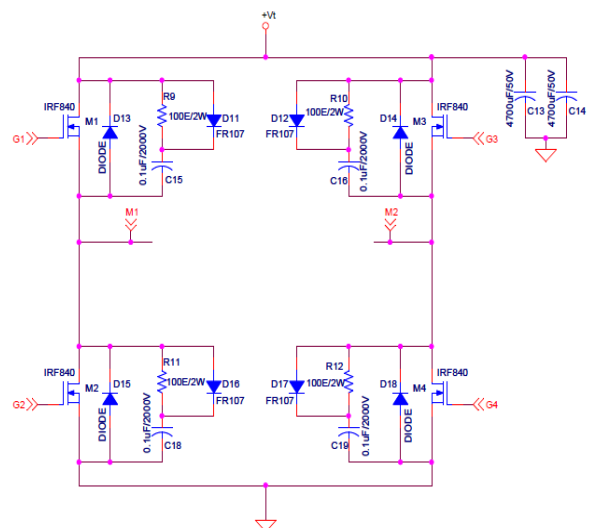

Figure 12 H-Bridge Inverter Circuit

In this project the switching device used is MOSFET IRF 840. The voltage rating is 500v and the current rating is 8 A. Resistance and Capacitor (RC) snubber circuit is connected across the all the switching devices. This snubber circuits give the protection to switching devices from the  $dv/dt$  and  $di/dt$ . One diode also connected across the switching devices, this diodes are circulate the current at the same time reverse bias the reverse currents which is flows to the switching devices.

#### 4.5 ABOUT DSPIC CONTROLLER

Microchip Technology’s Motor Control & Power Conversion family of dsPIC Digital Signal Controllers provides an easy-to-use solution for applications requiring motor control. Microchip Technology introduced 20 16-bit Flash micro controllers that provide the industry’s highest performance.

The dsPIC family of Digital Signal Controllers features a fully- implemented digital signal processor (DSP) engine, 30 MIPS non-pipelined performance, C compiler friendly design, and a familiar Microcontroller architecture and design environment. The 20 new dsPIC30F2010 devices form three product families targeting motor control and power conversion, sensor, and general-purpose applications.

The dsPIC core is a 16-bit (data) non-pipelined modified Harvard machine that combines the control advantages of a high-performance 16-bit Microcontroller with the high computation speed of a fully implemented DSP to produce a tightly coupled, single-chip single-instruction stream solution for embedded systems designs. The initial 20-dsPIC30F2010 devices feature 12 Kbytes to 144 Kbytes of on-chip secure Flash program memory space and up to eight Kbytes of data space Operating voltage appeals to many Microcontroller applications that remain at 5 volts, while many DSPs are restricted to 3.3-supply V maximum. Devices are planned in 40-pin package.

#### 4.6 MOTOR CONTRAL PWM MODULE IN DSPIC

The dsPIC motor control PWM module is optimized for applications, such as 3-phase AC induction motors, 3-phase brushless DC motors, and switched reluctance motors.

The motor control PWM module has either 6 or 8 output pins and 3 or 4 PWM generators, depending upon the device. The output pins may be configured as complementary output pairs or as independent outputs.

Critical PWM operating parameters, such as output polarity, are programmed in non-volatile memory for safety. The non-volatile options reduce the risk of placing the PWM outputs in a state that might damage the power devices connected to Peripheral.



**Figure 13** DSPIC30F2010 Micro Controller

### 5. RESULTS AND DISCUSSIONS

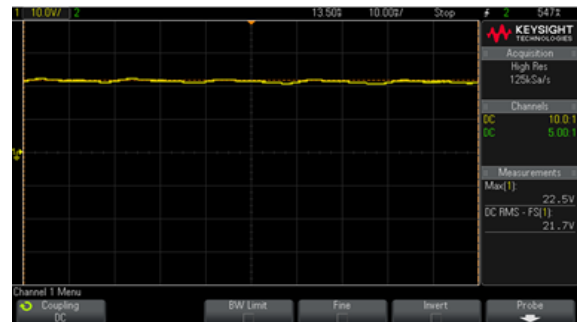

**Figure 14** Input voltage from the source

The figure 14 shows the output voltage from the source system, its having higher order ripples due to oscillatory renewable energy resources. This voltage is given to the converter, this converter will reduce the ripples.

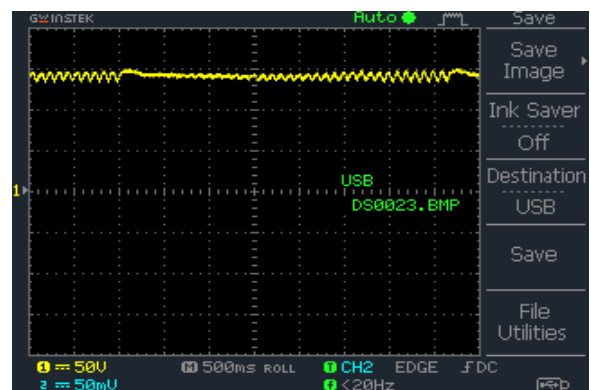

**Figure 15** Z Source output voltage

The figure 15 shows the Z source converter output voltage. The converter is the second order filter, this will suppress the ripple contents in the DC voltage from the input DC voltage.

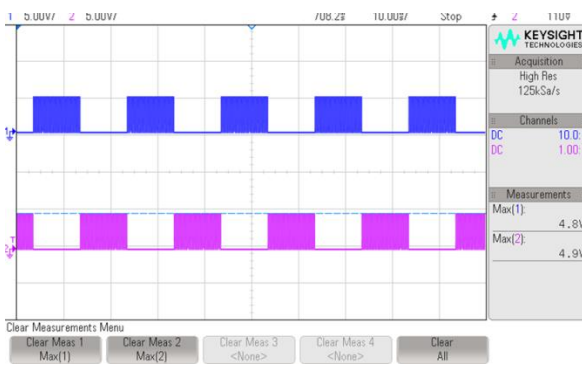

Figure 16 PWM pulses to the inverter

The figure 16 shows the PWM pulses to the voltage source inverter, the pulses having 180 degree phase displacements. The pulse has produced using sinusoidal pulse width modulation technique.



Figure 17 Inverter output voltage

The figure shows the inverter output voltage, it has some noises due to the THD. This AC voltage is given to the load.

## 6. CONCLUSION

This project has presented a new Z-source inverter topology. Compared to the previous Z-source inverter, the improved topology has several merits. 1) The Z-source capacitor voltage stress is reduced greatly to perform the same boost ability; thus, low-voltage capacitors can be utilized to reduce the system cost and volume; 2) The inrush current and resonance of Z-source capacitors and inductors in traditional topology can be suppressed with a proper soft-start strategy. The space vector PWM technique reduces the DC utilization and reduces the losses. Simulation and experimental results verified the aforesaid merits of the proposed topology.

## REFERENCES

[1] Hsieh, Y.P., Chen, J.F., Yang, Sh.L., et al., "High-conversion-ratio bidirectional dc-dc

converter with coupled inductor", IEEE Trans. Power Electron., 61, (1), pp. 210-222, 2014.

[2] Babaei, E., Saadatizadeh, Z., "A new interleaved bidirectional dc/dc converter with zero voltage switching and high voltage gain: analyses, design and simulation", Int. J. Circuit Theory Appl., 45, (11), pp. 1773-1800, 2017.

[3] Babaei, E., Saadatizadeh, Z., Laali, S., "A new topology of bidirectional buck-boost dc/dc converter with capability of soft switching and input current ripple cancellation", Ir. J. Electr. Electron. Eng., 12, (2), pp. 134-146, 2016

[4] Yao, C., Ruan, X., Wang, X., et al, "Isolated buck-boost dc/dc converters suitable for wide input-voltage range", IEEE Trans. Power Electron., 26, (9), pp. 2599-2613, 2011.

[5] Zhao, Y., Li, W., He, X., "Single-phase improved active clamp coupled-inductor-based converter with extended voltage doubler cell", IEEE Trans. Power Electron., 27, (6), pp. 120-134, 2012.

[6] Kim, J.K., Moon, G.W., "Derivation, analysis, and comparison of non-isolated single-switch high step-up converters with low voltage stress", IEEE Trans. Power Electron., 30, (3), pp. 1336-1344, 2015.

[7] Liu, H., Li, F., Ai, J., "A novel high step-up dual switches converter with coupled inductor and voltage multiplier cell for a renewable energy system", IEEE Trans. Power Electron., 31, (7), pp. 4974-4983, 2016.

[8] Hsieh, Y.P., Chen, J.F., Liang, T.J., et al, "Novel high step-up dc-dc converter with coupled-inductor and switched-capacitor techniques", IEEE Trans. Ind. Electron., 59, (2), pp. 998-1007, 2012.

[9] Nouri, T., Babaei, E., Hosseini, S.H., "A generalized ultra step-up dc-dc converter for high voltage application with design considerations", Electr. Power Syst. Res, 105, pp. 71-84., 2013.

[10] Babaei, E., Saadatizadeh, Z., Mohammadiivatloo, B., "A new interleaved bidirectional zero voltage switching dc/dc converter with high conversion ratio", J. Circuits Syst. Comput., 26, (6), pp. 1-25, 2017.

[11] Nouri, T., Hosseini, S.H., Babaei, E., et al.: 'Interleaved high step-up dc-dc converter based on three-winding high-frequency coupled inductor and voltage multiplier cell', IET Power Electron., 8, (2), pp. 175-189, 2015.

[12] He, L., Liao, Y., "An advanced current-auto-balance high-step-up converter with a multi-inductor and voltage multiplier for a renewable power generation system", IEEE Trans. Power Electron., 31, (10), pp. 133-143, 2016.

- [13] Revathi, B.S., Prabhakar, M, “Transformerless high-gain dc-dc converter for microgrids”, IET Power Electron., 9, (6), pp. 1170–1179, 2016.
- [14] Hu, X., Dai, G., Wang, L., et al, “A three-state switching boost converter mixed with magnetic coupling and voltage multiplier techniques for high gain conversion”, IEEE Trans. Power Electron., 31, (4), pp. 2991–3001, 2016.
- [15] Tseng, K.C., Chen, J.Z., Lin, J.T., et al, “High step-up interleaved forward-fly back boost converter with three-winding coupled inductors”, IEEE Trans. Power Electron., 30, (9), pp. 4696–4703, 2015.
- [16] Tseng, Ch., Lin, J.T., Huang, Ch.Ch, “High step-up converter with three-winding coupled inductor for fuel cell energy source applications”, IEEE Trans. Power Electron., 30, (2), pp. 574–581, 2015.
- [17] Ardi, H., Ajami, A., Kardan, F., et al, “Analysis and implementation of a non-isolated bidirectional DC-DC converter with high voltage gain”, IEEE Trans. Power Electron., 63, (8), pp. 4878–4888, 2016.
- [18] Ardi, H., Ahrabi, R.R., Najafi Ravadanegh, S, “Non-isolated bidirectional dc-dc converter analysis and implementation”, IEEE Trans. Power Electron., 7, (12), pp. 3033–3044, 2014.
- [19] Narasimharaju, B.L., Dubey, S.P., Singh, S.P., “Design and analysis of coupled inductor bidirectional dc-dc convertor for high-voltage diversity applications”, IET Power Electron., 5, (7), pp. 998–1007, 2012.
- [20] Das, P., Mousavi, S.A., Moschopoulos, G., “Analysis and design of a non-isolated bidirectional ZVS-PWM dc-dc converter with coupled inductors”, IEEE Trans. Power Electron., 25, (10), pp. 2630–2641, 2010.