

FARMER'S AID-MODERN AGRO BASED IoT DEVICE

N.SENTHAMILARASI¹, P.VARSHA², R.KRITHIKA³G.KIRUTHIKA⁴

¹Assistant Professor, Department of Information Technology, Panimalar Institute of Technology, Chennai, India

^{2,3,4}Student, Department of Information Technology, Panimalar Institute of Technology, Chennai, India.

Abstract - Almost all countries are working to improve agricultural activities and they are trying to overcome those problems caused by traditional agricultural system such as exploitation of water and natural resources. When it comes to agriculture man power is much needed which is also a major factor affecting it. People even today do not use proper pest/disease control mechanism, crop management system and quality management system. Proper nutrients for plants is essential which can help the promotion of their growth. It is important to maintain the quality of the soil for productive plant growth. Hence, a technology which is primarily used to watch agricultural field is greatly needed for farmers in developing countries which provides a correct management of the crops. In order to solve the above problem the solution we prefer is "FARMER'S AID –Modern agricultural based IoT device". The projected work mainly concerns about irrigation and the management of nutrients in the soil needed for the promotion of plant growth.

Key Words: Farmer, Agriculture, Soil Moisture, Temperature, Monitoring, Sensors, Calculation, Data.

1. INTRODUCTION

Agricultural field has a variant of nutrients that are required for the promotion of growth of plants. These nutrients play a important role for the production of better crops. Tamil Nadu is predominant on two kinds of soils that has different nutrient content whereas on the other hand, the other two type of soils are dry in condition that are useful for the production of cotton etc. The field needs to be monitored for the moisture content present in the soil, the nutrient content for the growth of plants, the environmental conditions, the water required or that is present for the supply. On these notes, the factors are taken into consideration for calculating the moisture content, water level present, the temperature and the NPK content present in the soil. Through raspberry Pi 3, a set of sensors will be connected that calculates these factors and send these values as input to the system. In the system, actually cloud plays a major role for calculating the values or comparing the values with the dataset fed into the system.

The values of nutrient content will be considered as input which is needed to be compared with the dataset containing the plant with their specified accurate nutrient values. From

the comparison, the most comparatively selected crop will be suggested for cropping that could manage with the nutrients present in the soil and also helps for the betterment of production of crops. The moisture content from the soil is calculated continuously for checking the wet condition of the soil that keeps the plant to be moisture and prevents from dry conditions. The Temperature sensor is used for checking with the environmental conditions that goes with the flow of determining that whether rain can come or not so that the irrigation of plants cannot take place for the plant health.

The water level sensor is actually used for checking the water availability in the resource. If water is present above to a marked level irrigation can be done automatically. If the water is below the marked level it sends notification to the farmer regarding the water needs. This constitutes the Internet of Things(IoT). An AC motor is driven by the force to irrigate the field, where a relay is connected. Cloud servers possess and exhibit similar capabilities and functionality to a typical server but are accessed remotely by a cloud service provider. A cloud server may also be called a virtual server or virtual private server. Here we use a private cloud which is purchased and owned by a private owner. The cloud is used to store data and information of the user. The cloud is more secured by providing user name and password which can be accessed only by the owner. Cloud computing relies on sharing of resource coherence and economics of scale and public utility. Hyper Text Transfer Protocol (HTTP) is a protocol is used to transfer the data over the web. It is the part of internet protocol and defines commands and services used for transmitting web pages and data.

2.RELATED WORK

Internet of Things (IoT) is the future. Being able to monitor and control things from a distance makes any task effortless. Author in paper[1] says that the yield of any crop can be maximized with the help of precision agriculture Their system uses pressure sensor, temperature sensor, humidity sensor, soil moisture sensor and camera that helps for crop selection, crop monitoring and crop maturity identification.

In Paper [2] various sensors are deployed in the field like temperature sensor, moisture sensor and PIR sensor and are connected to the microcontroller through RS232. The hardware components include the microcontroller, buzzer, relay, ADC converter, GSM module and the sensors are interfaced. Which result is the output from the Android

Application that is developed in the mobile phone that determines the temperature, humidity, moisture and the intruder detection along with irrigation control.

In paper [3] The system is used to control high voltage electrical devices like pump, flap of playhouses etc. without human intervention depending on environmental parameters like soil moisture and temperature. Different level of soil moisture and temperature value were sensed and based on predefined threshold value of soil moisture and temperature, Arduino board controls the high voltage farming equipment without human intervention. In the absence of human being in the agriculture field, this system provides continuous field monitoring and triggers the appropriate events according to the requirement.

In the paper [4] a design for smart IoT communication is presented which requires joining IoT, Wireless Sensor Network and mapping aerial. The paper calculates the bandwidth when different commands and data are sent by the system. The designed system is controlled remotely using a mobile phone.

In this paper [5], The system to optimally water agricultural crops based on a wireless sensor network is been developed. This work aimed to design and develop a control system using node sensors in the crop field with data management via smartphone and a web application. The final component is mainly used to control crop watering through a mobile application in a smartphone either automatic or manual control by the user.

Paper[6]The cloud computing devices that can create a whole computing system from sensors to tools that observe data from agricultural field images and from human actors on the ground and accurately feed the data into the repositories along with the location as GPS coordinates.

Paper [7]This idea proposes a novel methodology for smart farming by linking a smart sensing system and smart irrigator system through wireless communication technology. Paper [8]It proposes a low cost and efficient wireless sensor network technique to acquire the soil moisture and temperature from various location of farm and as per the need of crop controller to take the decision whether the irrigation is enabled or not.

3.PROPOSED SYSTEM

The main idea of the designed system is continuous monitoring of the field over internet where the data is collected from smart sensors and stored in the cloud. Our proposed work is about using a raspberry-pi kit in which the sensors, motor, a relay device is connected. It uses NPK sensor for predicting the nutrient content present in the soil

which gives more accuracy for the selection of crops. It uses Supervised Learning Algorithm which has definite values on both sides for comparison that doesn't need any prior knowledge about the type of soil. It monitors the field during all the crop stages which is calculated by the duration of each crop stage fed into the system.

4.ARCHITECTURE DIAGRAM

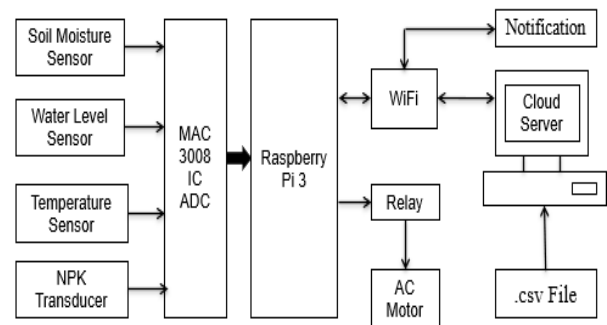

5.DATA COMPARISON

Initially all parameters that are required for plant will be obtained and set. The nutrients content present in the soil will be collected through NPK device and this acts as an input. The collected data will be compared with the dataset that is already set in the program and helps to predict what kind of plants could be grown in that type of soil. The most accurate nutrient content compared will be selected. If any two plants match with the nutrient content, then the user will get the details about both the plants. The information may include the total duration of the plant growth and our system also continuously monitor the land and finds if there is need of additional nutrients that are required during growth period.

6. FIELD MONITORING

To obtain an accurate measurement of moisture content in soil, a soil temperature sensor is also required for calibration. Here we use LM358 sensor. The LM358 is a low power dual operational amplifier integrated circuit. DHT11 is a humidity sensor which features digital temperature & humidity sensor complex with a calibrated digital signal output. Resistive type humidity sensors pick up changes in the resistance value of the sensor element in response to the change in the humidity. NPK sensor is required for calibration that are resistant to long-term electrolysis and corrosion, and uses high-density epoxy resin. The soil moisture level, the nutrients level will be monitored continuously through the sensors. The values will be stored

in Thing Speak and the data will be compare. When there is not sufficient moisture content or nutrient content in the soil then the user will get a notification about it.

7. OUTPUT MESSAGE

The data collected from the sensors is sent to the cloud. The data is sent through the network that have been connected to the kit. The owner of the land will receive the status of the field through mail and SMS. A separate user name and a password will be given to the user through which he will access the web page where the data have been stored.

Fig.1.1

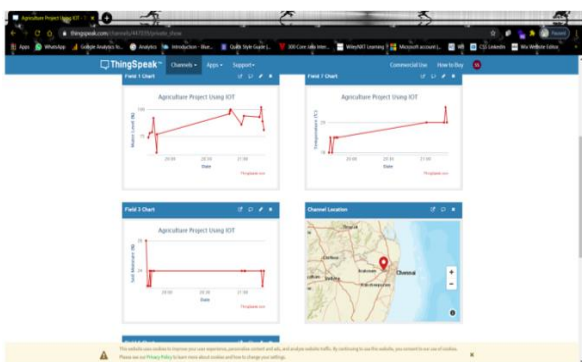

Fig 1.2

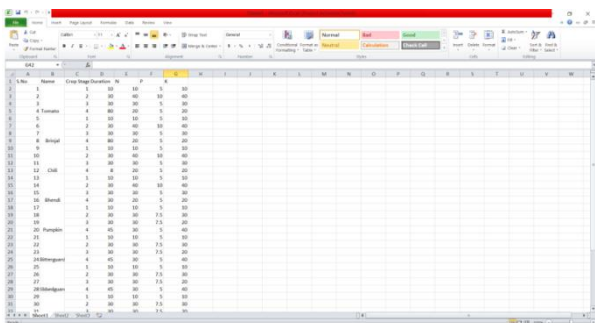

Fig 1.3

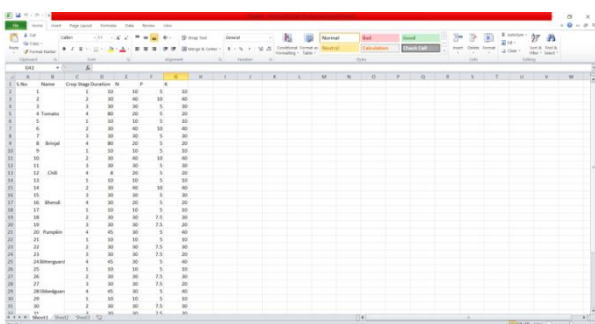

Fig 1.4

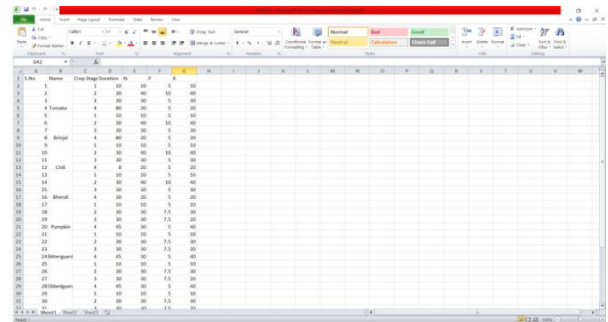
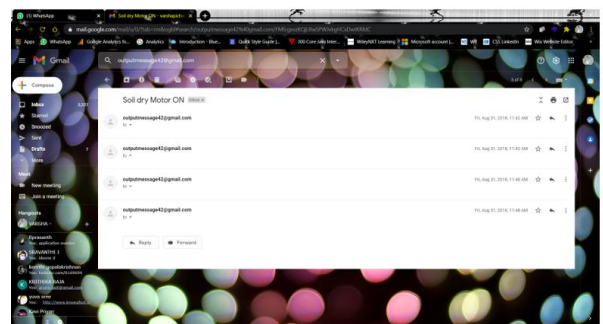

Fig 1.5



8.CONCLUSION

Better improvement of production in crop is a major challenge in well developing country like India. So In order to reach, we propose a new agriculture technology based on IOT association with cloud computing. This system made with ability for further improvement by incorporating new self learning techniques in which easy deployment in to cloud to understand behaviour of sensor collected data and can take individual or autonomous decisions. The selection of crops based on the nutrient will be an additional glow to the system which helps for the great production to meet the immediate requirements.

9.REFERENCES

[1] Yash Bhojwani, RishabSingh , Rachana Reddy and Boominthan Perumal – “ Crop Selection and IoT Based Monitoring System for Precision Agriculture ” 2020 International Conference on Emerging Trends in Information Technology and Engineering (IC-ETITE)

[2] Suma, N., Samson, S. R., Saranya, S., Shanmugapriya, G., &Subhashri, R. (2017). IOT based smart agriculture monitoring system. International Journal on Recent and Innovation Trends in computing and communication, 5(2), 177-181.

[3] MD Ashifuddin Mondal and Zeenat Rehana – “ IoT based Intelligent Agricultural Field Monitoring System ” IEEE 2018, Second International Conference on Advanced

Computational and Communication Paradigms (ICACCP-2019)

[4] Cambra, C., Sendra, S., Lloret, J., & Garcia, L. (2017, May). An IoT service-oriented system for agriculture monitoring. In 2017 IEEE International Conference on Communications (ICC) (pp. 1-6). IEEE

[5] Jirapondmuangprathub, Nathaphon Boonnama Siriwan, Kajornkasirata Narongsak, Lekbangponga, Apirat Wanichsombata and Pichetwut Nillaorb – “ IoT and agriculture data analysis for smart farm ” Computers and Electronics in Agriculture 2018

[6] M.K. Gayatri, J. Jayasakthi, Dr. G.S. Anandhamala, “Providing Smart Agriculture Solutions to Farmers for Better Yielding Using IoT”, IEEE International Conference on Technological Innovations in ICT for Agriculture and Rural Development (TIAR 2015).

[7] Chetan Dwarkani M, Ganesh Ram R, Jagannathan S, R. Priyatharshini, “Smart Farming System Using Sensors for Agricultural Task Automation”, IEEE International Conference on Technological Innovations in ICT for Agriculture and Rural Development (TIAR 2015).

[8] S. R. Nandurkar, V. R. Thool, R. C. Thool, “Design and Development of Precision Agriculture System Using Wireless Sensor Network”, IEEE International Conference on Automation, Control, Energy and Systems (ACES), 2014.

[9] Micah Bogdanoff and Shahab Tayeb – “ An ISM-Band Automated Irrigation System for Agriculture IoT ” 2020 IEEE for Carleton University, IEEE 2020

[10] ZENG HU, LONGQIN XU, LIANG CAO, SHUANGYIN LIU, ZHI JIE LUO, JING WANG, XIANGLI LI AND LU WANG – “ Application of Non Orthogonal Multiple Access in Wireless Sensor Networks for Smart Agriculture ”