

Microstrip Patch Antenna: A Review and the Current State of the Art

Sachin Pathak¹, Shailesh Kumar Singh²

¹Student M.Sc(Physics), Monad University, Hapur

²Associate professor, Department of Physics, Himalayan Garhwal University Uttarakhand

Abstract -The cell generation is fast-growing in recent times because of its huge effect on social life. Accordingly, there may be a want to observe the development of the antenna structures as they may be taken into consideration as center gadgets for wi-fi generation. The contemporary-day antenna designs permit a unmarried detail to be hired in lots of structures. The microstrip patch antennas are basically taken into consideration withinside the development of the cutting-edge conversation mechanisms in comparison to the traditional kind due to the fact they provide the benefit of being low profile together with easy or less expensive production procedures. In the latest 4 decades, vast studies has been done at the antenna structures. Consequently, this evaluate paper offers a complete account of the previous and next studies achievements of the microstrip patch antennas. The diverse styles of structures taken into consideration for contrast encompass millimeter-wave, large banding, dual/multi-band or reconfigurable structure, size-reduction, compact, low profile, impedance bandwidth, excessive benefit or linear and round polarization applications.

Key Words: (Size 10 & Bold) Key word1, Key word2, Key word3, etc (Minimum 5 to 8 key words)...

1. INTRODUCTION

Taking under consideration the presumptions of the close to future, the data-hungry devices (smart-phone, tablet, sensor and etc.) will cause a scarcity withinside the bandwidth. Hence, the development of wi-fi-primarily based totally networks is essential. The 5G era employs excessive frequency bands and huge sign bandwidth as a way to boom the transmission bit rates, thereby supplying higher insurance with low battery consumption [1]. In the current fifteen years, the microstrip patch antennas (MPAs) are the maximum swiftly growing structures withinside the antenna field. They have acquired innovative interest from the researchers global and numerous patents, articles or books were published. Also, more than one symposium classes and quick guides were executed. As a result, MPAs have quick advanced from an educational novelty to business reality, with packages in a huge kind of microwave structures.

The traditional MPAs includes a patch on one facet of a dielectric substrate and floor aircraft on the opposite facet of the substrate which is largely fed with the aid of using a microstrip line or coaxial probe [2]. MPAs provide some of benefits over the opposite antenna structures consisting of low profile, lightweight, easy fabrication process, low fee

and clean integration with monolithic microwave included circuits (MMICs). They additionally display the inherent resonant overall performance and green slim bandwidth operation [2]. Moreover, the ultra-wideband (UWB) MPAs have attracted extra interest in current years because of their severa advantages over the conventional antenna factors consisting of reflectors, horns, slots, or cord antennas.

However, the electric overall performance of the simple MPAs or array suffers from numerous critical drawbacks, for instance, slim bandwidth, excessive feed community losses, terrible go polarization, and coffee strength dealing with capacity. Consequently, in current years, big interest has been paid with the aid of using many antenna designers to decorate numerous traits of the MPAs at the side of unique packages like millimeter-wave, global interoperability for microwave access (WiMAX), wi-fi nearby region community (WLAN) and UWB. This paper consists of a evaluate of the extraordinary strategies provided with the aid of using researchers for reinforcing the bandwidth and the benefit of the MPAs. It accompanied with the aid of using summarized dialogue of layout strategies and conclusion.

2. HISTORICAL REVIEW

Microstrip might be the maximum a hit and innovative antenna generation ever. Its achievement comes from very famous advantages. And it additionally has a few limitations, the maximum famous being the inherent slim bandwidth, slim impedance, low axial ratio (AR), small benefit, decrease energy coping with potential and coffee efficiency. Several strategies were advanced to growth the bandwidth and were offered in [3-4]. Microstrip antenna changed into conceived via way of Deschamps [5] in 1953 in USA. In 1955, Gulton and Bassinot [6] in France patented; I flat aerial that may be used withinside the UHF region. The father of sensible microwave patch antennas is seemed as [7]. Although the patch antenna changed into first theorized via way of [5], however it changed into now no longer placed to apply for plenty years. The first on a statistics hyperlink for facet winder missile, then on sprintmissiles semi-energetic seeker in [8]. The assemble of microstrip radiator wasnt energetic until the primary 1970s, as soon as there has been a proper away would really like for low profile conformal antennas at the growing new era missiles. The first microstrip radiator changed into built via way of Byron [7] withinside the early 1970s. This receiving cord changed into a directing strip, some wavelengths in duration and 1/2 of wavelength huge remoted from a floor aircraft via way of a

dielectric strip. The strip changed into nourished at intermittent interims making use of co-axial connectors alongside the emanating edges and changed into applied as an array. Munson [8] in 1974 established new magnificence of microstrip wrap round antennas appropriate for missiles the use of microstrip radiator and microstrip feed networks at the identical substrate.

In the early Nineteen Eighties, the country of patch antenna may be partly summarized; the majority of the studies centered at the traits of square, round, annular-ring and equitriangular patches have been in large part hooked up theoretically (thru hollow space model) and established experimentally. Typical traits of the bottom mode are broadside radiation styles approximately 6 dBi benefit and 3% impedance bandwidth. Narrow bandwidth changed into extensively identified as a hassle and there has been full-size hobby in frequency tuning, wide banding strategies and complete wave techniques have been being advanced. [9-16]. Beginning withinside the mid-Nineteen Eighties and in the course of the 1990s, a whole lot of studies changed into dedicated to increase the bandwidths of patch antennas via way of the use of wide banding strategies. The techniques advanced for green wideband patch antenna layout have one or extra of the subsequent features: thick substrates of low permittivities are used; a scheme is devised to lessen the mismatch hassle related to thick substrates; with the aid of parasitic factors or slots, both new resonances are added near the principle resonance or current resonances are introduced near each other in order that an universal broader band reaction is received. [17-41]

According [26], the 4 techniques unique via way of a (stacked patches, aperture coupled patches, U -slot, L-probe) are likely the extra famous ones. Early papers on unmarried feed circularly polarized patch antennas are [24-25]. It changed into determined that the small disturbance on the preferred frequency need to be precisely the proper quantity to provide orthogonal polarizations with the identical amplitude, however 900 out of section. The axial bandwidth ratio is consequently extraordinarily slim, generally approximately 0.5%. Each feed excites a linearly polarized mode withinside the twin feed round patch antenna and the 2 modes are orthogonally polarized. A feeding community is designed to offer the 2 ports with the identical amplitude however section quadrature excitation. Achievable bandwidth of approximately 10% at the same time as retaining a skinny substrate. <3>

The proposed antenna configurations in Figure 1a, growing the bandwidth of microstrip patch antennas as massive as 5 instances a unmarried square patch is received at the same time as in Figure 1b; a huge working bandwidth for a unmarried-layer coaxially fed received via way of reducing a U-formed slot at the patch. This antenna shape with a thick substrate of $0.08\lambda_0$; has supplied impedance bandwidths of 10% to 40% and excessive go polarization in E aircraft.

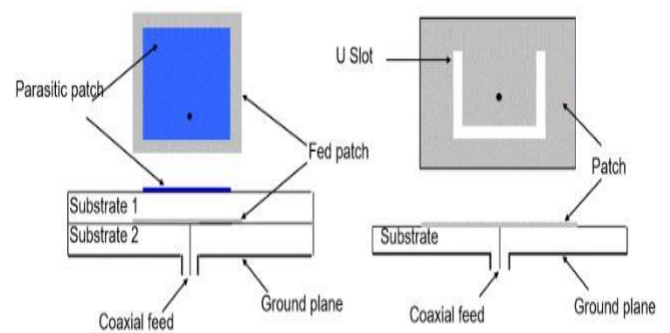

Fig. 1: Coaxial Fed Patches with Parasitics or Slot [17, 22] (a) Stacked Parasitic Patch (double-layer), (b) U-Shaped Slot (Single-Layer)

The configuration depicted in Figure 2 above, is well right for monolithic phased arrays, in which lively devices can be included on, no radiation from the feed network can intervene with the number one radiation pattern because of the truth a ground plane separates the two mechanisms.

The bandwidth finished is ready about 10% for non-resonant slot at the same time as about 20% resonant slot with immoderate decrease returned lobe radiation. While withinside the characteristic motion of the resonators of severa layers produces a considerably more potent bandwidth about (50-60%) achievable.

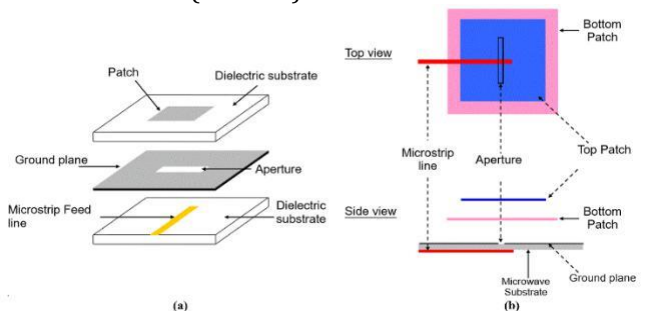

Fig. 2: Aperture Coupled Patches [19-20] (a) Non Resonant Slot, (b) Resonant Slot

Figure 3 suggests the horizontal arm of the probe offers a 2nd resonance along with the patch. It additionally presents the capacity to counteract the response of the probe. This patch has most effective one layer and one patch. The normal bandwidth for foam/air substrates is ready 30 %.

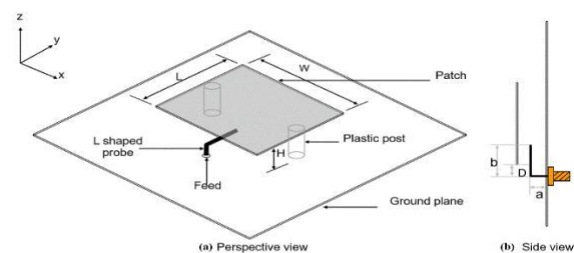

Fig. 3: L-Probe Fed Patch Antenna [12] (a) Perspective View, (b) Side View

As proven in Figure 4, the small disturbance on the preferred frequency needs to be precisely the proper quantity to supply orthogonal polarizations with the equal amplitude however 90 out of phase. The axial bandwidth ratio is consequently extraordinarily narrow, generally approximately 0.5%.

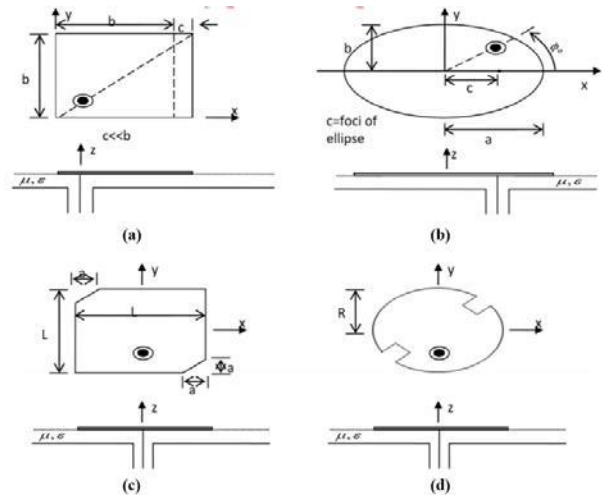

Fig. 4: Single-Feed Circularly Polarized Patch Antennas [28] (a) Almost Square Patch, (b) Almost Circular

(Elliptical Patch), (c) Square Patch with Truncated Corners, (d) Circular Patch with Indentations

As proven in Figure 5, It is located The incorporation of a U- slot withinside the patch can offer a flat enter resistance and a linear enter response throughout a much broader bandwidth than the traditional patch antenna The impedance matching frequency of the antenna may be various through putting a variable capacitor and an inductor on the enter of the antenna. It is appropriate to be used in lowering the crosstalk from adjoining channels in multichannel system.

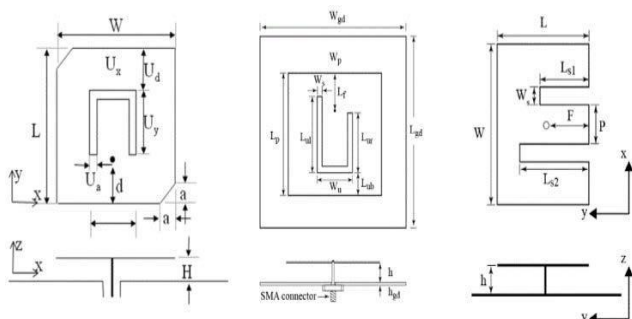

Fig. 5: Three Relatively Wideband Single Feed CP Patch Antennas [29-30] (a) U-Slot in a Square Patch, (b) Square Patch with, (c) Modified E-Patch with Truncated Corners Asymmetrical

Figure 6. Orthogonal polarization is found in each modes. A feeding community is designed to offer the 2 ports with the identical amplitude however section

quadrature excitation. A bandwidth of about 10 percentage even as preserving a skinny substrate (<3>

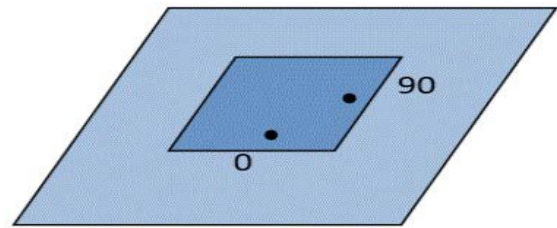

Fig. 6: Dual Feed CP Patch Antenna [28]

Figure 7. Elements are turned around in area and fed with section shifts. Radiation from better order mode has a tendency to be decreased due to symmetry, this uniquely fashioned array has the functionality of producing splendid round polarization (CP) over a notably huge frequency bandwidth and ensuing in desirable cross-polarization.

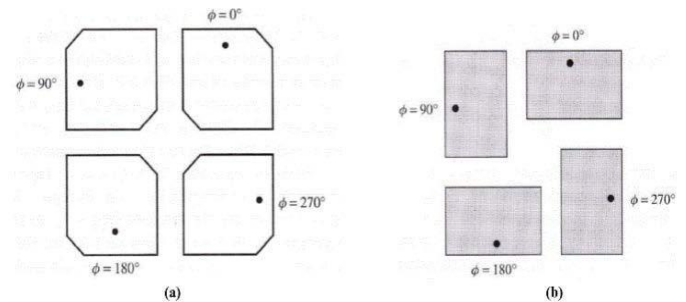

Fig. 7: Sequentially Rotated CP Subarray 2x2 CP Subarray with Sequential Rotation [28, 31] (a) Each Element is a CP Patch, (b) Each Element is a LP Patch

Figure 8. The length of the patch may be decreased via way of means of the use of excessive dielectric constant. However, the ensuing patch antenna can have slim impedance bandwidth. This motivates the look for different length discount methods. [42-47] via way of means of setting a shorting wall alongside the null withinside the electric powered discipline throughout the middle of the patch, the resonant duration may be decreased via way of means of a issue of two. The vicinity occupied via way of means of the patch may be decreased via way of means of a issue of 4 if the component ratio is stored the same. Fig. 8: Size Reduction Techniques [42-47]

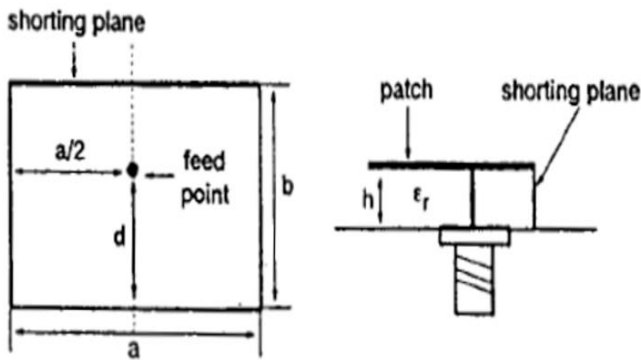

Fig. 8: Size Reduction Techniques [42-47]

3. Frequency Range

Microstrip patch antenna were broadly used when you consider that ultimate 50 years in numerous beneficial programs withinside the discipline of communication [29]. And consequently many programs cowl the wide variety of frequencies more or less from (100MHz to 100GHz). Various issue determines the sensible variety of running frequencies over which an antenna can operate.

The bodily houses of the antenna (length and weight) are frequently the restricting elements at decrease frequencies, at the same time as mechanical tolerances and electric losses frequently dominate antenna designs at better frequencies. The antenna shape is proven in Figure (9) (a) Microstrip antenna encompass a totally thin (zero $t \ll \lambda_0$, in which λ_0 is the free-area wavelength), steel strip (patch) positioned a small fraction of a wavelength $h \ll \lambda_0$, commonly $0.003\lambda_0 \leq h \leq 0.05\lambda_0$ above a floor plane. [29].

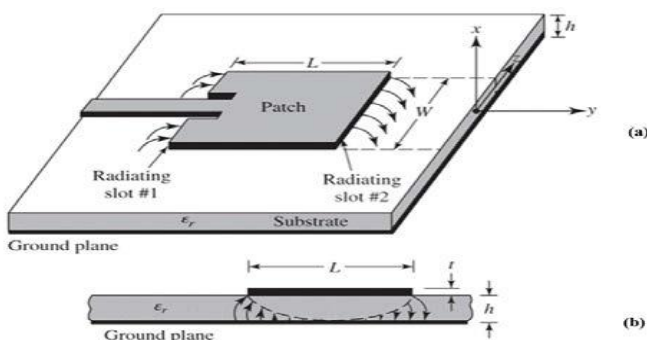

Fig. 9: Microstrip Antenna Structure from [29] (a) Microstrip Antenna, (b) Side View

The most graph of the patch is traditional to the patch (broadside radiator). For an oblong patch, represents the length of the patch that typically $\lambda_0/3 < L$

The measured -10dB information measure for this antenna is 4.92 Gc which covers channels a pair of and three of sixty GHz WLAN/ WPAN applications. Figure 10; It shown at the operational frequency of 457 megacycle and 471 MHz, the S11 measured results are -12.325 sound unit

and - 9.536 dB respectively. The designed prototypes at the same time enhance the gain (14 dB), bandwidth (BW) (12.84% of the operating central frequency) and potency (94%) of antenna and tested at X-band (8–12GHz) and 60GHz band (57–66 GHz) frequencies [94].

A frequency of 450 MHz is the bottom posted frequency for which microstrip patch antenna has been designed and fabricated [93]. The MPA has amazing sign propagation characteristics, which lead them to and ideal picks for rural verbal exchange networks. The patch antennas layout has been efficaciously evolved with unknown dielectric value. Is as proven in Figure 10.

The maximum posted frequency for microstrip patch antenna is presently 60 GHz [94] wherein the patch antenna dimensions are acquired through the scale extension technique wherein the antenna is exited with one in every of its better order TEM modes whose attributes are carefully matched with the essential mode [94], wherein array antenna has A measurement of (5.54mm x 4.44mm x 0.127mm) become etched on a low loss PCB substrate the usage of symmetrical square slits which can be carved at the patch aspect in Figure 11.

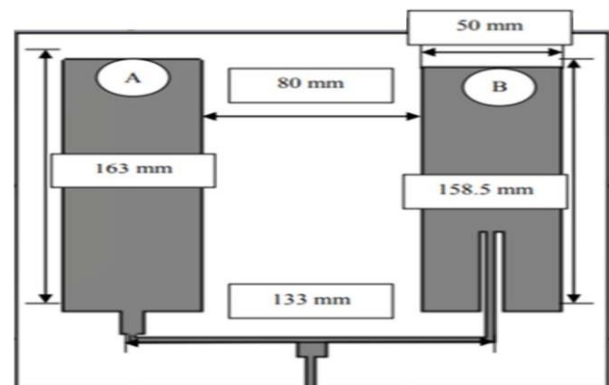

Fig. 10: The Lower Frequency Published Design (457MHz and 71MHz) for MPA [93]

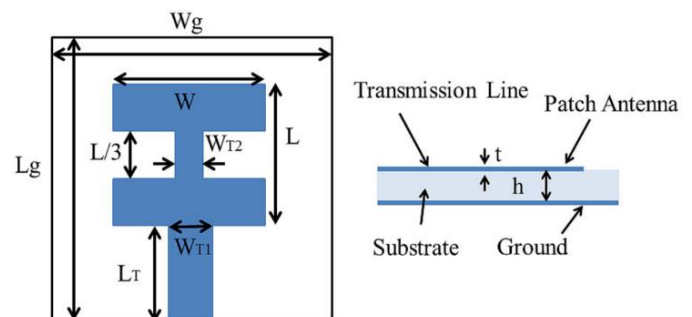

Fig. 11: The Highest-Frequency Published Design (60GHz) for MPA [80]

4. COMPACT MICROSTRIP PATCH ANTENNAS

In latest years, wi-fi communications have advanced very hastily and lots of cell gadgets are getting smaller and smaller. Compact antennas are required to fulfill the

miniaturization requirement. Many applications, in particular for patron wi-fi applications, require the combination of compact antennas in small programs including hand held laptop and clever telephones or different transportable device.

For compact and broadband patch antenna design, quite a few broadband strategies had been advanced the use of the 3 processes Q reduction, impedance matching and a couple of resonances. It is understood that the primary elements affecting the bandwidth of a microstrip patch antenna are the form of the radiator, the feeding scheme, the substrate and the association of radiating and parasitic elements.

This segment examines a few strategies for designing a compact MPA to enhance the overall performance of various researchers. A easy method utilized by researchers is the grades of slots or patch or floor cuttings. There is some of antennas the use of this method due to the fact slots of various shapes have an effect on the modern-day paths at the patch and bring about exclusive modes on the resonant frequencies. [48-58].

Figure 12 confirmed that it's far feasible to apply the proposed FSS shape as a forestall bands filter. The proposed FSS turned into then carried out to a traditional patch antenna as a excellentb price to enhance its advantage and efficiency.

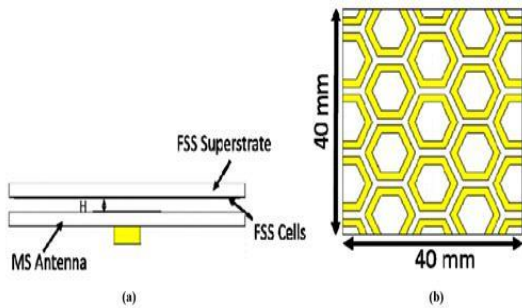

Fig. 12: Compact MPA with FSS Cell [54] (a) Top View, (b) Side Views

5. Wideband Designs

Many current and rising wi-fi applications, in addition to many radar applications, function over huge frequency bands, and therefore require broadband antennas. Some researchers international started to paintings to conquer the inherent downside of the slender bandwidth of impedance and produced exciting resultsSome works regarding broadband, multiband antennas, compact designs, round polarization, elevated directional designs, reconfigurable designs and array layout are supplied on this section. The frequency of operation wherein the antenna resonates had been additionally analyzed. The

comparative evaluation changed into proven in Table 1 – Table 3.

Figure 13; on this method one begins offevolved with a broadband, patch antenna, that could include one or extra patches. When a U-slot is reduce in one of the patches, a notch is added into the matching band, and the antenna will become a twin- band antenna. If some other U-slot is reduce withinside the equal patch or in some other patch, a triple-band antenna results.

When a U- slot is reduce into one of the patches, a droop withinside the matching band is inserted and the antenna will become a twin-band antenna. If some other U- slot is reduce withinside the equal patch or some other patch, the end result is a triple antenna. The styles and profits of the twin and triple band antennas are determined to be just like the unique broadband antenna. Because the band notches added with the aid of using the U- slots arise with out slots withinside the bandwidth of the antenna.

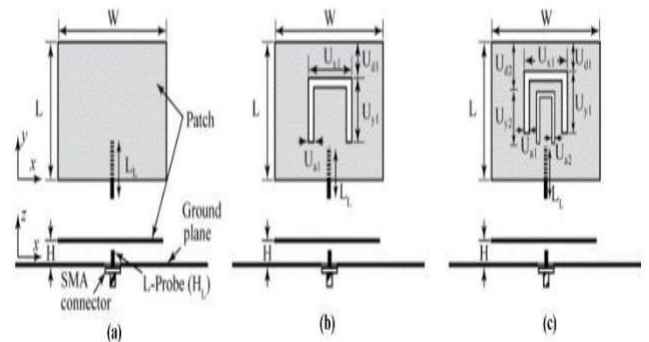

Fig. 13: Use of U-Slots to Introduce Band Notches in a Broadband Antenna [102]

Figure 14. The PASS concept was used to design an antenna with a sense of polarization that can be switched between RHCP and LHCP. PASS designs with versatile functionality have great potential for different wireless communication systems, such as GPS and WLANs

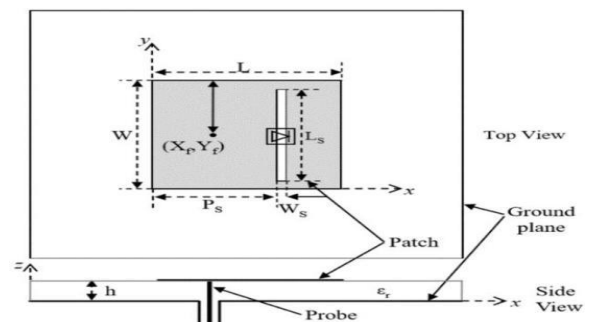
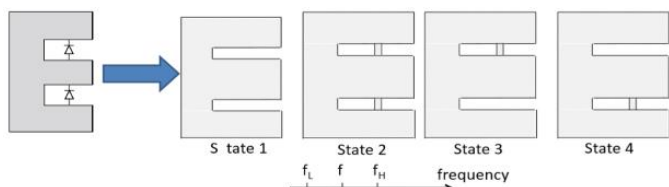

Fig. 14: Patch Antenna with Switchable Slot (PASS) [103]

Figure 15. This communique proposes a polarization reconfigurable E- fashioned patch antenna with wideband performance. The antenna can transfer its polarization from round right- hand polarization (RHC P) to round left-hand polarization(LHCP) and vice versa. The antenna radiation symmetry is maintained while the 2 round polarization modes are switched [104-105].



State	Switch 1	Switch 2	Frequency	Polarization
1	OFF	OFF	f_L	LP
2	ON	ON	f_H	LP
3	ON	OFF	f	LHCP
4	OFF	ON	f	RHCP

Illustrating four states of polarization

Fig. 15: Polarization Reconfigurable Modified E Patch; Illustrating Four States of Polarization [104-105]

MSA Shape	Center Frequency (fc) GHz	Feed Type	Dielectric Constant (ϵ_r)	Maximum Dimension (mm)	Gain (dBi)	BW (GHz)	Ref.
Rectangular	10.15	Slot	4.3	20 x 20 x 1.6	4.09	0.575	[48]
Elliptical	28	Inserted	4.4	5 x 5 x 1.6	N/A	4.6	[49]
Slot	28.2	Slot	3	29.9 x 28.7 x 0.13	9	1.38	[50]
Triangular Shaped	10	slot	4.4	20 x 18	3.19	5.8	[51]
T-Shape Slot	10/28/38	Slot	2.2	20 x 16.5 x 38	5.67/9.33/9.57	N/A	[52]
Diamond Shape	5.4	Inserted slot	3.6	14.04 x 17.86 x 0.762	9.2	1.4	[53]
FSS Unit (Hexagonal)	10	FSS unit	2.2	11.85 x 9.13	9.2	4	[54]
Rectangular	24.25 & 38	Inserted Slot	2.2	6.3 x 6.0 x 0.787	7.23 & 3.69	N/A	[55]
Quad Staircase Shaped MPA	2.44/5.33/7.79/9.39	Coaxial	2.2	4.35 x 49.4 x 1.6	6.49/6.05/9.98/8.55	0.06/0.34/0.28/0.78	[56]
Rectangular Slots	2-12	Inserted Slot	2.2	22 x 27	5 - 26.5	1.1	[57]
Multilayer Yagi	24		3.48	13 x 25.1 x 0.762	15.51	6.9	[58]

Table 1: Compact MPA designs

Figure sixteen to Figure 19 shows some distinctive enhancement strategies that improve the inherent problem of benefit and bandwidth in microstrip antennas at excessive frequency. With connection with Table 2 and 3, all of the antenna designs may be carried out in radio, television, 5G cellular cell communications. Among the diverse antenna designs, the symmetrical square antenna slits, the patch arrays antenna and the Pharaonic broadband antenna ankh-key offers the pleasant operation.

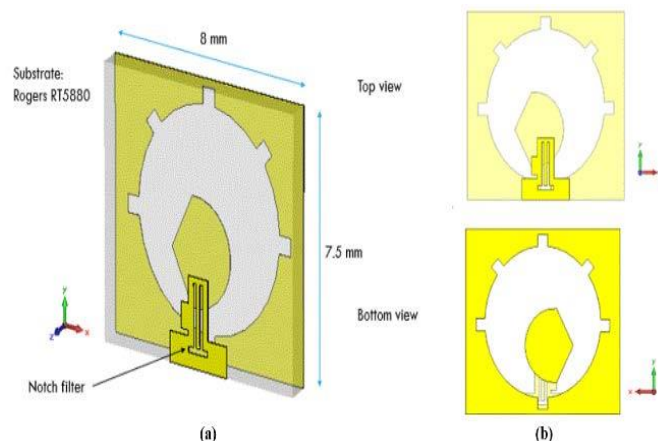

Fig. 16: An Example of Geometry and Dimensions of the Proposed Dual-Band 5G Antenna (a) 3D View, (b) Top and Bottom Views: $f_c = 28/38$ GHz, Gain = 4.2/6.9dB; R = -29dB; VSWR= from [79]

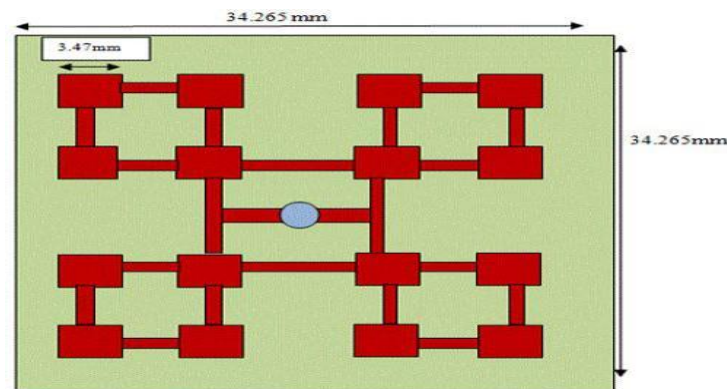

Fig. 17: An Example of 16 Element Antenna Cooperative Array $f_c = 28.5/35$, $B_w = 0.112/1.2121$; Gain = 14.82/10.09; R = -21.7/26dB from [81]

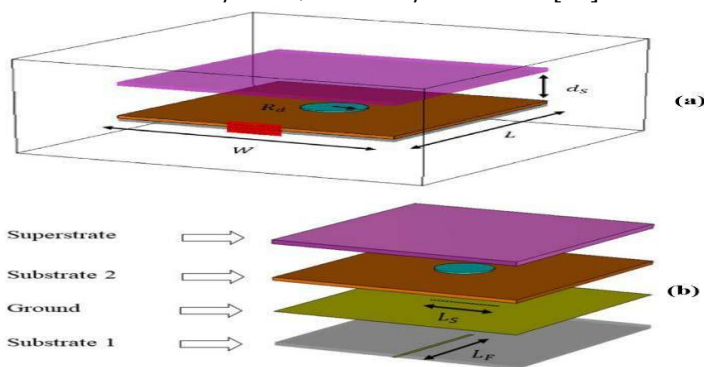

Fig. 18: An Example of Dual Band Antenna (a) Dimension of Patch Antenna, (b) Side View of Antenna: $f_c = 28/38$, Gain = 5.5/4.5dB; R = -40dB from [79]

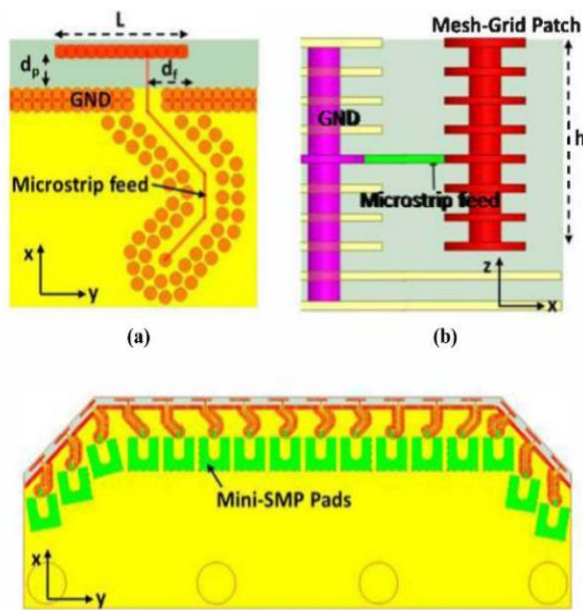

Fig. 19: Sample Graph with Blue (Dotted), Green (Solid) and Red (Dashed) Lines (a) Subfigure 1, (b) Subfigure 2

Operation Frequency	Proposed Antenna	Dielectric Constant (ε _r)	Technique Applied	BW @ (-10dB) (GHz)	Gain (dBi)	Ref.
28	2 x 2 U-shaped Patch Array Antenna	2.2	Inserted Slot	3.35	12	[82]
28	U-shaped MSA	3.36	Inserted Slot	-	4.15	[83]
28	Broadside Array MSA	2.2	Series-fed	0.5	15.4	[84]
28/32	4 x 1 - Elements Patch Array	4.35	Inserted	-	11.2	[85]
28	32- Elements Patch Array	2.2	Inserted	1.12	21.1	[86]
28	8-Elements Helix Phase Array Antenna	1	Inserted Slot	7	5	[87]
28	Parasitic Element MSA	4.4	Coplanar slot	1.55	6.7289	[88]
28	Swarm Intelligence Algorithm MSA	2.2	PSACO	0.35	10.49	[89]
28	Patch Phase Array Antenna	2.2	Inserted	1.4	8.64	[90]
28	PIFA	2.2	Slot & shorting strips	1.5	4.5	[91]
28	Empty Substrate Integrated Waveguide-fed square MSA	3.55	Aperture-couple	2.9	11.6	[92]
28	4x2 element microstrip antenna array patch	2.2	Probe feed	0.84	16.1	[93]

Table 3: Comparatives Analysis of different Feed echanism for 5G Applications System at 28GHz

VI. Summary and Conclusion

In engineering, the subject of the antenna has loved a really fruitful length in the course of the beyond numerous decades. Responsible for its accomplishment has been the technical advances in sure novel antennas, for instance, millimeter-wave antenna, broadband, dual/multi- band or reconfigurable structure, size-reduction, compact, low-profile, impedance bandwidth, excessive benefit or linear and round polarization programs., and the like. An full-size affect withinside the victory of radiating factors has been the improvements in 5G technology. Even alevn though a assured degree of adulthood has been accomplished, there are numerous troubles to be labored out. The modern miniaturized footprint appropriate for 5G programs machine along side greater overall performance traits is still now a maximum tough problem. However, the microstrip patch antenna may be designed to incorporated with an awful lot structure to expand styles for the modern and destiny 5G programs machine. Utilizing novel substances and new fabrication strategies for the antennas constitute every other method to provide a couple of potentialities for the machine overall performance. This will make the MPAs at mm-wave a fair greater possible opportunity to the traditional low-benefit resonant antenna.

REFERENCES

- [1] Benjebbour et al.: "5G Radio Access Technology," NTT DOCOMO Technical Journal, Vol.17, No.4, pp.16-28, Apr. 2016.
- [2] K.-L. Wong, Compact and Broadband Microstrip Antennas, John Wiley & Sons, New York, 2002.
- [3] Z. N. Chen and M. Y. W. Chia, Broadband Planar Antennas Design and Applications, John Wiley & Sons, Chichester, UK, 2006.

MPA Type	f _c (GHz)	Material for design	ε _r	Dimension (mm)	BW (GHz)	Gain (dBi)	Return loss (dB)	Ref.
Dual-Band Printed Slot Antenna.	28/38	RT Duroid	2.2	8 x 7.5	N/A	4.2/6.9	-40	[59]
Dual-Polarized Patch Array	28.5	FR4 substrate	2.2	11.6x 11.6	1.5-2	10	-20	[60]
A Grid Array Antenna	28	FR4 substrate	2.2	15 x 15	2.2	12.66	N/A	[61]
Mesh-Grid Antenna Array	28	10-layer FR4 PCB	4.2	N/A	>3	10.9	N/A	[62]
Wide Scanning Angle Phased Array	28	10-layer FR4 substrate	4.2	N/A	0.5	N/A	<10	[63]
A Compact Millimeter-Wave Slot Antenna Array (4 X 4)	28	single layer PCB	4.2	29.9x28.7	0.7	13	N/A	[64]
Antipodal Tapered Slot Antenna (Atsas)	28.5	Rogers substrate (5880)	2.2	25 x 30	1.42	12.2	N/A	[65]
A Switched Beam Planar Array	28	Rogers substrate (5880)	2.2	N/A	1	12	<10	[66]
Conformal Tapered Slot Antenna Array	24-40	FR4 substrate	2.2	65 x 130	14.8	>20	N/A	[67]
Circular-Shaped DD Patch Antenna Arrays	24	Dense Dielectric (DD)	N/A	3.2 x 3.3 x 2.2	N/A	16	<10	[68]
Microstrip Antenna Array 64-Elements	2.2	Rogers substrate (5880)	2.2		2	12		[69]
Dense Dielectric Patch Array Antenna.	28	RT Duroid	2.2	N/A	2.4	12.48	-29	[70]
Magneto Electric Dipole Leaky-Wave Antenna	28-32	RT Duroid	2.2	N/A	N/A	16.55	-25	[71]
Planar Antenna	22-40	PET	3.2	N/A	N/A	8.2	-18	[72]
Pharaonic Ankh-Key Broadband Antenna	60- 72	RT Duroid	2.2	7.5 x 7.5	N/A	8.4	-20.2	[73]
New Gridded Parasitic Patch Stacked Micro Strip Antenna.	60	Taconic TLY	2.2	N/A	15.6	8.6	-10	[74]
Patch Antenna Array	57/60	Liquid Crystal Polymer	2.9	55 x 70	N/A	16.7/17.1	-20/-20	[75]
Single Band Antenna	59.93	RT Duroid	2.2	8 x 8	4.028	5.48	-40	[76]
Double F Slot Patch Antenna.	58.10	Silicon	11.9	0.984 x 0.62	N/A	5.99	-32.5	[77]
Microstrip Antenna Array	38	RT Duroid	2.2	2.5 x 2.25		8	-40	[78]
Dual Band Antenna	22.25/38	RT Duroid	2.2	4.9 x 7.6	1.5 - 2	5.5/4.5	-40	[79]
Printed Patch Antenna Array.	37	RT Duroid	2.2	30.25 x 9.5	N/A	13.8	-17	[80]
16 Element Array Of Microstrip Patch Antenna	28.5/33	RT Duroid	2.2	34.265 x 34.265	0.1126/1.2121	14.82/10.09	-21.7/-26	[81]

Table 2: Bandwidths Achieved by MPAs for Wideband Application (f_c is the Centre frequency, ε_r

- [4] G. Deschamps and W. Sichak, "Microstrip Microwave Antennas," Proc. of Third Symp. On USAF Antenna Research and Development Program, October 18-22, 1953.
- [5] H. Gutton and G. Baissinot, "Flat aerial for ultra-high frequencies," French Patent no. 703 113, 1955.
- [6] Stone, W. R. (1994). Classified Ads Available in Magazine. IEEE Antennas and Propagation Magazine, 36(1), 37.
- [7] R. E. Munson, "Microstrip Phased Array Antennas," Proc. of Twenty-Second Symp. On USAF Antenna Research and Development Program, October 1972.
- [8] E.V Byron, "A new Flush Mounted Antenna Element for Phased Array Applications", Proc. Phased Array Antenna Symp., pp.187-192, 1970.
- [9] R. E. Munson, "Conformal microstrip antennas and microstrip phase arrays," IEEE Trans. Antennas and Propagation, vol. AP-22, no. 1, pp. 74-77, Jan. 1974.
- [10] J. Bahl and P. Bhartia, Microstrip Antennas, Artech House, 1980.
- [11] J. R. James, P. S. Hall and C. Wood, Microstrip Antenna Theory and Design, Peter Peregrinus, 1981.
- [12] IEEE Transactions on Antennas and Propagation, January 1981 Special Issue.
- [13] Derneryd, AA theoretical investigation of the rectangular microstrip antenna element. IEEE Transactions on Antennas and Propagation, 26(4), 532-535, 1978.
- [14] Pues, H., & Van de Capelle, A. (1984, December). Accurate transmission-line model for the rectangular microstrip antenna. In IEE Proceedings H-Microwaves, Optics and Antennas (Vol. 131, No. 6, pp. 334-340). IET.
- [15] Lo, Y. T., Solomon, D., & Richards, W. (1979). Theory and experiment on microstrip antennas. IEEE transactions on Antennas and Propagation, 27(2), 137-145.
- [16] Lo, Y. T., Richards, W. F., & Harrison, D. D. (1979). An Improved Theory for Microstrip Antennas and Applications. Part i (no. uiem-78-18-pt-1). Illinois University at urbana-champaign electromagnetics lab.
- [17] P. S. Hall, "Probe compensation in thick microstrip patches," Electron. Lett., Vol. 23, no. 11, pp. 606-607 1987.
- [18] G. Kumar and K. C. Gupta, "Broadband microstrip antennas using additional resonators gap coupled to radiating edges," IEEE Trans. Antennas and Propagation, Vol. AP-32, pp. 1375-1379, 1984.
- [19] R. Q. Lee, K. F. Lee, and J. Bobinchak, "Characteristics of a two-layer electromagnetically coupled rectangular patch antenna," Electron. Lett., Vol. 23, No. 20, pp. 1070-1073, 1987. Received: 25 June 2019/Accepted: 02 July 2019/Jour of Adv Research in Dynamical & Control Systems, Vol. 11, 07-Special Issue, 2019
- [20] S. D. Targonski, R. B. Waterhouse, and D. m. Pozar, "Design of wide-band aperture stacked patch microstrip antennas," IEEE Trans. Antennas Propagation, Vol. 46, No. 9, pp. 1245- 1251, 1998.
- [21] T. Huynh and K. F. Lee, "Single-layer single-patch wideband microstrip antenna," Electron. Lett., Vol. 31, No. 16, pp. 1310-1312, 1995.
- [22] S. Weigand, G. H. Huff, K. H. Pan, and J. T. Bernhard, "Analysis and design of broad-band single-layer rectangular U-slot microstrip patch antenna," IEEE Trans. Antennas Propagation, Vol. 51, No. 3, pp. 457-468, 2003.
- [23] F. Yang, Z. Z. Zhang, Z. Ye and Y. Rami-Samii, "Wide-band E-shaped patch antennas for wireless communications," IEEE Trans. Antennas and Propagation, Vo. 49, No. 7, pp. 1049- 1100, 2001.
- [24] S. A. Long, L. C. Shen, D. H. Schaubert, R. G. Farrar, "An experimental study of the circular-polarized elliptical printed-circuit antenna," IEEE Trans. Antennas and Propagation, Vol. AP-29, No. 1, pp. 95-99, 1981.
- [25] W. F. Richards, Y. T. Lo, D. D. Harrison, "An improved theory for microstrip antennas and applications," IEEE Tran. A&P, Vol. 29, pp. 137-145, 1979.
- [26] P. S. Hall, "Probe compensation in thick microstrip patches," Electron. Lett., Vol. 23, no. 11, pp. 606-607 1987. P.S. Hall, "Application of sequential feeding to wide bandwidth circularly polarized microstrip patch arrays," IEE Proc. Vol.136H, no.5, pp.390-398, Oct 1989.
- [27] S.L.S. Yang, A.A. Kishk, K.F. Lee, "Frequency Reconfigurable U-slot Microstrip Patch Antenna," IEEE AWPL, vol. 7, pp. 127-129, 2008.
- [28] A. Khidre, K. F. Lee, F. Yang and A. Z. Elsherbeni, "Circular polarization reconfigurable wideband E-shaped patch antenna for wireless applications, IEEE Trans. AP Vol. 61, No. 2, pp. 960-964, 2013.
- [29] S.H. Chen, J. S. Row, K. L. Wong, "Reconfigurable square-ring patch antenna with pattern diversity," IEEE Trans. A&P, vol 55, pp.472-475, 2007.
- [30] J. Huang, "A technique for an array to generate circular polarization with linearly polarized elements," IEEE Trans. AP, vol. 34, pp. 1113-1124, 1986.
- [31] The Analysis and Design of Microstrip Antennas and Arrays David M. Pozar, Daniel 1992.
- [32] Yunusa Rabi, Magaji1, Yakubu Yunusa Sulaiman, Muhammed Mahmud Babangid, improved design of compact microstrip patch antenna for future 5G applications. International
- [33] Schaubert, D., Farrar, F., Sindoris, A., & Hayes, S. (1981). Microstrip antennas with frequency agility and polarization diversity. IEEE Transactions on Antennas and Propagation, 29(1), 118-123.
- [34] Zhong, S. S., & Lo, Y. T. (1983). Single-element rectangular microstrip antenna for dual-frequency operation. Electronics Letters, 19, 298-300.
- [35] Deshmukh, A. A., & Ray, K. P. (2010). Multi-band configurations of stub-loaded slotted rectangular microstrip antennas. IEEE Antennas and Propagation Magazine, 52(1), 89-103.
- [36] Davidson, S. E., Long, S. A., & Richards, W. F. (1985). Dual-band microstrip antennas with monolithic reactive loading. Electronics Letters, 21(20), 936-937.
- [37] Brocker, D. E., Werner, D. H., & Werner, P. L. (2014, July). Dual-band shorted patch antenna with significant size reduction using a meander slot. In Antennas and Propagation Society International Symposium (APSURSI), 2014 IEEE (pp. 289-290). IEEE.
- [38] Picher, C., Anguera, J., Cabedo, A., Puente, C., & Kahng, S. (2009). Multiband handset antenna using slots on the ground plane: Considerations to facilitate the

- integration of the feeding transmission line. *Progress in Electromagnetics Research*, 7, 95-109.
- [39] Hori, T. (2005). Broadband/multiband printed antennas. *IEICE transactions on communications*, 88(5), 1809-1817.
- [40] Pinhas, S., & Shtrikman, S. (1988). Comparison between computed and measured bandwidth of quarter-wave microstrip radiators. *IEEE Transactions on Antennas and Propagation*, 36(11), 1615-1616.
- [41] Li, R., DeJean, G., Tentzeris, M. M., & Laskar, J. (2004). Development and analysis of a folded shorted-patch antenna with reduced size. *IEEE Transactions on Antennas and Propagation*, 52(2), 555-562.
- [42] Chiu, C. Y., Shum, K. M., Chan, C. H., & Luk, K. M. (2003). Bandwidth enhancement technique for quarter-wave patch antennas. *IEEE Antennas and wireless propagation letters*, 2(1), 13
- [43] Luk, K. M., Chair, R., & Lee, K. F. (1998). Small rectangular patch antenna. *Electronics Letters*, 34(25), 2366-2367.
- [44] Wong, H., Luk, K. M., Chan, C. H., Xue, Q., So, K. K., & Lai, H. W. (2012). Small antennas in wireless communications. *Proceedings of the IEEE*, 100(7), 2109-2121.
- [45] Khan, M. U., Sharawi, M. S., & Mittra, R. (2015). Microstrip patch antenna miniaturisation techniques: a review. *IET Microwaves, Antennas & Propagation*, 9(9), 913-922.
- [46] Yunusa Rabi, Magaji, Yakubu Yunusa Sulaiman, Muhammed Mahmud Babangid, improved design of compact microstrip patch antenna for future 5G applications.
- [47] N Kumar Reddy, Asish Hazra, Vinod Sukhadeve, A Compact Elliptical Microstrip Patch Antenna for Future 5G Mobile Wireless Communication. *Applied Sciences*, 2017, 1 (1).
- [48] Alreshaid, A., Hammi, O., Sharawi, M., & Sarabandi, K. (2015). A compact millimeter-wave slot antenna array for 5G standards. 2015 IEEE 4th Asia-Pacific Conference on Antennas and Propagation (APCAP).
- [49] M. A. Ullah, F. B. Ashraf, T. Alam, M. S. Alam, S. Kibria. A compact triangular shaped microstrip patch antenna with triangular slotted ground for UWB application. 2016 International Conference on Innovations in Science, Engineering and Technology, ICISSET 201
- [50] Abdelaziz, A., & Hamad, E. K. (2018). Design of a Compact High Gain Microstrip Patch Antenna for Tri-Band 5 G Wireless Communication. *Frequent*, 73(1-2), 45-52.
- [51] Chouhan, S., Gupta, M., & Panda, D. K. (2016, December). Designing of compact micro strip patch antenna with diamond structure and modified ground for isolation improvement. In *Recent Advances and Innovations in Engineering (ICRAIE)*, 2016 International Conference on IEEE. (pp. 1-5).
- [52] Mohamed AlyAboul-Dahab, Hussein Hamed Mahmoud Ghouz and Ahmed Zakaria Ahmed Zak. High gain compact microstrip patch antenna for x-band applications. *International Journal of Antennas (JANT)* Vol.2, No.1, January 2016
- [53] N. N. Daud, M. N. Osman, M.R. Kamarudin, A.R. Kram, M.M. Azizan. A compact antenna design for fifth generation wireless communication system. *MATEC Web of Conferences* 140, 01009 (2017) DOI: 10.1051/mateconf/201714001009 ICEESI 2017.
- [54] Chouhan, S., Gupta, M., & Panda, D. K. (2016, December). Designing of compact micro strip patch antenna with diamond structure and modified ground for isolation improvement. In *Recent Advances and Innovations in Engineering (ICRAIE)*, International Conference on (pp. 1-5). IEEE.
- [55] Afzal, W., Haq, M. A., & Khan, M. A. A Compact Microstrip Patch Antenna for Multiband Wireless Applications. *Proceedings of the 2nd International Conference on Engineering & Emerging Technologies (ICEET)*, Superior University, Lahore, PK, 26-27 March, 2015
- [56] Ramos, A., Varum, T., & Matos, J. (2018). Compact Multilayer Yagi-Uda Based Antenna for IoT/5G Sensors. *Sensors*, 18(9), 2914.
- [57] Dual-polarized Patch Array Antenna Package for 5G Communication Systems", 11th European Conference on Antennas and Propagation (EUCAP), On Software, Telecommunications and Computer Networks (SoftCOM).
- [58] Jin-Kyoung Du, Kwangsup So, Yun Ra, Seung-Yoon Jung, Jongmoon Kim, SeungYeon Kim, Seungmin Woo, Hong-Teuk Kim, Yo-Chuol Ho, and Woohyun Paik. "Dual-polarized Patch Array Antenna Package for 5G Communication Systems", 11th European Conference on Antennas and Propagation (EUCAP), 2017.
- [59] Chen, Z., & Zhang, Y. (2013). FR4 PCB Grid Array Antenna for Millimeter-Wave 5G Mobile Communications. *IEEE MTT-S International Microwave Workshop Series on*
- [60] Hong, W., Baek, K., Lee, Y., & Kim, Y. G. (2014, June). Design and analysis of a low-profile 28 GHz beam steering antenna solution for future 5G cellular applications. In *Microwave Symposium (IMS), 2014 IEEE MTT-S International* (pp. 1-4). IEEE.
- [61] Hong, W., Kwanghun Baek, Lee, Y., & Kim, Y. G. (2014). Design and Analysis of a Low-Profile 28 GHz Beam Steering Antenna Solution for Future 5G Cellular Applications. *IEEE MTT-S International Microwave Symposium (IMS2014)*.
- [62] Alreshaid, A., Hammi, O., Sharawi, M., & Sarabandi, K. (2015). A compact millimeter-wave slot antenna array for 5G standards. 2015 IEEE 4th Asia-Pacific Conference on Antennas and Propagation (APCAP).
- [63] Ashraf, M. A., Haraz, O. M., & Alshebeili, S. (2015). Compact size enhanced gain switched beam conformal antipodal tapered slot antenna system for 5G MIMO wireless communication. 2015 IEEE 11th International Conference on Wireless and Mobile Computing, Networking and Communications (WiMob).
- [64] Alreshaid, A., Hammi, O., Sharawi, M., & Sarabandi, K. (2015). A compact millimeter-wave slot antenna array for 5G standards. 2015 IEEE 4th Asia-Pacific Conference on Antennas and Propagation (APCAP).
- [65] Gampala, G., & Reddy, C. J. (2016). Design of millimeter wave antenna arrays for 5G cellular applications using FEKO. 2016 IEEE/ACES International Conference on Wireless Information Technology and Systems (ICWITS) and Applied Computational Electromagnetics (ACES).

- [67] Jang, K., Khattak, M. K., Jeon, J., Kim, H., & Kahng, S. (2015). Handheld beam forming antennas adoptable to 5G wireless connectivity. 2015 International Workshop on Antenna Technology (iWAT)
- [68] Chen, A., Zhang, Y., Chen, Z., & Yang, C. (2011). Development of a Ka -band & wideband circularly polarized 64-element microstrip antenna array with double application of the sequential rotation feeding technique. *IEEE antennas and wireless propagation letters*, 10, 1270-1273.
- [69] Osama m. haraz, Ayman elboushi, Saleh a. alshebeili and Abdel-raziksebak, "Dense Dielectric Patch Array Antenna with Improved Radiation Characteristics Using EBG Ground Structure and Dielectric Superstrate for Future 5G Cellular Networks", *The journal for rapid open access publishing*, Vol. 2,909-913, ISSN-2169-3536, August 2014.
- [70] Magneto electric Dipole Leaky-Wave Antenna for Millimeter Wave Application", *IEEE Transaction on Antenna and Propagation*, Vol. 65, No. 12, December 2017.
- [71] Syeda Fizzah Jilani, Akram Alomancy, "Planar Millimeter-Wave Antenna on Low-Cost Flexible PET Substrate for 5G Applications", 10th European Conference on Antennas and Propagation (EuCAP), June 2001.
- [72] Noha M. Rashad, W. Swelam, M. H. Abd El Azeem, "Pharaonic Ankh-Key Millimeter Wave Broadband Antenna Design and Fabrication for 5G Applications", *IEEE Transaction on Antenna and Propagation*, 2017.
- [73] Iskandar Fitri, Al Amin Akbar T "A New Gridded Parasitic Patch Stacked Microstrip Antenna for Enhanced Wide Bandwidth in 60 GHz Band", *IEEE Transaction on Antennas and Propagation*, 2017
- [74] Patrick Cabrol, Philip Pietraski, "60 GHz Patch Antenna Array on Low Cost Liquid-Crystal Polymer (LCP) Substrate", *Systems, Applications and Technology Conference (LISAT)*, June 2014.
- [75] Jyoti Saini, S. K. Agarwal "Design a Single Band Microstrip Patch Antenna at 60 GHz Millimeter Wave for 5G Application", *International Conference on Computer, Communications and Electronics (Comptelix)*, July 2017
- [76] Farhan Ahmad, Dr. BoutheinaTlili "Design and Analysis of Millimeter Wave Double F Slot Patch Antenna for future 5G Wireless Communications" *International Conference on Electrical and Computing Technologies and Applications (ICECTA)*, 2017.
- [77] Cheng-Nan Hu, Kevin Peng, "Design of a mm-Wave Microstrip Antenna Array", *Electromagnetics: Applications and Student Innovation Competition (iWEM)*, December 2015.
- [78] N. N. Daud, M. Jusoh, H. A. Rahim, R. R. Othman, T. Sapabathy, M. N. Osman, M. N. M. Yassin, M. R. Kamarudin, "A Dual Band Antenna Design for Future Millimeter Wave Wireless Communication at 24.25 GHz and 38 GHz", *IEEE 13th International Colloquium on Signal Processing & its Applications (CSPA)*, March 2017.
- [79] Rabbani, Muhammad; Ghafouri-Shiraz, Hooshang, Improvement of microstrip patch antenna and bandwidth at 60GHz and x bands for wireless applications. *IET Microwaves, Antennas and Propagation*, vol. 10, no. 11, pp. 1167-1173. DOI: 10.1049/iet-map.2015.0672.
- [80] Beenish, Tripti Saraswat, Malay Rajan Tripathy and Garima Mahendru "Design of a High Gain 16 Element Array of Microstrip Patch Antennas for Millimeter wave applications", *2nd International Conference on Contemporary Computing and Informatics (ic3i)*, 2016.
- [81] Nanae Yoon & Chulhun Seo; 28GHz Wideband 2 x 2 U-slot Patch Array Antenna. *Journal of Electromagnetic Engineering and Science*, Vol.17, No. 3, 133-137, July, 2017.ISSN 22348409.
- [82] Neha Kothari & Sunil Sharma; A 28-GHz U-slot Microstrip Patch Antenna for 5G Applications, *International Journal of Engineering Development and Research (www.ijedr.org)* 2018 IJEDR | Volume 6, Issue 1 | ISSN: 2321-9939.
- [83] Omar, A., Al-Saif, S., Ashraf, M. A., & Alshebeili, S. (2016, July). Design and analysis of millimeter wave series fed microstrip patch array for next generation wireless communication systems. In *Antenna Technology and Applied Electromagnetics (ANTEM)*, *IEEE 17th International Symposium on* (pp. 1-2)..
- [84] Mohammed Bakry El Mashade & E. A Hegaze; Design and Aanlysis of MSA Patch Array Antenna. *WSEAS Transaction on Communication*, E-ISSN: 2224-2864 Vol.17, 2017.
- [85] M. A. A Rahim, I. M. Ibrahim, R. A. A. Kamaruddin, Z Zakaria, N. Hassim; Characterization of Microstrip Patch Array Antenna at 28 GHz. *Centre for Telecommunication Research and Innovation, Faculty of Electronic and Computer Engineering Universiti Teknikal Malaysia Melaka, Hang Tuah Jaya, 76100 Durian Tunggal, Melaka, Malaysia*. e-ISSN: 2289-8131 Vol. 9 No. 2-8.
- [86] Igor Syrytsin, Shuai Zhang, and Gert Frolund Pedersen; Circular Polarized Planar Helix Phased Antenna Array for 5G Mobile Terminals.978-1-50904451-1/17 @2017 IEEE.