

SIMULATION AND ANALYSIS OF SPEED CONTROL OF ELECTRIC VEHICLE IN MATLAB/SIMULINK

Abhimanyu Mandal¹, Akash Dewangan², Shashank Tiwari³

¹Assistant Professor (EE), CCET Bhilai, Chhattisgarh, India

²Assistant Professor (EE), CCET Bhilai, Chhattisgarh, India

³Assistant Professor (EE), BIT Durg, Chhattisgarh, India

Abstract- Electric vehicles are a viable solution for lowering greenhouse gas emissions. Electric vehicles not only reduce fossil fuel dependency, but they also minimise ozone damaging compounds and support large-scale renewable deployment. Despite extensive research on the qualities and qualities of electric vehicles, as well as the nature of their charging infrastructure, electric car manufacturing and network modelling continue to evolve and be constrained. The study addresses the various modelling approaches used in studies of the market penetration rate of Electric Vehicles, Hybrid Electric Vehicles, Plug-in-Hybrid Electric Vehicles, and Battery Electric Vehicles. The study is unique in that it addresses crucial hurdles and insufficient charging facilities for a growing country like India. When renewable energy sources are unavailable, the development of the innovative Vehicle-to-Grid concept has provided an additional power source. We conclude that considering the unique characteristics of electric vehicles is critical in their development.

Key Words: Electric vehicle (EV), Battery electric vehicle (BEV), Hybrid electric vehicle (HEV), Battery

1. INTRODUCTION

Electric Vehicles (EVs) are becoming a promising conduit for improving air quality, energy security, and economic opportunity in India, thanks to the tremendous growth of the automobile sector. The Indian government recognises the need to investigate sustainable mobility options in order to reduce reliance on imported energy sources, reduce greenhouse gas emissions, and minimise the negative effects of transportation. Carbon dioxide emissions can be lowered by implementing preventative actions to avoid catastrophic climate change, which poses a threat to the planet's biodiversity. Major efforts have been made to reduce the use of fossil fuels in power generation, transportation propulsion, energy consumption, and carbon sequestration. Electric vehicles (EVs) could be a viable option for reducing carbon dioxide emissions. Though the use of EVs has begun, people are still depending upon fossil fuel powered vehicles. However, the EVs are facing challenges on life cycle. When compared to typical fossil-fueled vehicles, the LCA, charging,

and driving range are all superior. Electric vehicle manufacture emits 59 percent more CO₂ than conventional vehicle manufacture. On a tank-to-wheel basis, the ICEV emits 120 g/km of CO₂, however this rises to 170–180 g/km when viewed through the lens of the LCA. While electric vehicles emit no CO₂ from the point of origin to the point of use, they do emit CO₂ from the point of use to the point of use. The average CO₂ is estimated to be measured across a vehicle's life cycle rather than over a single vehicle. The total CO₂ emissions from a vehicle during its entire life cycle vary substantially depending on the power source used and how the vehicle is driven. Due to harmful emissions from the transportation sector and investments by various OEMs, there is concern about the growth of more and lower-cost EVs in the future. Several variables, including technology advancements, lower car costs, government policy support, vehicle purchasing incentives, parking benefits, and enough public charging infrastructure, may contribute to the proliferation of electric vehicles in India. Because electric vehicles are produced in such small quantities, their overall market share in India is insignificant. Electric vehicles (EVs) can be two-wheelers like electric bicycles and scooters, three-wheelers like E-rickshaws, or four-wheelers like electric cars. The Reva Electric Car, India's first electric car manufacturer, launched its car in the early 2000s with the goal of producing inexpensive cars using modern technology. Mahindra Electric Mobility Ltd, India's lone BEV producer, is the market leader. Toyota Kirloskar Motor Pvt. Limited, BMW AG, Volvo Car Corporation, and Honda Motors Co. Ltd. are other significant HEV manufacturers with operations in India. The Mahindra e2oPlus, Mahindra e-Verito, Mahindra e-KUV 100, Eddy Current Controls Love Bird, Atom Motors Stellar, and others were among the other models. The range type of these parameters is then used to compare them to one another. The effect of different charging methodologies for electric vehicles on the national grid, as well as storage utilisation model-based non-linear observers for predicting the torque of permanent magnet synchronous motors in hybrid electric vehicles. The maximum transmissible torque approach is determined in order to improve the torque control framework's antiskid execution and the stability of electric vehicles. In an electric vehicle's Li-ion battery management Issues such as battery cell voltage, battery state estimation (battery SOC, SOH, DOD, and SOF), and battery life estimation equalization and uniformity and fault analysis of the battery can provide motivation for the research and

design of the battery management system. Reviews of optimal management strategies, energy management systems, and electric vehicle modelling approaches were investigated. Electric vehicles can also communicate with the grid by charging and discharging. Grid-to-Vehicle (G2V), Vehicle-to-Grid (V2G), and Vehicle-to-Building (V2B) are three different ways to interact with the grid (V2B). The EV is charged from the grid in G2V, while it discharges power to the grid in V2G. The bi-directional flow of electrical energy between a vehicle and the electric grid can be controlled at regular intervals in V2G. The vehicle to grid system refers to the integration of electric vehicles into the electrical grid. Energy flows both to and from the vehicle in this area making it. The system architecture of EV includes mechanical structure, electrical and electronic transmission which supplies energy and information system to control the vehicle. The specific EV design considerations are listed below-

- I. Identifying the environment and market trend for EV.
- II. Determining all the technical specifications and estimation of load requirements for EV.
- III. Assessing the infrastructure required for designing and also including the recycling of batteries.
- IV. Defining the system requirements according to its configuration for various applications such as hybrid EV, battery EV, and fuel cell EV.
- V. Defining its energy supply for different cases such as generation or storage, single or hybrid.
- VI. Identifying the primary essential component of EV propulsion system consisting of a single or multiple motor, converter, transmission types and mounting methods.
- VII. Determining its driving range and calculating specific parameters named as speed, torque energy, and power density, etc.

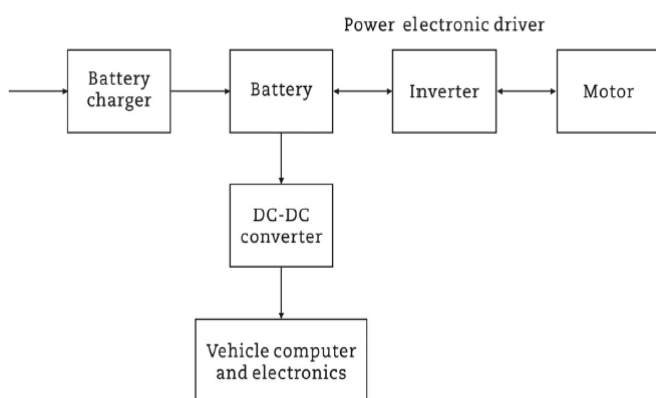

Fig-1: Key component of an electric vehicle

1.1 FACTORS AFFECTING THE EV

There are two types of factors that affect the adoption of EVs, i.e. internal factors and external factor

1.1.1 INTERNAL FACTORS

Electric vehicles have specific qualities, including as driving range, charging time, and cost, that make them less convenient in today's environment. EVs are more expensive than regular engine vehicles, with the cost of an EV being significantly higher than the cost of another typical vehicle. People were also unwilling to pay the hefty cost demanded by EVs, according to the study. Studies on the purchase price of EVs indicated that plug-in hybrid EVs (PHEV) and battery operated EVs (BEV) may be competitive with internal combustion engine vehicles (ICEV) in Germany by 2025. The significant decrease in the price of electric vehicles points to ongoing research into many parameters like as driving costs and buying prices. There is no plausible explanation for why the purchasing price dropped faster than the other EV models. More research is needed to link the cost of the vehicle's performance to its pricing. One of the major roadblocks for EVs is their limited driving range compared to regular vehicles. The most significant problem with EVs, according to 33% of consumers, is battery range. PHEVs might be preferable to BEVs. BEVs, on the other hand, are favoured above PHEVs due to improved charging infrastructure. The other big stumbling block in the adoption of EVs is charging time. Although, in comparison to the driving range, it may be less harsh. The majority of consumers believe it is a disadvantage, yet they are all willing to pay for rapid gratification.

1.1.2 EXTERNAL FACTORS

Consumer traits, fuel pricing, and the availability of charging stations are all external factors that may influence EV adoption. Fuel price increases are produced by the combustion of fossil fuels in automobiles' combustion engines. The adoption of electric vehicles has a direct impact on petroleum-fuel pricing. The cost of gasoline is not a significant factor in determining EV market share. Fuel prices are very important factor of HEV As consumers have different types of interest and the adoption of an EV depends on different consumer characteristics such as education, income, level of environmentalism, number or type of car owned and love for technology. Several studies found that consumers having higher education are more likely to consider. There is no evidence that more income makes people more inclined to use electric vehicles, according to the study. In reality, because of the driving range and other variables, it diminishes customer likelihood and makes EV adoption less likely. While pollution reduction is the most important aspect of EVs, it was also discovered that it is evaluated considerably less than performance indicators. The majority of people, according to the author, liked the drop in gasoline vehicles. The criteria that determine EV

market share within a country are not education or environmental awareness. Furthermore, research imply that electric vehicle technology needs to be developed in order for EVs to be more adaptable. The presence of charging stations plays an essential role in consumer adoption of EVs, as the limited availability of charging stations may hinder EV adoption.

2. COMPONENTS OF EVS

Electric vehicles rely on propulsion systems rather than internal combustion engines. The major components of an electric vehicle include motors, power electronic drivers, energy storage systems, charging systems, and DC-DC converters because it is powered by electricity.

2.1 MOTORS

Each motor has its own set of traits and benefits. Great power density, fast torque response, high efficiency over full speed and torque ranges, high robustness and strong dependability for many vehicle operating circumstances, and at a reasonable cost are all requirements of EV motors. Direct current (DC) variable drives were used to create all of the EVs. Because DC drives feature a commutator, they require less maintenance than conventional drives. However, we all know that DC motors are employed for low-power applications up to 4 kW, and that they require support and have a shorter lifespan. It is, nonetheless, appropriate for low-power applications such as an electric wheelchair or a microcar. As a result of the introduction of more beneficial alternating current (AC) drives, we are moving towards AC motors. Now, a new era has pushed for commutator-less motors, which has resulted in numerous benefits such as increased efficiency and high-power density at low operating costs, increased DC motor reliability, and reduced DC motor maintenance. As a result, AC motors of various sorts such as induction motors, DC brushless motors, permanent magnet synchronous motors, and switching reluctance motors are available. As we all know, the motor is the most important component of an electric vehicle, therefore choosing the right motor with the right rating is critical. Induction motors (IM) are utilised as commutator motors in electric vehicles (EVs) because they are more efficient. It is a widely used AC motor with a variable speed driving application, such as air conditioning, elevators or escalators, and many higher-powered electric vehicles (EVs) with more than 5 kW of energy. Without the use of an electronic controller, IM and Synchronous motors are traditionally used to feed a sinusoidal supply and produce constant instantaneous torque. When a field winding is replaced with a permanent magnet (PM), the synchronous motor becomes a PM synchronous motor (PMSM). The PM rotor was chosen because of its high kW and current ratings, which provide greater torque speed combined with lightweight commercial availability and compact dimension.

Surface-mounted and interior-mounted PM rotors are the two types of PM rotors. The magnets in the surface-mounted variant are located outside the motor, but the magnets in the inside type are located within the magnetic structure of the rotor. Because of its high operating speed, the internal model should be preferred. Because of its advantages, such as widening the speed range and improving efficiency, new motors, such as PM brushless motors, are now being employed to overcome the IM for EVs. Because there is no rotor in this case, there are no rotor copper losses. Motor efficiency, on the other hand, is intrinsically higher, and acceleration is also increased. A switching reluctance motor (SRM) is a synchronous device that runs on square wave unipolar current driven by an inverter. Because there is no PM, it is a variable reluctance machine with a fault tolerance capability. Its dependability also improves. Some researchers employed an SR motor in car traction, which could reduce the cost of the system while simultaneously improving its performance. SR motors are also being used in electric propulsion systems by a number of other researchers and firms.

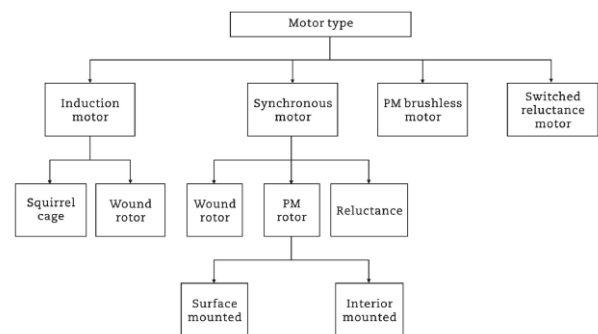

Fig -2: Various Motors Used In Electrical Vehicle

2.2 POWER ELECTRONIC DRIVER

In an electric propulsion system, power devices are the most important component. This system comprises of a power switching device with closed-loop control and a switching strategy for increasing the efficiency of our system. Power semiconductor devices have been employed in electric vehicles over the past 25 years. Thyristors were first employed as a power semiconductor switch in electric vehicle controllers in the 1970s. Researchers have since replaced thyristors with new power devices such as bipolar junction transistors (BJTs), metal oxide semiconductor field effect transistors (MOSFETs), gate turn-off thyristors (GTOs), insulated gate bipolar transistors (IGBTs), and others. However, choosing the right power device is essential, and this decision may be influenced by the needs of electric vehicles and the specifications of semiconductor devices. For electric propulsion vehicles, three types of semiconductor devices are commonly utilised. After examining the properties of all power devices, IGBTs are gaining traction for use in electric vehicles. IGBTs have several advantages over other devices, including superior conductivity to BJTs

and high-power density, high efficiency, compactness, and low cost of useable power. Every module has six thyristors, and the drive circuit is built into the single package.

2.3 ELECTROCHEMICAL ENERGY STORAGE SYSTEM (EESS)

The energy storage system that manages and regulates the flow of energy is given top priority in EVs. The primary focus is on energy storage and its fundamental properties such as storage capacity, energy storage density, and many others. Primary battery, secondary battery, super capacitor, fuel cell, and hybrid energy storage systems all require some form of energy conversion process. This type of classification can be applied to a variety of domains, and the analysis can be abstracted depending on the application. The electrochemical ESS, such as batteries, super capacitors, and fuel cells, is a high priority for electric vehicle applications. Electrochemistry, or the shifting of electrons through chemical processes at the electrode-electrolyte interface, is the subject of an electro-chemical system. Primary and secondary batteries, super capacitors, fuel cells, electrolyzers, and a variety of other energy storage systems based on electrochemistry have all been developed.

- I. Zinc-Carbon and alkaline manganese dioxide batteries
- II. Zinc-air battery
- III. Silver-oxide battery
- IV. Magnesium/manganese dioxide battery
- V. Lithium primary battery
- VI. Lithium-sulfur dioxide battery
- VII. Lithium-thionyl chloride battery
- VIII. Lithium-manganese dioxide battery
- IX. Lead-acid battery
- X. Lithium-ion battery
- XI. Lithium-sulfur and lithium-air batteries
- XII. Nickel-metal hydride battery

2.4 SUPERCAPACITOR.

Because of its great power density and long lifetime, electrochemical super capacitors (ES) or ultra capacitors are in high demand. In 1957, the first super capacitor was developed. Super capacitors begin to gain attention in the field of HEVs after the 1990s. In a hybrid electric car, the primary function of a super capacitor is to boost the battery/fuel cell to provide the necessary power for acceleration. The US Department of Energy has determined that ES will be as significant as batteries in the future of energy storage applications. There are two types of electrochemical super capacitors: faradaic super capacitors (FS) and electrostatic.

2.5 CHARGING SCHEMES

A charger to charge a battery is a necessary component of a BEV. Charging is more than just charging a battery; it needs a sophisticated control system to regulate current and voltage. The charger can be integrated into the vehicle or used as a stand-alone charger at a charging station. The charging and discharging processes are important in determining a battery's safety, durability, and performance. There are several charging techniques for electric vehicles, including constant current, constant voltage, and a mix of constant voltage and constant current. Because of regenerative braking, random battery charging is needed for EVs. So, there are different levels of charging an EVs-

- I. Slow charging
- II. Semi-fast charging
- III. Fast charging

Table -1: comparison of level of charging of EV

Quantity	Level 1	Level 2	Level 3
Voltage (V)	120	208/240	200-450
Current (A)	15	40	125
Useful power (kW)	1.4	7.2	50
Maximum output (kW)	1.9	19.2	150
Charging time (h)	12	3	0.33

3. TYPES OF ELECTRIC VEHICLES

The most recent mode of transportation, EV, is also defined as a motor vehicle powered by an electric propulsion system. Hybrid electric vehicles (HEVs), battery electric vehicles (BEVs), and plug-in hybrid electric vehicles (PHEVs) are all examples of electric cars (PHEV). The utilisation of batteries in electric vehicles provides a distinct advantage over conventional automobiles. EVs are silent in operation, aid in the elimination of flue gas emissions produced by conventional vehicles, and the most important element is the EV's three-fold cheaper operating cost. Unfortunately, batteries have several drawbacks as well, such as significant weight, expensive battery costs, and volume restrictions.

3.1 BATTERY ELECTRIC VEHICLE (BEV)

BEVs are powered by a battery and an electric motor, and they run entirely on electricity stored in a large battery. BEVs can be charged from the grid as well. One of the most important aspects in the transportation sector, particularly in the realm of electric vehicles, is batteries. So, when it comes to batteries, the most important considerations are cost, climate, energy density, and power density. Electric vehicles have two major drawbacks: a short range and a short cycle life. As a result, to resolve these challenges in an antique manner. Because of its strong architecture and high charge rate acceptance, the author chose lead-acid batteries.

The author described the pulsed type algorithm for optimum lead oxide morphology in relation to the battery's cycle life. As a result, the vehicle's range is determined by the battery configuration, power density, and energy density. Because LIB technology is most suited for vehicular applications in EVs, the industry uses LTO and LFP cell technologies. Depending on the battery capacity, BEVs have a range of 100-400 km. The amount of time it takes to charge a battery depends on its configuration and capacity. The ambient temperature has an impact on it as well. Furthermore, we are working to extend the range of electric vehicles.

3.2 HYBRID ELECTRIC VEHICLE (HEV)

Hybrid refers to a vehicle that is propelled by a mixture of two or more sources, each of which can drive the vehicle independently. Fuel cell, gas turbine, pneumatic, ethanol, electric motor, solar, hydraulic, and many other hybridization systems have been created in recent years. Electric motor and internal combustion (IC) engine are the most proven and established of these techniques. A bi-directional energy storage system is one type of HEV, while gasoline with an engine as a fuel converter is another. Regenerative braking, which turns kinetic energy into electrical energy to charge a battery, is being used in HEVs as an efficiency-improving technology. According to past reviews, the traditional IC engine emits a lot of hazardous fumes, wastes a lot of gasoline in heavy traffic, and so on. By switching to power transmission through the motor and shutting off the engine, HEV overcomes all of the problems of IC engines. Another benefit of HEVs is that if the fuel tank runs out while travelling, the vehicle may be operated on electric power for the remainder of its range. According to its construction, the HEV is divided into three categories.

Table -2: comparison of various EV from the market

Vehicle model	Range (km)	Charge time (h)
Tesla Model S	335-426	5
BMW i3	160	6
Mitsubishi IMiEV	100	7
Ford Focus EV	110	4
Smart EV	109	6

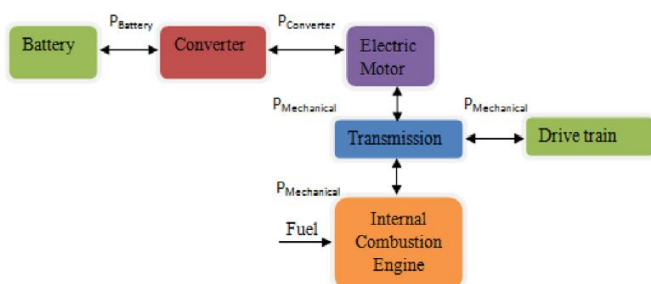

Fig -3: Power Flow of Hybrid EV

4. TESTING FOR EVS

Various tests are carried out on the batteries in order to establish the operational parameters of the battery so that it can function consistently and resist failure. The ETA-TP004 and SAE J227 test benches are used to conduct range testing at a constant speed. For range testing, there are a few requirements that must be met.

- I. Battery pack temperature should be within the range of
- II. 60 _F and 120 _F.
- III. Wind speed at the test location recorded during a test
- IV. should not exceed ten mph.
- V. EV accessories should not be used during the test activities.
- VI. Range related tests should always commence with batteries, initially charged to the standard point
- VII. By using rapid charging.
- VIII.
- IX.

The range test lasts up to three days and includes various driving periods. It aids in determining the maximum driving range gained over a 12-hour period. The average mileage for each day are calculated by averaging the total miles driven by the EV over a three-day period. The driving test, which is performed on the EV for safety reasons, is the second sort of test.

The following parameters are checked during the driving test –

- I. Average speed of the vehicle.
- II. Average distance required for charge.
- III. Average distance traveled between charges.
- IV. Average kWh available per charge

The final type of test that batteries must pass is a safety test. These tests assess the battery's properties as well as how the battery will react in unusual or extreme settings. Mechanical testing, electrical tests, and environmental testing are the three stages of the safety tests.

5. TRANSMISSION SYSTEM

The transmission system could be simplified at the early design stage by using three mechanical components from simulink libraries that are installed on the global model and coupled to the motor output. The gearbox, the wheel, and the vehicle's mass are among these components. There are different values for the parameters connected to the components for each vehicle model. As a result, before starting the simulation, the designer should provide all of the transmission system's features. The gear ratio R_g , the wheel radius r_w , and the vehicle mass M_v are the three primary characteristics necessary to build the transmission system in this situation.

5.1 RESISTIVE FORCES

This section consists of two blocks. The first block is made up of a mathematical equation that calculates the resistive force based on the vehicle's current speed, and the second block takes the obtained result and converts it into a response force that is applied to the transmission system's final section.

5.2 BRAKING AND STEERING

In the past, a vehicle's braking system was based on a mechanical mechanism such as a disc brake. Both mechanical and electrical brakes should be integrated into an EV's braking system. Electrical power regeneration braking should be used in the first region of the braking pedal. The kinetic energy of the vehicle can be returned to the battery when decelerating or driving down a slope. Mechanical braking is utilised in the last part of the braking process. This achieves a balance between energy efficiency and safety. We can now create motors with high regeneration power at the expense of motor size, but a balance between motor weight, cost, power regeneration efficiency, and safety is required. To expand the power regeneration range, the motor should be designed to accept the high power design plugging mode, which provides high reverse torque to stop the vehicle. The motor drive should also include a high frequency decoupling capacitor to absorb the reverse current's quick transient.

6. SIMULATIONS AND OUTPUT WAVEFORMS

This section details the modelling and simulation and analysis of the electric vehicle. MATLAB/SIMULINK is used as tool to develop electric vehicle model.

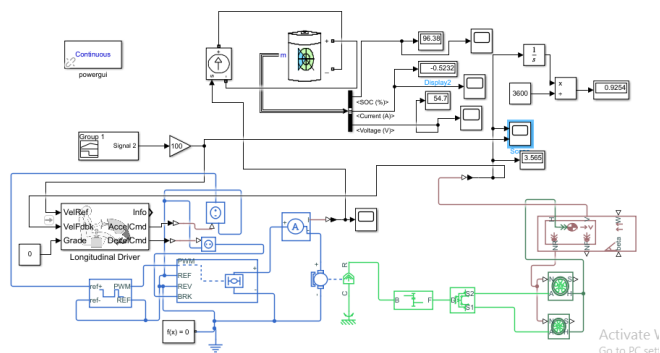

Fig -4: Simulation circuit model of EV

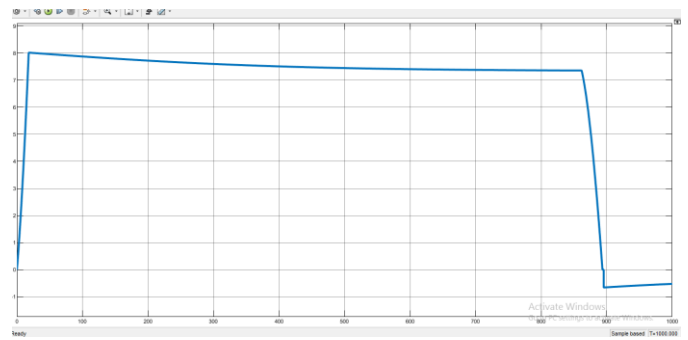

Fig -5: Current flow in the DC motor

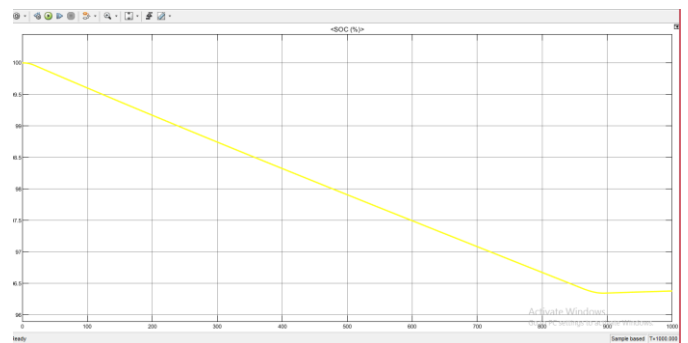

Fig -6: Battery SOC

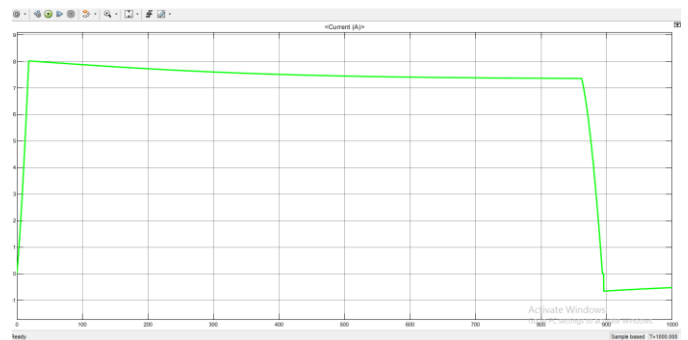

Fig -7: Current through the battery

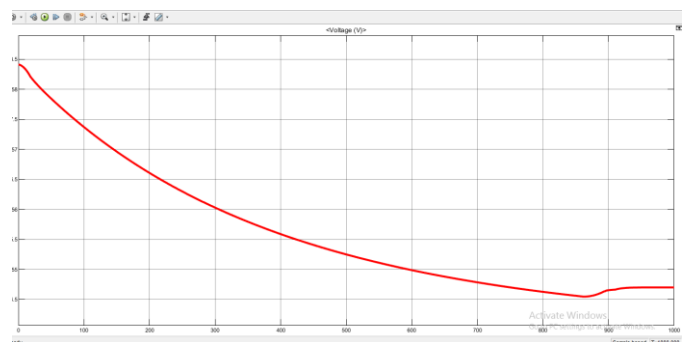

Fig -8: Voltage at battery terminal

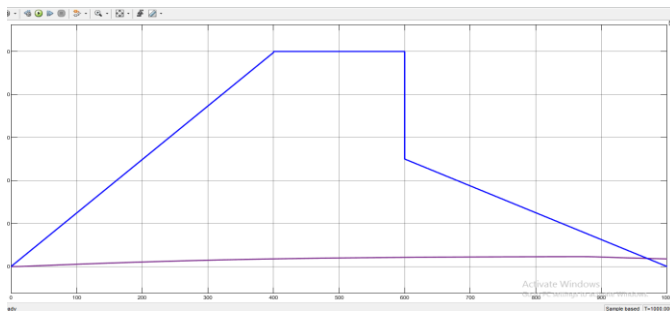

Fig -9: Reference speed and accelerated speed at motor terminal

7. CONCLUSIONS

The current state of electric vehicles is discussed in this study. The study begins with a description of the general structure before moving on to energy storage. After then, it moves on to subsequent car components. The article gives an overview of recent electric vehicle (EV) efforts in the region. Hybrid, Plug-in Hybrid, and Electric Automobiles can improve vehicle fuel economy while also increasing the cost of ownership when compared to standard vehicles. In general, their lower petroleum consumption and improved productivity provide long-term economic benefits to purchasers, society, automakers, and governments. This document presents a comprehensive review of the literature, as well as an overview and guidelines for HEV, PHEV, and BEV penetration rate studies in India. The Indian government's latest measures and numerous incentives will aid in the country's e-mobility push. When non-conventional energy sources are unavailable, the creation of a new Vehicle-to-Grid idea can either send power to the grid or be utilised to charge the battery. This technology is crucial for energy security, renewable energy, and addressing global warming concerns. This study summarises the challenges and issues with electric vehicles in India, and it is the first of its kind.

REFERENCES

- [1] N. Daina , A. Sivakumar , J.W. Polak , "Modelling electric vehicles use: a survey on the methods, *Renew. Sustain. Energy*" Rev. 68 (2017) 447-460 .
- [2] F. Koyanagi , Y. Uriu , "Modeling power consumption by electric vehicles and its impact on power demand, *Electr. Eng*". *Jpn. 120* (4) (1997) 40-47
- [3] C. Weiller , "Plug-in hybrid electric vehicle impacts on hourly electricity demand in the United States, *Energy Policy*" 39 (6) (2011) 3766-3778 .
- [4] M.D. Galus , M.G. Vayá , T. Krause , G. Andersson , "The role of electric vehicles in smart grids, *Wiley Interdiscip*". *Rev.: Energy Environ. 2* (4) (2013) 384-400
- [5] F. Salah , J.P. Ilg , C.M. Flath , H. Basse , C. Van Dinther , "Impact of electric vehicles on distribution substations: a Swiss case study", *Appl. Energy* 137 (2015) 88-96 .
- [6] L. Lu , X. Han , J. Li , J. Hua , M. Ouyang , "A review on the key issues for lithium-ion battery management in

electric vehicles", *J. Power Sources* 226 (2013) 272-288 ics, 56(6), 2086-2094 .

- [7] D.B. Richardson, "Electric vehicles and the electric grid: a review of modeling approaches, Impacts, and renewable energy integration", *Renew. Sustain. Energy Rev.* 19 (2013) 247-254 .
- [8] S. Bashash , S.J. Moura , J.C. Forman , H.K. Fathy , "Plug-in hybrid electric vehicle charge pattern optimization for energy cost and battery longevity", *J. Power Sources* 196 (1) (2011) 541-549 .
- [9] S.B. Peterson , J.F. Whitacre , J. Apt , "The economics of using plug-in hybrid electric vehicle battery packs for grid storage", *J. Power Sources* 195 (8) (2010) 2377-2384 .
- [10] A.M. Andwari , A. Pesiridis , S. Rajoo , R. Martinez-Botas , V. Esfahanian , "A review of battery electric vehicle technology and readiness levels", *Renew. Sustain. Energy Rev.* 78 (2017) 414-430 .

BIOGRAPHIES



Mr Abhimanyu Mandal (1st author) is a Assistant professor of Electrical Engineering, at Christian College of Engineering and Technology ,Bhilai, Chhattisgarh, India. His broad area of research interest is Renewable Energy sources.



Mr Akash Dewangan (2nd author) is a Assistant professor of Electrical Engineering, at Christian College of Engineering and Technology ,Bhilai Chhattisgarh, India. His broad area of research interest is Power System.



Mr Shashank Tiwari (3rd author) is a Assistant professor of Electrical Engineering, at Bhilai Institute of Technology, Durg Chhattisgarh, India. His broad area of research interest is Power Electronics & Drives .