

# Study on Rheological behavior of SCC using Concrete Shear Box

MUGHASHE S SEMA<sup>1</sup>, NAGENDRA NAIK<sup>2</sup>, RAKESH H P<sup>3</sup>, MANJUNATHA K<sup>4</sup>

<sup>1-4</sup>UG Students, Dept. of Civil Engineering, DSCE College, Bengaluru, Karnataka, India

\*\*\*

**Abstract** - Rheology may be defined as the determination and flow of materials under external forces. Workability of concrete mix is closely related to the flow properties of concrete and there is a need to develop and understand methods based on the material science approach. Fluid Rheology is already well established and widely used science that can be applied to the property of fresh concrete. The fresh properties of concrete can be organized by its flow behavior. Most of the laboratory tests which measures the motion of concrete are empirical in nature. The rheology may be defined as the scientific description of flow properties. Usually the rheological properties of SCC are characterized by the Bingham's parameters namely yield stress and plastic viscosity. Rheological test conducted using apparatus such as **BML** Rheometer, **BTRHEOM** Rheometer, **IBB** Rheometer and **TWO POINT** Rheometer attempt to find the yield stress and plastic viscosity. But there is no similarity among the test values and thus there is no apparatus that is acceptable to all. Further these rheometers are very expensive and may require extensive knowledge on how to operate. To overcome this; concrete shear box formulated by Dr. S. Girish to determine the fresh properties of SCC is used and applied to the tests.

In this particular study a thorough attempt has been made to apply a concrete shear box test to measure the yield stress and plastic viscosity of normal concrete shear box test to obtain yield stress and plastic viscosity of normal concrete. In this particular work, three displacement rates such as 1mm/min, 5mm/min, 15mm/min and normal stresses of 1kg/cm<sup>2</sup>, 2kg/cm<sup>2</sup> and 3kg/cm<sup>2</sup> used for SCC. The water content used was 175 lit/m<sup>3</sup> and cement content of 300 to 450 kg/m<sup>3</sup>. The results show that concrete shear box test can be applied to find the rheological parameters of fresh concrete as a static test. The values obtained in this experimental work are higher as compared to the values obtained by other rheometers. This is due to inter-particle interference. But, the trends are very similar to the studies done applying rheometers.

## 1.INTRODUCTION

Concrete is the most widely used construction material in the world. The reason for widespread use of concrete being its adaptability, strength, durability, availability, and economy. Concrete always goes through different stages as it develops strength and gets cured. After mixing and while still workable and easily manipulatable, it is said to be fresh. When it begins to become solid, but still weak, it is described as being green. Finally, the concrete is said to be at a hardened state. It has two unique properties-

1) Fresh properties

2) Hardened properties

Fresh properties of concrete also especially known as workability. The Indian code of practice defines workability as that "property of freshly mixed concrete, which determines the ease and homogeneity with which it can be mixed, transported, placed, compacted and finished". The American standard of testing materials (ASTM:125-93) defines workability as that "property of determining the effort required to manipulate a freshly mixed quantity of concrete with minimum loss of homogeneity".

Workability of fresh concrete is an important parameter which can affect many other properties and can change strength, durability and also appearance and cost. Workability has always been the main characteristic of fresh concrete.

Fresh concrete has direct effect on the quality and cost of construction using concrete. They also drastically determine the certain hardened concrete properties, such as uniformity, strength and durability.

For more than 81 years, the workability of fresh concrete has been calculated predominantly throughout the world with one simple and the longest used traditional test for concrete -the slump test. In this so called slump test, a sample of fresh concrete is placed in a 12-inch tall hollow conical mould made usually of mild steel. The mould is removed after the concrete has ben rested for about a minute and the vertical distance the concrete degrades, or slumps, is recorded as a measure of workability parameter. Whereas workability is a broadly used term, the slump test measures only one aspect of workability, namely-consistency.

Although the introduction of the so called slump test as an ASTM standard test in 1922 signified an important advance in the design and control of concrete mixes, the slump test is now presumed to be incapable of providing an accurate characterization of the workability of today's much more advanced concrete mixes.

The behavior of fresh concrete is further complicated by the addition of different types of materials as well as marginal materials. Most of the tests developed since the beginning of the 20<sup>th</sup> century are empirical, i.e, they attempt to simulate a field placement parameter and record a single value such as time or distance, which serves as the index of workability. The methods applied to calculate the workability of concrete has not yet changed significantly over the past century and is still being calculated using the empirical test, in particular,

the old slump test. But the slump test has many deficiencies in properly identifying a mix and it is further being compounded with concrete of today is transforming itself from basic four ingredient mixture to multiple ingredient mixture with the addition of mineral and chemical admixtures.

The measurement of workability by using the traditional tests in particular slump test has more disadvantages which will be described later in the paper. For which further study of the concrete with respect to material science approach. It was in 1983 that Tattersall and Banfill, observed and pointed out that workability can be misleading and that it can be interpreted in a number of ways. They argued that the empirical tests are single point tests and suggested quantitative fundamental science approach for categorizing fresh concrete with at least two parameters if not more to describe the behavior and pattern in fresh state.

Workability of concrete is measured by rheological properties to overcome the disadvantages of the empirical tests, in particular, the slump test and it is based on material science approach.

Rheology deals with flow of materials under loads and other external influences, it is a well established science. The concept of rheology can be extended to concrete since workability is related to flow properties and concrete can be considered as a fluid with solid particles in suspension (i.e. aggregates in a viscous liquid). Rheology is derived from the Greek word "Rheo" meaning - "everything is in flow". The main objective of rheology is to predict the internal motion behavior of complex materials under applied forces and the geometric effects in a fluid. It is being used in different fields such as concrete, ceramics, paint industries, polymer, food technology, pharmacy etc. Many fluids have some minimum stress like a yield stress-that must be exceeded before flow takes place. Flocculated system such as cement paste are usually thixotropic and show yield stress. The concept of yield stress is usually seen in concrete slump although it is an empirical test. Even though fresh concrete can be categorized as a fluid, the characterization of its rheology is complicated as concrete is a complex heterogeneous material with time-dependent properties. However, workability of fresh concrete mix is closely related to the flow properties of concrete and there is a need to develop the methods and alternatives based on material science approach especially with the invention of special concrete. Finding the rheological properties of fresh concrete will always be the focus of the concrete industry.

Various models or equations have been developed and propagated to characterize the flow of concrete. Freshly mixed concrete can be considered as a concentrated suspension of aggregates in cement paste and be measured as a viscous or visco-elastic fluid that is based on the relationship between its shear stress( $\tau$ ) and shear rate( $\dot{\gamma}$ ); expressed as a flow curve. Most researchers and

studies agree that the flow of concrete can be described accurately upto an extent by using Bingham's equation. The equation is a linear function of the shear stress versus shear rate. Two parameters given by Bingham's equation are the yield stress and plastic viscosity. Compared to a Newtonian model; the Bingham model incorporates yield stress ( $\tau_0$ ) and viscosity is mostly replaced with plastic viscosity ( $\mu$ ). It describes a linear relationship between stress acting to shear concrete and the rate at which it is sheared with plastic viscosity being the slope in this relationship and the y intercept marks the yield stress( $\tau_0$ ) and the relation is as follows:

$$\tau = \tau_0 + \mu \dot{\gamma}$$

The term yield stress and plastic viscosity provides a more accurate description of fresh concrete than it's conventional workability tools. The concrete pump ability is determined by plastic viscosity and stability of fresh concrete placed at an angle is determined by the yield stress. For advancements to be made in understanding and controlling workability of fresh concrete, test procedures, methods and standards must move to a more fundamental qualitative basis. Therefore, workability should be defined or expressed in terms of established measurable parameters such as yield stress and plastic viscosity. Today, by the use of Rheometers, concrete Rheology has emerged as a viable and trusted technique for characterizing workability of concrete mixtures.

## OBJECTIVES

The main objective of the study is

- To evaluate and calculate the rheological properties such as yield strength and relative plastic viscosity of SCC concrete by shear box.
- To calculate the rheological reproducibility of aggregate, various water to cement ratio & different size of aggregates.

## II. LITERATURE REVIEW

Today's modified concrete is mainly composed of four ingredients mix (cement, water, fine aggregates, and coarse aggregates). The modifications are done with the addition of new ingredients like filler material, mineral and chemical admixtures are also added to improve the quality of concrete mixture. It has two states; fresh and hardened state. The workability of fresh concrete is an important property which has direct impact on the strength, durability, appearance and cost. Workability is also defined as the property of freshly mixed concrete that determines the ease and homogeneity with which it can be mixed, placed, transported, consolidated and finished.

But the apparatus to assess the workability of concrete has not changed significantly in the last century and is measured using the simplistic test method, the slump test, the

apparatus which was developed in the USA around 1910 and it is believed that it was first used by Champman although in many countries the test apparatus is associated with Abram. Later on, other workability tests like the re-mould test, flow table test, compacting factor test, Vee-Bee test, ball penetration test etc were developed since the 1920's are empirical, that is, they attempt to simulate a field placement condition and measure the values such as time or distance, which serves as an index of workability.

In 1986, Tattersall interpreted and divided the workability test in to three classes namely, Qualitative, Quantitative Empirical and Quantitative fundamental science and argued that the empirical tests are single point tests and suggested quantitative fundamental science approach for characterizing the fresh concrete.

**\*DRAWBACKS OF SLUMP TESTS**

a) **ZERO SLUMP**- basically is the slump test quite incapable of differentiating two concrete of very low workability (Zero slump). The reason two concrete with the same slump may behave differently during placement is that concrete flow cannot be defined by a single parameter.

Concrete with the same slump can exhibit different behavior when tamped with a taming rod. A harsh concrete with less powder or paste will tend to fall apart when tapped and a cohesive concrete with adequate or more powder or paste percent may not fall off apart when tapped and thus suitable for difficult placement condition than the mix with the same slump value.

b) **STATIC TEST**- the slump test is static, not dynamic test; therefore, the results are influenced by concrete thixotropy. The test does not provide an indication of the ease with which concrete can be moved under dynamic loading conditions such as vibrations.

c) **NOT A SCIENTIFIC APPROACH**- slump test is not based on basic material science approach and not a test to be relied for fundamental approach . The test results are subjective assessment which can have disagreements among the persons involved about the exact meaning of workability.

**\*RHEOLOGY**

Rheology is the science of deformation and flow of matter. The term Rheology was invented in 1920 by Prof.Eugen.C.Bingham at Lafayette College in Indiana. The "Rheo" is from the Greek words "pantarhi", meaning 'everything is in flow', so the Rheology was taken to mean the theory of deformation and flow of matter. It is well established combination of physics and chemistry branch and applied in different fields like asphalt, ceramics, paint industries, polymer, food technology, pharmacy, lubricants and others. The main objective of Rheology is predicting the fluid flow that would be produced due to applied forces.

Basically fluids are classified as

- (a) Newtonian and
- (b) Non-Newtonian fluids

**(a) Newtonian fluids**

\*The Newtonian fluids follow the simple rheological equation known as Newton's law of viscosity (Eq.).

\*Generally the rheological behavior shows the linear relationship and passes through the origin.

\*Water and mineral oils are common Newtonian liquids.

$$\tau = \mu \dot{\gamma}$$

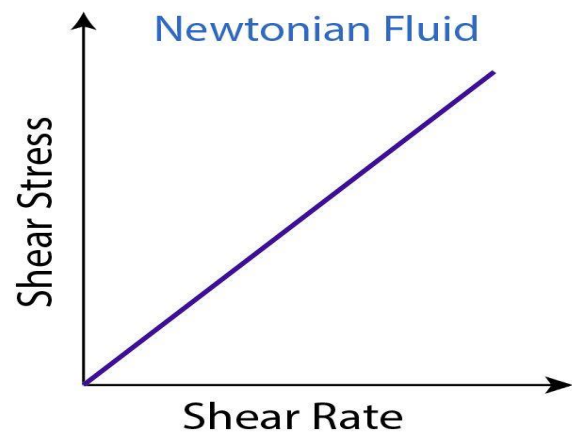

**(b) Non-Newtonian fluids**

\*non-Newtonian fluids do not obey Newton's law of viscosity (Eq.).

\*the shear stress is non-linear functions of the shear strain rate.

\*non-Newtonian fluids are further divided as time dependent and time independent fluids.

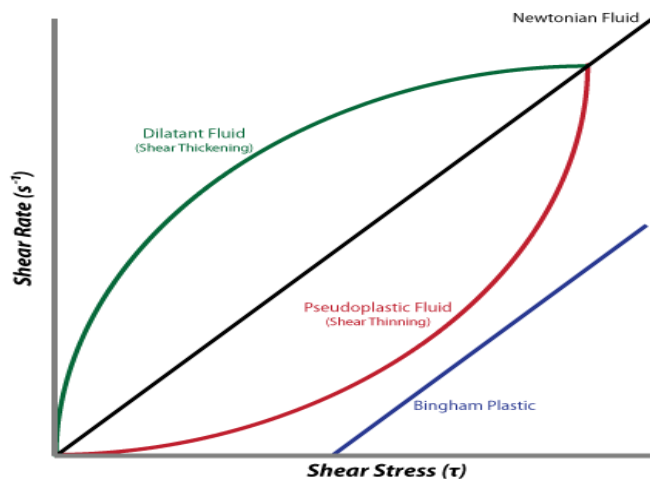

Workability of fresh concrete mixture is closely related to the flow properties of the concrete and the fresh concrete is assumed as a fluid consisting of two phase system; cement paste and aggregate phase and aggregate in turn suspended in cement paste. Fresh concrete can be considered as a concentrated suspension of solid particles in viscous fluid that is, the cement paste, and the cement paste itself is concentrated suspension of cement grains in water, hence concrete is considered as multi-phased fluid.

Yield stress commonly occurs in multi-phase fluids such as concentrated suspensions. The solid particles interact to form a flocculated three dimensional network structure that resists the flow at a sufficiently low stress. Flocculated systems such as cement pastes typically are thixotropic and exhibit a yield stress. The yield stress is related to the force required to break down this structure and initiate flow. The concept of yield stress is readily seen in concrete slump test.

The fresh concrete can be considered as Bingham fluid and is based on the relationship between shear stress ( $\tau$ ) and shear strain rate ( $\dot{\gamma}$ ) expressed as a flow curve. Generally yield stress is related to concrete slump and plastic viscosity is related to the time of concrete slumping

### III. METHODOLOGY

The experimental methodology consists of obtaining mixes with different cement contents of ranges from 300 to 450 kg/m<sup>3</sup> and water contents of 175 lit/m<sup>3</sup> were used. The displacement rate ranges from 1mm/min to 15 mm/min. The shear stress developed at such a faster rate is captured using servo-controlled data acquisition system. The loading unit has different normal stresses up to maximum of 3kg/cm<sup>2</sup>. The size of the sample was 150 mm cube and can be tested for coarse aggregate of maximum size 25mm. The normal loads are applied on the specimen through a pneumatic actuator and a stress regulator. Electronic data acquisition system is used in acquiring the data and storing it to computer. The important characteristics of this test are the static condition of the test and very low shear rate

applied on the specimen during testing which is similar to conditions experienced by the concrete in the field.

### 1) PROCUREMENT OF MATERIALS

Materials used:

**\*CEMENT:** all types of cement complying with the Indian standards are suitable for making concrete. The choice of the type of cement and content depends on the strength requirement, the exposure class for the durability and the minimum amount of fines required for the mix.

**\*FINE AGGREGATE:** Sand plays a very important role in concrete. It manages to fill the voids between the powders and coarse aggregates. That is why sand must be well graded from a particle size point of view, in order to guarantee the filling between the various aggregates as much as possible, sand can be finer than normal, as the material less than 150 micron may help to increase cohesion, thereby resisting segregation.

**\*COARSE AGGREGATE:** concrete can be made from most normal concreting aggregate. Coarse aggregate differ in nature and shape depending on their extraction and production. SCC has been produced successfully with coarse aggregate up to 40mm. The maximum size depends on the reinforcement layout and formwork dimensions in the same way as traditional vibrated concrete. Natural aggregate requires less water than crushed aggregates in SCC. However, elongated aggregate are not suitable.

**\*WATER:** Potable water as obtained from the bore well will be used for the preparation of the concrete mix and for curing as per Indian standards.

### 2) TESTS ON MATERIALS

Test on materials used:

- \*Test on cement
- \*Test on fine aggregates
- \*Test on coarse aggregates

#### a) TEST ON CEMENT:

##### Standard consistency test:

The consistency at which cement paste will permit penetration of Vicat plunger having 10mm dia. and 50 mm length to a depth of 33-35 mm from the top of the mould is defined as the Standard Consistency of cement.

A standard consistency test of the cement is to find out the water content required to produce a cement paste of standard consistency. Consistency is referred to as the ability by a flow of a freshly mixed concrete paste or mortar. The



consistency of cement is also called as a standard consistency or normal consistency.

**Apparatus of Standard Consistency test of cement**

**Vicat Apparatus:**

The Vicat apparatus shall consist of: \*a frame is having a movable rod with a platform at one end and the following needle which can be attached at the other end.

- \*NEEDLE: (a) Needle for determining the final setting time.
- (b) Needle for determining the initial setting time.
- (c) Plunger for determining the standard consistency.

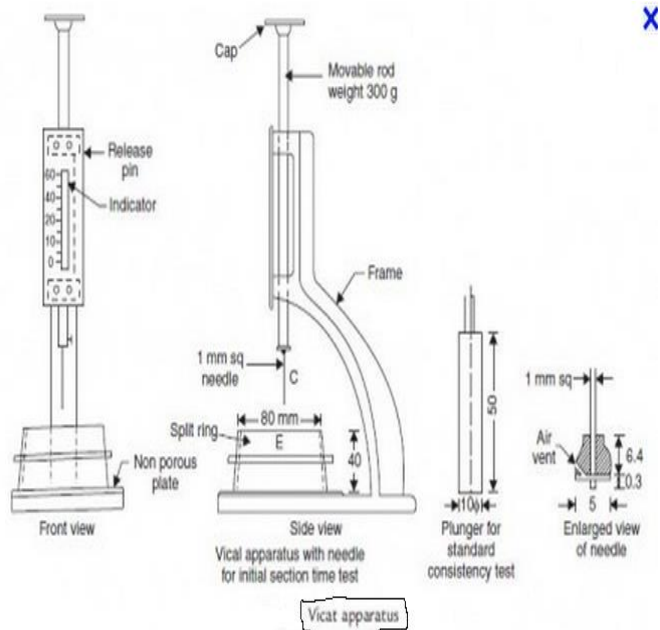

\*GRADUATED SCALE: graduated scale shall be of 40mm length and the smallest division on the scale is 1mm.

\*VICAT MOULD: internal diameter of 70±5 mm at the top, 80±5mm at the bottom and a height of ±0.2 mm.

\*GAUGING TROWEL: gauging trowel conforming to IS 10086:1982. The test result should be 33-35mm measurement from the top of the scale in Vicat apparatus. At this penetration, the percentage of water is denoted as a consistency.

**OBSERVATION:**

Weight of cement 300 grams

**RESULTS:** Normal consistency of cement is (P) 28%

**TECHNICAL REFERENCE:** IS 4031(Part-4) 1988

**b) TEST ON FINE AGGREGATES:**

**Sieve analysis:**

Sieve analysis of aggregate is done to determine its particle size distribution, fineness modulus, effective size and uniformly coefficient.

**Observation.**

\*Weight of fine aggregate 1000 grams.

Fineness modulus =  $\Sigma F / 100$

**RESULTS:** The fineness modulus of the fine aggregate is 3.7 (ZONE 1).

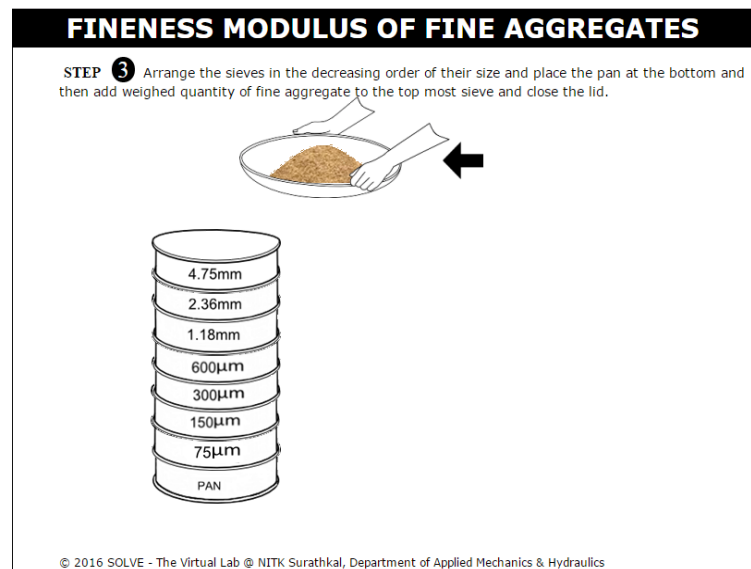

**c) TEST ON COARSE AGGREGATES:**

**Specific gravity and water absorption test:**

Empty weight of the basket in water (x) = \_\_gm

Aggregates with basket after soaked for a period of 24 hours (y) = \_\_gm

Weight of aggregates saturated (A) = y-x= \_\_gm

Weight of the oven dried aggregates (C) = \_\_gm

Specific gravity of coarse aggregates = C / (B-A)

Apparent specific aggregates = C / (C-A)

**RESULTS :** The Specific gravity of coarse aggregate is 2.57 .



### Water absorption:

Water absorption (percentage by dry weight) = 0.47%

## 3) EXPERIMENTAL PROGRAMME

### a) Preparing the setup

Before mixing the concrete, Direct Shear Box and the other units should be kept ready as follows

- \*Turn on the computer and execute the tango software.
- \*Turn on the data Acquiring Electronic Unit and set it to Zero, and enter the time and date if necessary.
- \*Place the lower half of the shear box with the base plate and gripper plate inside the housing.
- \*Place the upper half and insert the shear keys.
- \*Adjust the housing so that it is in touch with gear box lead screw.

### b) Preparing the specimen

- \*About 8.5 kg of concrete is required to perform one trail of Direct Shear Box test, once the setup is ready as explained above, mix the concrete. Pour about 8.5 kg of concrete in the shear box, so that level of concrete is below 30mm from the top of the shear box.
- \*Place the gripper plate and loading pad with the steel ball and then place loading yoke above this. Now apply the desired normal stress by adjusting the pressure gauge and enter the desired strain rate in control panel and remove the keys.

### c) Performing the test

- \*Start the data acquiring electronic unit first so that every single value is recorded.
- \*Use the control panel to shear the specimen.

\*Observe the values in display unit (Computer).

\*Once load is dropped, stop the data acquiring electronic unit and then stop the shearing unit.

\*Terminate the data acquisition and store the data giving the unique file name by using Tango software.

\*Stored data can be analysed using direct shear box software (Tango software).

## Results

Mix Designation	Cement (Kg/cm <sup>3</sup> )	Water (liter/m <sup>3</sup> )	Volume of paste	Yield stress (Pa)	Plastic Viscosity Y (pa-s)
M1	300	175	.37	6400	9.9
M2	300	175	.39	6000	8.1
M3	375	175	0.39	8300	37
M4	375	175	0.41	3100	5.4
M5	450	175	0.37	6700	9.0
M6	450	175	0.39	-756	-6.1
M7	450	175	0.41	-1152	-2.7

## IV. CONCLUSIONS

Rheological Properties of fresh concrete, namely plastic viscosity and yield stress are critical for the concrete industry because they affect placement and workability. The rheological behavior of self compacting concrete is mostly characterized by empirical test methods like the slump flow test, therefore proper characterization of these properties is needed to control the quality of fresh concrete and ensure sustainability of concrete structures.

From the experiments conducted in the present study, though limited in nature, the conclusion can be arrived as follows.

- \*It is possible to determine the relative yield stress and relative plastic viscosity which are similar to Bingham parameters using direct shear box.
- \*The rheological parameters are named as relative yield stress and relative plastic viscosity because the values obtained in this study are higher than that reported in the literature using rheometers.
- \*As the cement content increases higher yield stress and higher plastic viscosity can be achieved when the water content is kept constant.
- \*Concrete shear box can be alternative in place of expensive rheometers for obtaining Bingham parameters.

**REFERENCES**

1. Ajay.N and S. Girish, "Importance of rheological properties of fresh concrete"- A review, The Indian Concrete Journal, Vol. 91, Issue 9 , September, pp. 09-17, 2017.
2. B.S. Santosh and S. Girish , "A new methodology to study the rheological properties of fresh Portland cement concrete", International Journal of Earth Sciences and Engineering, Vol.04, No. 06, SPL, Pp. 797-800, 2011.
3. B.S. Santosh, L. Shobha, G.S.V. Kumar, "Rheological measurement of Fresh Portland Cement Concrete using Direct Shear Box tests, International Conference on "Concrete in the Low Carbon Era", University of Dundee, Scotland, UK, 2012.
4. C.F. Ferraris, Measurement of Rheological Properties of High Performance Concrete: State-of-the-Art Report, National Institute of Standards and Technology, NISTIR 5869, Vol.104, September-October, pp.461-478, 1999.
5. C.F. Ferraris and F.de. Larrard, Testing and Modeling of Fresh Concrete Rheology, NISTIR-6094, February, 1998.
6. David W. Fowler and P. Koechler, Development of a portable rheometer for fresh Portland cement, The University of Texas, Austin.
7. Girish Kumar S and Hrushikesh, "A scientific approach to measure the workability of concrete using concrete shear box".
8. G.H Tattersall and P.F.G. Banfill, "The rheology of fresh concrete", First edition, Pitman, Boston, London, Melbourne, 1983.
9. H.A. Barnes, The 'Yield Stress Myth?' Paper-21 Years On, Applied Rheology, Vol.17, Issues 4, pp.43110-1-42110-5, 2007.
10. K. Walters and H.A. Barnes, "The yield stress myth/" Rheologica Acta, Vol.24, No.4, pp.323-326, 1985.