

Experimental Detection of the Hydraulic Cylinder Internal Leakage

Sabry Allam¹, Mosaad Atia²

¹Professor of Automotive Engineering, Dept. of Automotive technology, Faculty of Technology and Education, Helwan University, 11281 Cairo, Egypt.

²M.Sc. Student at Dept. of Automotive Technology, Faculty of Technology and Education, Helwan University, 11281 Cairo, Egypt.

Abstract - Hydraulic systems are used in many industrial applications such as control aircraft, ships and heavy equipment because they have many engineering advantages such as high power that can be generated from a small area and high precision control.

After a period of use, the hydraulic cylinder inner seal (moving seal) will wear out, resulting in oil leakage from the high pressure chamber to the low pressure chamber (internal leakage). This leads to poor cylinder performance. This fault is difficult to detect in the early stages, and requires high-precision hardware to detect it. This paper proposes a method for detecting and estimate internal leakage using low-cost instruments. Based on measuring return oil with measuring devices attached to the system, the proposed methodology in this research proved its high accuracy in detecting internal leakage and estimating the amount of leakage, and the possibility of working with any type of directional control valves used with hydraulic cylinders. No gauges are required on the outside of the cylinder which is difficult in practical applications due to the confined spaces for placing the cylinder such as in heavy equipment

Key Words: Hydraulic, Cylinder, Internal Leakage, Experimental, Detection

1. INTRODUCTION

Hydraulic systems are used in many industrial applications including aircraft and heavy equipment due to the ability to produce high forces, torques and high accuracy Jilali. et al [1]. Precision is critical to proper operation in these applications. Thus, monitoring of hydraulic systems is of great importance in industrial fields. Therefore, it is important to study fault diagnosis (FD) schemes that can detect abnormal conditions in the hydraulic system Isermann et al [2]. FD systems can also be used with fault-tolerant control system modules that are designed to react to changes in fault-causing system parameters, through fault adaptation or reconfiguration Karpenko et al. [3]. Hydraulic fluid leaks can be classified into: (1) the internal leak (cross port), where the fluid leaks from the high pressure paths to the low pressure paths inside the hydraulic system, and the external leak, where the fluid leaks out of the hydraulic system. While the external leakage can be easily detected, inspected visually. the internal leakage is difficult to detect, When the piston seal is completely damaged the actuator fails to respond to

control signals. Thus, it is important to consider attending to this fault as part of any system state monitoring strategy. Fault detection methods applied to hydraulic systems are described by [4]. The aim of this research is to diagnose internal leakage. Watton et al.[5] worked on neural networks based on dynamic feature extraction technique to identify the type and level of leakage in hydraulic systems. Similarly, Tan et al.[6]. introduce the concept of Volterra's nonlinear modeling to aid the implementation of the FD scheme in hydraulic systems. By monitoring changes in hydraulic supply pressure, he succeeded in detecting internal leaks in the actuators. Sepehri et al. [7]. studied the use of EKF to implement an FD scheme for internal and external leakage faults detection. They developed this study to include both friction and external loading for actuators that follow random inputs. use Shi et al. [8]. A linear model with an adaptive threshold in order to overcome the difficulties associated with modeling non-linear hydraulic systems, to detect internal and external leaks. In generally, fault detection methods can be divided into, Model based and non-Model based. Diagnosis methods techniques for fluid power systems have been well documented [4].

1.1. Model based

Model based fault detection method Using a mathematical model that describes the fault of the system and compared actual measured value by sensors with an estimated value of a mathematical model. The difference between them is fault indication but mathematical model may complicate the problem. Moreover, obtaining a mathematical model an accurate describing the fault is very difficult due to the friction and corrosion of some parts of the mechanical system [4]. Although the model approach is reliability and effectiveness, it suffers from several major weaknesses, that is, it is difficult to verify the mathematical model in the event of an internal leakage of the piston seal due to the nonlinearity resulting from friction from the piston seal [4] [9]. Kalyoncu and Haydim [10] studied the internal leak of electrohydraulic servo - system and applied fuzzy logic to a non-linear mathematical model. J.F.Ortiz [11] implemented a non-

linear mathematical model for position control of normal (no-leak) hydraulic actuator and with an internal leak and by simulations the MATLAB-Simulink by comparing the two signals, the internal leakage can be detected. Z. Shi et. al. [12] Ball adopted a methodology to combine a non-linear model and an adaptive threshold for fault detection in the electro-hydraulic system. This method is characterized by taking into account parameter uncertainties Phanindra Garimella and Bin Yao [13] used the non-linear model relies on adaptive robust observer to overcome the parameter uncertainty problem

1.2 Non-Model based

The model-based approach does not require a mathematical model, but it depends on the information that determines the behavior of the system. In the event that any change in the behavior of the system is observed, it is fault indication Amin Y. G, N.Sabehri [14] application Hilbert – Huang transforms (HHT) on the pressure signal after collected from one-side of the actuator Xiuxu Zhao [15] has designed an instrument for internal leakage detector for actuators by measuring pressure and position and using an arm chip Because of the inability to rely on one sensor signal, Xiuxu Zhao [16] combined the displacement signal and pressure signal based on evidence theory and the application of the BP neural network. There are many researchers was used signal analysis methods. Morgan May and Nariman Sepehri [17] have used cross-correlation time-series analysis of the measured pressure signal. Amin Y. G, Nariman. S [18] made a comparison between fast Fourier transforms and a wavelet transform method on the measured pressure signal and the result was wavelet transforms are better than fast Fourier transforms in detecting faults frequencies Xiuxu Zhao [19] presented a method using measures high and low pressure on both sides of the piston and rod position of hydraulic cylinder and signal processing by wavelet packet analysis. Zhikai Yao [20] used a method based on collecting the pressure signal only from the high-pressure chamber after affecting the control valve with a sinusoidal signal, and converting it from the time domain to time– frequency image using continuous wavelet transform. Goharrizi et al. [21] used wavelet transform (WT) applied to the pressure signal measured inside the cylinder after applying periodic step inputs on the control valve, it was shown that response in the pressure signal when there is an internal leak.

2. Modeling Procedure of the Hydraulic System

With reference to Fig. 1, Applying the continuity equation for extension motion of the cylinder. Where P1 and P2 are the pressures at the high-pressure side and the low-

pressure side of the cylinder respectively. Assume the following:

- The fluid properties are not changed
- The effective bulk modulus βe and the density of the fluid are constant
- The effect of working temperature is negligible during the experiments.

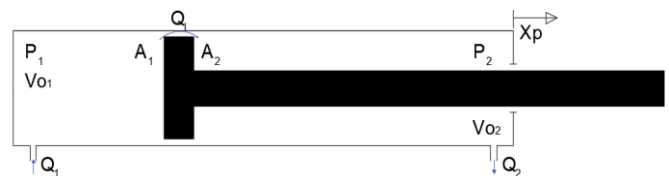

Fig. 1. A schematic diagram of a hydraulic actuator

Applying the continuity equation to each of the high-pressure side and the low-pressure side of the cylinder for extension motion yields

$$Q_1 - Q_L = A_1 \dot{x}_p + \frac{\dot{p}_1}{\beta} (V_{01} + A_1 X_p) \tag{1}$$

and

$$Q_L - Q_2 = -A_2 \dot{x}_p + \frac{\dot{p}_2}{\beta} (V_{02} + A_2 X_p) \tag{2}$$

We can get the internal leakage (Q_L) from Eq. (1) and (2) as follows:

$$Q_L = \frac{1}{2} [Q_2 + Q_1 - \dot{x}_p (A_1 + A_2) + \frac{\dot{p}_2}{\beta} (V_{02} + A_2 X_p) - \frac{\dot{p}_1}{\beta} (V_{01} + A_1 X_p)] \tag{3}$$

Equation (3) represents the system equation. (Internal leakage mathematical models in general). It is evident from the general internal leakage mathematical models that the variables: x_p , P1, and P2 and Their derivatives are sufficient to describe the indicators of fault. Hence, three sensors are sufficient to detect fault. (Two pressure sensors and speed sensor). [22]. From Eq. (1) and (2), one can get relationship between (Q_1) and (Q_2)

$$Q_2 - A_2 \dot{x}_p + \frac{\dot{p}_2}{\beta} (V_{02} + A_2 X_p) = Q_1 - A_1 \dot{x}_p - \frac{\dot{p}_1}{\beta} (V_{01} + A_1 X_p) \tag{4}$$

where Q_1, Q_2 are the flow rates at the high-pressure side and the low-pressure side respectively, is the internal oil leakage flow rate across the seal piston, V_{01} and V_{02} are the initial volumes of oil in the actuator sides, A_1 and A_2 are the areas of the piston head from sides 1 and 2 respectively, X_p and \dot{x}_p are the displacement and the

velocity of the piston rod respectively, β is the bulk modulus of oil.

After extended the actuator to reach the end of the stroke and apply Eq. (1) and (2) we can get as follows: From eq 4. ($V_{02}, \dot{x}_p = 0$) and \dot{p}_1 is very small and can be neglected.

$$Q_2 = Q_1 - \frac{\dot{p}_1}{\beta} (V_{01} + A_1 X_p) \quad (5)$$

From system eq 3

$$Q_L = \frac{1}{2} [Q_2 + Q_1 - \frac{\dot{p}_1}{\beta} (V_{01} + A_1 X_p)] \quad (6)$$

In simple terms, when the piston reaches to the end of the stroke, we can identify and measure amount of internal leakage, that by measuring Q_2 by flow meter sensor.

3. Experimental Procedure

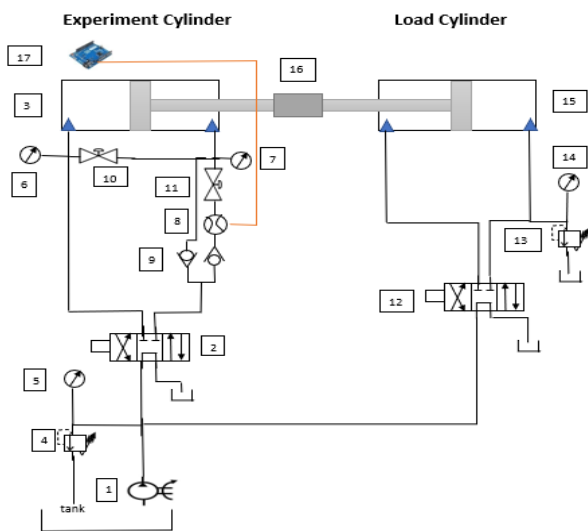

Fig. 2. Experimental test rig

1 - hydraulic gear pump, 2 - 12 direction control valve 4/3, 3 - 15 hydraulic cylinders, 4 - 13 pressure relief valves, 5 - 6 - 7 - 14 pressure gauges 8 - flow meter sensor, 9 - check valve, 10 - bidirectional flow control valve 11 - shut off valve, 16 - connector, 17 - controller (Arduino uno board).

3.1 Experimental test rig consists of:

- 1- A hydraulic pump (5.7 cm), driven motor (1.5 hp, 1400rpm), main relief valve (adj 30 bar) and two cylinders (single acting).
- 2- Main Cylinder contains the following, analog pressure gauge on both sides of moving piston, and bypass between two chambers of the experimental cylinder to simulate different internal leakage by adjusting the opening area of the throttle valve, that is, turning the hand with different scaling, flow control valve (VRFB 140) and flow capacity (25 L/min), flowmeter sensor (OF05ZAT) at rod end port controlled by Arduino uno board and computer. the flowmeter sensor withstands

maximum pressure 12 bar to avoid damaged it due to high pressure, two paths were implemented at rod end port. One of them to return flow with flowmeter sensor and another for high pressure that is by used two non-return valves.

- 3- Load Cylinder consists of relief valve at cap end port that is to constant the load value by constant the pressure inside the cylinder while the experimental cylinder rod is moving.
- 4- Connector between two rods of the cylinders for fixed with together

3.2 Measuring procedure:

It is done as follows;

- 1- Set the pressure relief valve of the load cylinder to a value of 10 bar.
- 2 - Read the pressure on both sides of the piston, measure the flow rate at the rod end port, and measure the linear velocity of a piston, repeat these measurements at different values of leakage (0.3-0.4-0.5-0.6-0.7 l/min) and no leakage (normal system), While extracted piston stroke.
- 3- Measurement the two pressure and linear velocity are enough to detect leakage according to system equation 3 [22]. However, we cannot measure the pressures due to the small change in the measured values with the leakage values by using the analog pressure gauge. Which requires high-precision and expensive measuring devices.

Symbol	Designation	Used value
P_r	Adjust the main relief pressure of system	30 bar
P_l	Load cylinder pressure	10 bar
D	Experimental hydraulic cylinder diameter	50 mm
d_{rod}	Experimental hydraulic cylinder rod	30 mm
L_{st}	Experimental hydraulic cylinder stroke	40 mm

4. EXPERIMENTAL RESULTS

Figure (3) shows the change in the return flow values Q_2 with the time at no leak (normal system).

It can be seen that the piston reaches at the end of the stroke at the tenth-second we find that Q_2 reaches zero, and this means that the cylinder has no leakage according to Equation 6.

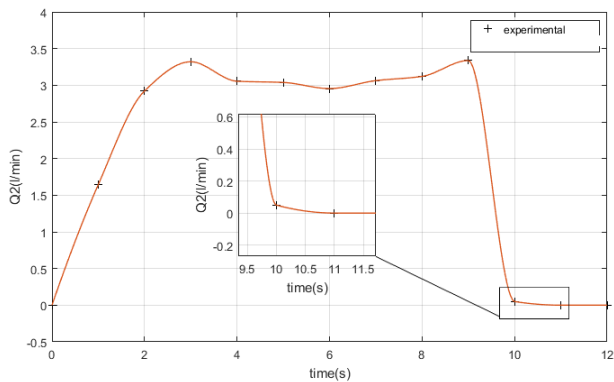

Fig. 3. Q2 versus time at no leak (normal system).

Figure (4 - 8) shows the change in the pressure values Q2 with the time at the change in the leakage values (0.3-0.4-0.5-0.6-0.7 l/min).

One can also note that when the piston reaches the end of the stroke, the value of Q2 is the same as the value of QL. Which can be an indicator of leakage and measure its quantity according to Equation 6.

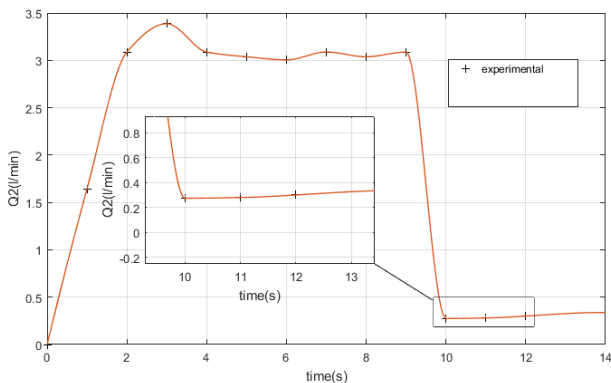

Fig. 4. Q2 versus time at QL max=0.3 L/min.

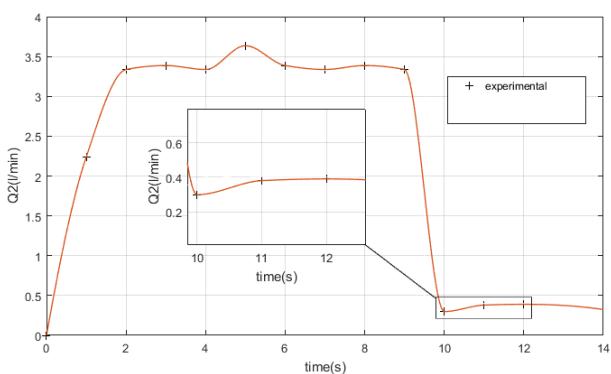

Fig. 5. Q2 versus time at QL max=0.4 L/min.

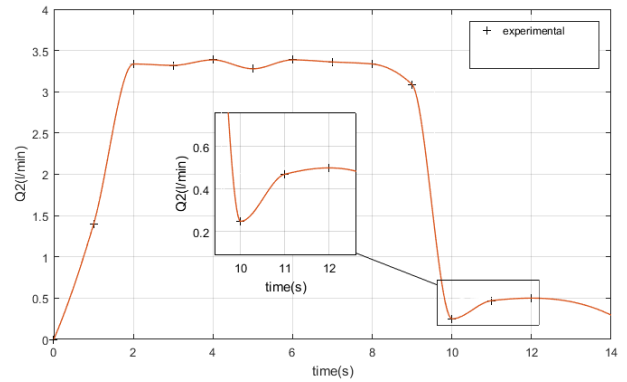

Fig. 6. Q2 versus time at QL max=0.5 L/min.

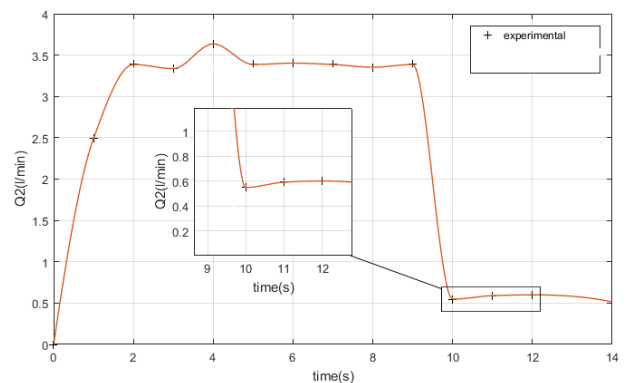

Fig. 7. Q2 versus time at QL max=0.6 L/min.

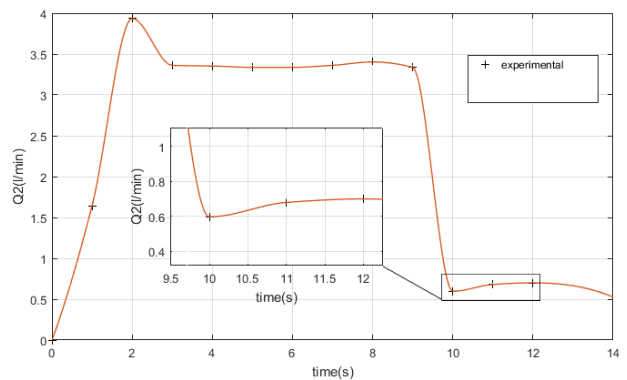

Fig. 8. Q2 versus time at QL max=0.7 L/min.

5. CONCLUSIONS

1. The possibility of measuring and detecting leaks by measuring the flow of return oil at the rod end port during the extended of the hydraulic cylinder without the need of high accuracy measuring devices, with a maximum of 5% errors.
2. The devices used to detect internal leakage fault are cheap, as they use an Arduino board with a flow sensor only.
3. The results can be used to implement an IoT system, after converting the leak into an electrical signal

References:

- [1] Jelali, M. and Schwarz, H. 1995. Nonlinear identification of hydraulic servodrive systems. *IEEE Contr. Syst. Mag.*, Vol. 15, pp. 17-22.
- [2] Isermann, R. 1996. On the design and control of mechatronic systems - A survey. *IEEE Trans. Ind. Electron.*, Vol. 43, pp. 4-15.
- [3] Karpenko, M. and Sepehri, N. 2003. Robust position control of an electrohydraulic actuator with a faulty actuator piston seal, *ASME J. of Dynamic Systems, Measurements and Control*, Vol. 125, pp. 413-423.
- [4] Watton, J. 2007. Modeling, monitoring and diagnostic techniques for fluid power systems, Springer.
- [5] Watton, J. and Pham, D. T. 1997. Fault classification of fluid power systems using A dynamics feature extraction technique and neural networks, *Proc. Instn. Mech. Engrs.*, Vol. 212, Part I, pp. 87-96.
- [6] Tan, H. and Sepehri, N. 2002. Parametric fault diagnosis for electrohydraulic cylinder drive units. *IEEE Trans. Industrial Electronics*, Vol. 49, pp. 96-106.
- [7] An, L. and Sepehri, N. 2005. Hydraulic actuator leakage fault detection using extended Kalman Filter. *Int. Journal of Fluid Power*, Vol. 6, pp. 41-51.
- [8] Shi, Z., Gu, F., Lennox, B. and Ball, A. D. 2005. The development of an adaptive threshold for model based fault detection of a nonlinear electrohydraulic system. *Control Engineering Practice*, Vol. 13, pp. 1357-1367.
- [9] An, L., & Sepehri, N. (2004). Leakage fault identification in a hydraulic positioning system using extended Kalman filter. In *Proceedings of the American Control Conference* (Vol. 4, pp. 3088-3093).
- [10] Kalyoncu, M., & Haydim, M. (2009). Mathematical modelling and fuzzy logic-based position control of an electrohydraulic servosystem with internal leakage. *Mechatronics*, 19(6), 847-858.
- [11] Ortiz, J. F., Borrás, C., & Sepulveda, D. (2019). Fault Detection and Diagnosis for a Nonlinear Hydraulic Actuator. In *IOP Conference Series: Materials Science and Engineering* (Vol. 575). Institute of Physics Publishing.
- [12] Shi, Z., Gu, F., Lennox, B., & Ball, A. D. (2005). The development of an adaptive threshold for model-based fault detection of a nonlinear electro-hydraulic system. *Control Engineering Practice*, 13(11), 1357-1367.
- [13] Garimella, P., & Yao, B. (2005). Model based fault detection of an electro-hydraulic cylinder. In *Proceedings of the American Control Conference* (Vol. 1, pp. 484-489).
- [14] Goharrizi, A. Y., & Sepehri, N. (2012). Internal leakage detection in hydraulic actuators using empirical mode decomposition and hilbert spectrum. *IEEE Transactions on Instrumentation and Measurement*, 61(2), 368-378.
- [15] Zhao, X., Hu, Z., & Shang, Y. (2013). Research on hydraulic cylinder fault diagnosis system based on ARM. In *Advanced Materials Research* (Vol. 619, pp. 489-493).
- [16] Zhao, X. X., Zhou, C. L., Hu, Z. M., & Zhang, W. B. (2013). The research on information fusion methods of leakage failure mode identification of hydraulic cylinder. In *Applied Mechanics and Materials* (Vol. 364, pp. 61-65).
- [17] Morgan May Nariman Sepehri, Witold Kinsner. (2014). HYDRAULIC ACTUATOR INTERNAL LEAKAGE DETECTION USING CROSSCORRELATION TIME SERIES ANALYSIS In *Proceedings of the American Fluid Power Systems and Technology Division Conference* (ISBN:978-0-7918-4597-4).
- [18] Goharrizi, A. Y., & Sepehri, N. (2013). Application of fast fourier and wavelet transforms towards actuator leakage diagnosis: A comparative study. *International Journal of Fluid Power*, 14(2), 39-51.
- [19] Zhao, X., Hu, Z., Li, R., Zhou, C., & Jiang, J. (2014). Internal leakage fault feature extraction of hydraulic cylinder using wavelet packet energy. In *Communications in Computer and Information Science* (Vol. 405, pp. 363-375). Springer Verlag.
- [20] Yao, Z., Tang, J., Rui, T., & Duan, J. (2016). A time-frequency analysis based internal leakage detection method for hydraulic actuators. *Advances in Mechanical Engineering*, 9(1).
- [21] A.Y. Goharrizi and N. Sepehri, "A wavelet-based approach for diagnosis of internal leakage in hydraulic actuators using on-line measurements," *IEEE Transactions on Industrial Electronics*, vol. 57, 10-22, 2009.
- [22] A. El-Betar and M. Abdelhamed and A. El-Assal and R. Abdelsatar, " Fault Diagnosis of a Hydraulic Power System Using an Artificial Neural Network," *JKAU: Eng. Sci*, Vol. 17 No. 1, 117 - 137, 2006.
- [23] Yuuki Aita, Natsumi Asanuma, Akira Takahashi, Hiroyuki Mayama, and Yoshimune Nonomura "Nonlinear friction dynamics on polymer surface under accelerated movement," *AIP Advances*, 05 April 2017
- [24] Xiuxu Zhao "The Research on Information Fusion Methods of Leakage Failure Mode Identification of Hydraulic Cylinder," *Applied Mechanics and Materials* Vol. 364 (2013) pp 61-65.

ACKNOWLEDGEMENT

Financial support from Faculty of Technology and Education, Helwan University and First industrial Development Group, El Obour, Cairo as well as the logistical/moral supports from Mr. Loai Abd El Wahed, Managing Director of First Industrial Development Group, and Mr. Ahmed Hamdy Mansour are acknowledged.

BIOGRAPHIES



Sabry Allam is a Professor of Automotive Engineering, Faculty of Technology and Education, Helwan University (HU), Cairo, Egypt. He received his PhD from the Royal Institute of Technology, Stockholm, Sweden in 2004, while he earned his MSc from Technical University of Turin and HU in 1995. He is specialist in vehicle pollution and noise control and has almost 100 of research papers.



Mossad Atia Ibrahim has BSc in Mechanical Engineering from Helwan University, Cairo, Egypt 2003. Equipment Maintenance Manager at the First Industrial Development Company - El Obour, Cairo.