

# Vehicle to Vehicle charging (V2V)

Sakthi Priyan V<sup>1</sup>, Amanesh Ram M V<sup>2</sup>, Nireesh J<sup>3</sup>

<sup>1</sup>Student, Department of Automobile Engineering, PSG College of Technology, Coimbatore, Tamil Nadu, India.

<sup>2</sup>Student, Department of Automobile Engineering, PSG College of Technology, Coimbatore, Tamil Nadu, India.

<sup>3</sup> Assistant Professor, Department of Automobile Engineering, PSG College of Technology, Coimbatore, Tamil Nadu, India.

\*\*\*

**Abstract** - - People's desire to buy pure battery electric vehicles is hindered by the delayed development of energy storage technology, combined with the limited number of plug-in charging points. Due to the limited number of charging stations available, this technology can be used to expand charging options through vehicle-to-vehicle (V2V) charging. The vehicle-to-vehicle (V2V) wireless charging system offers a flexible and fast energy exchange method for charging electric vehicles (EVs) without the need for charging stations. A new framework for vehicle-to-vehicle wireless charging technology is introduced that can work with or without plug-in electric cars. V2V charging requires overcoming various technological hurdles, including the angular displacement of the resonant coils of wireless power transfer. The mutual inductance of the two resonant coils is an important characteristic for high performance and efficient power transfer.

**Key Words:** *Wireless charging system, vehicle-to-vehicle (V2V) charging, the mutual inductance of the two resonant coils, flexible and fast energy exchange method, charging electric vehicles (EVs)*

## 1. INTRODUCTION

Transportation is an important aspect of our lives, just like food and water. It affects our daily lives, but it must be controlled by intelligent systems; one day in the future it will be completely controlled by things, not people. To improve safety, we need to start and improve V2V and Vehicle-to-Infrastructure "V2I" technologies. Intelligent Transportation Systems (ITS) is a broad and evolving field, with some components converging or overlapping. For example, traffic and travel information can be considered part of the Smart Cities agenda, and similarly "connected cars" are a combination of Machine-to-Machine (M2M) and Internet of Things (IOT) communication, while V2V communication is typically developed as part of Intelligent Transport Systems (ITS)[3].

The implementation of this technology is more environmentally beneficial than the use of fossil fuels, which contribute to the greenhouse effect. This alternative technology is developing rapidly and will soon become the current transportation system. The electric car can be further upgraded to become a self-driving vehicle.

One of the challenges of electric vehicles is the energy management system, which involves charging and discharging the car. Examples of new technologies (V2V) are vehicle-to-grid, smart grid and vehicle-to-vehicle charging. V2V can be particularly useful because charging can happen anywhere without having to travel to a specific charging station; currently there are not as many charging facilities for electric cars as there are for traditional fossil fuel charging stations (gas stations).

The V2V system can be further enhanced by using a wireless charging system in which the source car charges the other vehicle without using a physical wire. Because it does not require stopping or standing still, this wireless charging solution is more promising and efficient. In this study, the concept of wireless charging of a real-time inter-vehicle charging system is discussed.

Wireless technology allows a vehicle such as a bus or an automated vehicle to continue driving; therefore, this system does not interfere with the automatic vehicle planning system. In this study, inter-vehicle charging is replicated using two mobile robots displaying an automated vehicle. This study is a continuation of our previous research that underlies the wireless system. It discusses the concept of an automatic vehicle.

## 1.1 Methodology

### 1.1.1 Existing system

In the existing systems of EV charging grid to vehicle charging is present. Mostly plug-in EV chargers are implemented. Wireless chargers are not yet implemented commercially since plug-in chargers are simple to design and more affordable.

### 1.1.2 Proposed System

Due to limited availability of charging stations, charging of EVs will be a major problem [5]. In case of emergency charging requirements, the availability of grid connected charges is very limited and in case of charge down situations vehicles are unable to move from that spot to the charging stations. For that we propose a wireless charger which serves dual purpose.

- 1.Can charge from grid connected power supply
- 2.Can get wirelessly charged from another vehicle
- 3.Can wirelessly charge to another vehicle

## 2. Transmitter Section

1. The first section [2]of the circuit is the High-Frequency inverter which is designed using SG3525 IC. It produces High Frequency PWM signal. The frequency range is 60 – 75 KHz.
2. The second section is the Half-Bridge Driver circuit [9]which consists of two N-channel MOSFETs. MOSFETs drivers feed the PWM signal to the primary of a HF switching transformer.
3. The third section is the High-Frequency Transformer[11]. It converts the DC DC input fed in the primary coil by the MOSFETS into HF AC output at its secondary coil.
4. The fourth section is the transmitting coil. It converts the fed HF-AC current into electromagnetic waves.[1]

SG3525 IC is basically a PWM oscillator chip which produces high-frequency PWM signal which can drive MOSFETs directly to switch then ON and OFF. The frequency of the PWM signal can be set and also adjusted using the timing control resistor and capacitor which are connected to the pin-6 and pin-5 (RT and CT). The IC has two PWM outputs which are pin-11 and pin-14 (out A and out B)[7]. Two pwm outputs are connected to the gate terminal of MOSFETs connected in half-bridge configuration. Transmitter coil is a centre tapped coil, so it has three terminals. The Drain terminal of the two MOSFETs are connected to two ends of the transmitter coil. Centre tap of the coil is connected to the DC source power supply which is 12v.

When power is turned ON the IC SG3525 starts oscillating and produces PWM signals[7]. The MOSFETs connected to its outputs are switched ON and OFF alternatively. The Out A and Out B of the IC output are 90degrees out of phase. So when one MOSFET is in ON condition the other # will be in OFF condition. Here we use a oscillator frequency of 60 to 80KHz frequency range. So the MOSFETs are switched at high frequency. When on MOSFET is in ON condition the DC current will flow from the centre tap of transmitter coil through MOSFET drain terminal and reach the source terminal which is connected to ground. So in first half cycle the direction of DC current will be in first half coil portion of the transmitter coil. In the same way the current flow will be in second half portion of the coil during next half cycle.

**Table -1:** Testing Observation

Test No	Input Voltage	Transmitted voltage	Received Voltage	Output Voltage
1	12V DC	12V AC	11V AC	11.9V DC
2	12V DC	12V AC	11.97V AC	11.95V DC
3	12V DC	12V AC	12V AC	12V DC
4	12V DC	12.02V AC	12V AC	12V DC

Thus, the two MOSFETs create a current flow which are opposite in direction in each switching cycle. So as a result, an alternating current is produced in the transmitting coil. This configuration thus produces a high frequency AC current from the input DC current. Transmitter coil converts the HF AC electric current into HF electromagnetic field. Thus, the transmitter coil converts electric current and transmits in the form of electromagnetic waves to receiver section [3].

## 3. Receiver Section

Receiver has a three section.

1. First is the receiver coil
2. Second is the High-Frequency rectifier
3. Third is the DC ripple filter

Receiver has a receiving coil which has same resonant frequency of the transmitter coil[3]. So when placed near the transmitter coil it will pick up the electromagnetic field and converts it into the high frequency AC current [6].

Output of receiver coil is given to a high frequency rectifier which converts HF AC to DC voltage output. A capacitor filter at the output of rectifier filters the ripple in DC and gives a stable DC output voltage. A DC output is produced at the output of receiver which is used to power any DC loads.

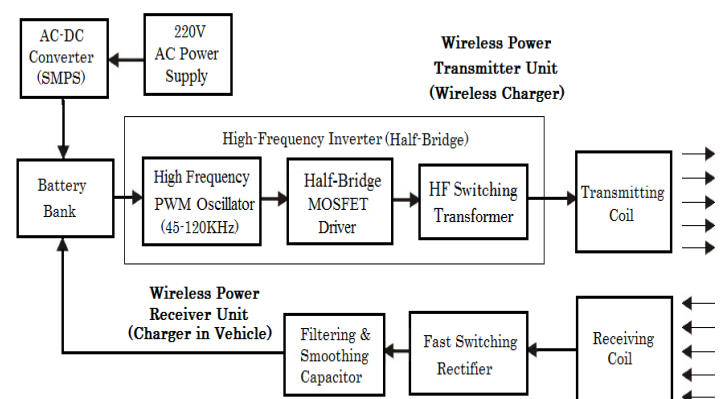

**Fig -1:** Block Diagram

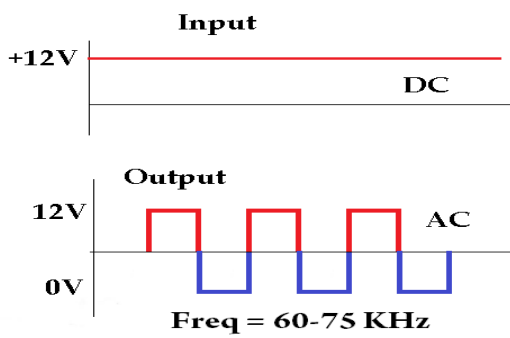

Chart -1: DC to PWM conversion

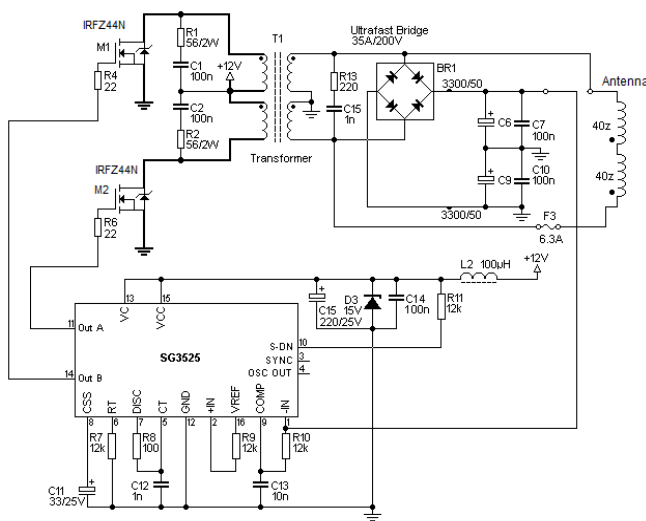

Fig -2: Transmitter Circuit

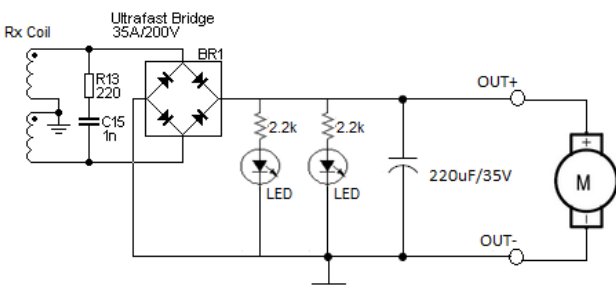

Fig -3: Receiver Circuit

#### 4. CONCLUSIONS

In this project we have introduced a controller that can be used in Wireless EV charging systems to charge electric vehicles without wires. Wireless power transmission works by utilizing the principle of electromagnetic resonance, which is that two copper coils resonate with the same frequency between the transmitter and receiver. The transmitter coil is connected to the battery, which moves the vehicle 1 to charge another vehicle 2. The electrical energy

that comes from the battery makes the copper coil resonate at a particular frequency.

The proposed controller is capable of self-tuning the switching operations of the converter to the resonance frequency of the WPT system, and therefore eliminates the need for switching frequency tuning. Contactless electric vehicle (EV) charging based on inductive power transfer (IPT) systems is a new technology that brings more convenience and safety to the use of EVs. This project proposes a new structure of wireless V2V charging technology that can work together with plug-in EVs charging or operate independently. It can effectively solve the problem of a limited number of plug-in stations, and it can realize mutual power supply between vehicles. One issue with the wireless V2V charging technology is the angular offset due to the change in the location of the vehicle. Therefore, this paper presents the fundamental theory of multi-turn coil design with angular offset.

As the proposed project is a miniature prototype of Vehicle to vehicle charging, the average output we get is 400mA and 12V, which in turn takes 17.5 hours to charge a fully drain 12V 7Ah Battery.

Simulation results show that if the transmitter coil and receiver coil are the same size and closely wound, the system can achieve high mutual inductance. If the size of transmitter coil and the receiver coil are different, the coil will require an optimal design. We quantify the impact of adopting this technology in terms of system-wide energy savings, charging infrastructure requirements, and travel times, and investigate the possibility of reducing battery capacity in EVs as a result of this technology.

#### REFERENCES

- [1] T. Blackwell, "Recent demonstrations of laser power beaming at DFRC and MSFC," AIP Conference Proceeding, Beamed Energy Propulsion: Third International Symposium on Beam Energy Propulsion, vol. 766, pp.73-85, Apr. 2005.
- [2] G. Chattopadhyay, H. Manohara, M. Mojarradi, Tuan Vo, H. Mojarradi, Sam Bae, and N. Marzwell, "Millimeter-wave wireless power transfer technology for space applications," Asia-Pacific Microwave Conference, pp.1-4, Dec. 2008.
- [3] H. H. Wu, G. A. Covic, J. T. Boys, and D. J. Robertson, "A series-tuned inductive-power-transfer pickup with a controllable AC-voltage output," IEEE Transactions on Power Electronics, vol.26, no.1, pp.98-109, Jan. 2011.
- [4] S. P. Kamat, "Energy management architecture for multimedia applications in battery powered devices," IEEE Transactions on Consumer Electronics, vol.55, no.2, pp.763-767, May 2009.

[5] M. Kato and C. -T. D. Lo, "Power Consumption Reduction in Java-enabled, Battery-powered Handheld Devices through Memory Compression," IEEE International Symposium on Consumer Electronics, pp.1-6, 20-23 June 2007.

[6] A. Karalis, J. D. Joannopoulos, and M. Soljacic, "Efficient wireless nonradiative mid-range energy transfer," Annals of Physics, vol.323, no.1, pp.34-48, Jan. 2008.

[7] J. Sallan, J. L. Villa, A. Llombart, and J. F. Sanz, "Optimal design of ICPT systems applied to electric vehicle battery charge," Industrial Electronics, IEEE Transactions on , vol.56, no.6, pp.2140-2149, June 2009.

[8]IEEE-SA Standards Board, "IEEE standard for safety levels with respect to human exposure to radio frequency electromagnetic fields, 3 kHz to 300 GHz," IEEE Std. C95.1, 1999.

[9] N. Tesla,"Apparatus for transmission of electrical energy", US Patent, May 1900, No. 649621.