

DESIGN AND DEVELOPMENT OF RANGE CONTROL FIRE EXTINGUISHING SYSTEM

Isa Shiva Prasad¹, Subbarao Dronamraju², Dr Ritesh Kumar³

^{1,2}Final Year Student, Department of Mechanical Engineering,

³Assistant Professor of Mechanical Engineering,

^{1,2,3}Sathyabama Institute of Science and Technology, Chennai, Tamilnadu, India -600119

Abstract - In this paper, Robotic firefighting system with acute heat detectors and an avoidance function is designed and developed. Circuit design combines a microcontroller needs various parts to complete the task it was programmed to do. The chassis' structural layout accommodates all components for maximum performance. To determine the most effective manner to do the assignment, the codes were modified. The smart fire extinguisher system advanced, per the experimental results. The best response time for the move stop is found to be 400ms, which indicates that the gripper will start putting out the fire and will shut off the water pump after the fire is instantly put out. Similarly, upon the detection of fire and smoke, the SMS messaging capability as well as the fire as well as smoke alarm detection was effectively activated. This efficiently produced robotic firefighting system will be a reasonable precaution against fire calamity.

Key Words: Embedded c software, Warning system, sensors, Arduino, Rescue robot

1. INTRODUCTION

Background of the Study

One of the most important concern was that no organization nor any governing body or no person will be available all the time when there was a fire accidents. Due to high explosives, high smoke and high intensity of fire intensity of fire its impossible for humans to enter the fire place. A Quicker response was needed to avoid huge damage. Any kind of objects which have tendency to generate fire can leads to fire accidents. They are concerns for not only industrial fire but to domestic household due to poor fire management techniques. In present a lot of Fire safety systems and new technologies emerged in market like chemical fire extinguishers, but along with that advancements in the field of robotics and embedded systems things are becoming easy day-by-day. These smart robot systems for extinguishing fire was built in such a way that makes the humans not to loose their life for simple accidents. The compact automated machine (Smart fire extinguisher robot) was designed to achieve work in three stage process. First stage of this was to detect the obstacle (fire) using given hardware. Second stage was to reach the targeted area with the help of high torque motors without getting damaged. Third stage was to

extinguish fire with the suitable mediums for suitable grades with pump system.

Problem statements.

A fire-fighting robot model was designed by TawfiqurRakib and M. A. Rashid Sarkar. It includes of a core region consisting of "Kerosene wood," an LM35 temperature sensor, flame sensor that recognize fire Two wheels are used by the robot to move around. [1] A firefighting robot operated by an android and powered by an Arduino UNO R3 was proposed by S. JakthiPriyanka and R. Sangeetha. The robot is made up of a gas sensor to detect fires, a gear motor and motor drive to move it, a communication module to connect it to an Android device, and a smartphone control module. Sprinklers and a water pump are also employed in this. An open to all software named Arduino package is required to programme and implement the guidelines for the Arduino UNO. [2] A notification system for an automated fire controller robot was proposed by J. Jalani¹, D. Mismam¹, A. S. Sadun¹, and L. C. Hong¹. Three flame sensors are used by this robot to detect fires in the left, right, and center directions. Three ultrasonic sensors are also included for detecting and avoiding obstacles. The robot uses a bluetooth module to send the user a warning notification when it senses a fire. [3]

2. Methodology

An Arduino Mega 2560 microcontroller, to which various sensors are linked, is used to manage the project. Two SLB-1674 7.4V batteries are used in this project to dissipate the necessary and sufficient power to all of the system's components. The project also makes use of four decelerated 280 Revolutions per minute DC motors that, when necessary, can be prolonged to drive up to nine wheels and are managed by an L298 H-Bridge Motor Driver. For the purpose of avoiding obstructions, an ultrasonic sensor was necessary. All of the aforementioned components were linked to their respective bodies and modules where 5 to 12 volts and all of the lines were linked in a common.

3. Hardware implementation

One of the most important components in the creation of a firefighting robot is the hardware. Required sensors, a water pump, a motor driver, a tiny bread board, motors, and

wheels are all included. the firefighting robot's block diagram, which shows one IR flame sensor as the system's input. As a micro-controller for connecting additional components, Arduino UNO is used. The L293D Motor Driver is utilized to rotate motors and has the ability to simultaneously run two DC motors.



Fig -1: Aurdino Uno

3.a.Flame Sensor

The flame sensor monitors the ambient and finds any fire present. The module, which was based on an IR transmitter, seek for combustibile and hazardous gases includes nitrogen, hydrogen, and carbon monoxide. The potential for signal detection is customizable. Three flame sensors are on the robot.

3.b.Module for a flame sensor

The pin arrangement of the sensor is shown below. The four pins below are among its four total pins. When this module is paired with a microcontroller unit, the pins are linked.

Voltage supply ranges from 3.3 to 5.3 volts for pin 1 (VCC pin),

pin 2 is a ground pin, and pin 3 is an analogue output slot pin

Pin 4 was a pin for digital output

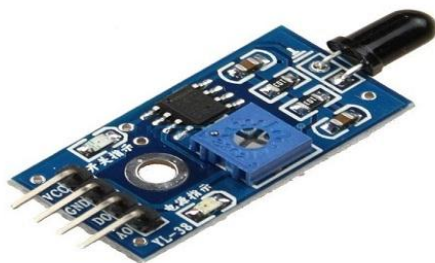

Fig -3: Flame sensor

3.c.Motor Driver L293D

The DC motor's ability to move in either direction is controlled by the L293D motor driver or motor driver IC.

Through the 16-pin IC L293D, we may simultaneously drive two DC motors in either direction.

Features:

1. It is possible to utilise the same integrated circuit to drive two direct current motors.
2. It is possible to alter acceleration ,velocity and distance
3. 4.5 to 36 volts for motor voltage Vcc2 (Vs)
4. 1.2A is the optimum motor current peak
5. 600 micro Amphere is the theoretical optimum motor current
6. 4.5 to 7 as the supply energy to Vcc1
- 7.changing in period: 300 ns (at 5Vand 24V)
8. There was an alternative for thermal shutdown.

L293D Integrated circuits usage:

The L293D is a well-liked 16-Pin Driver Integrated Circuit. Frequently used in motordrives of chips, as the names suggest. Two Direct Current motors can be driven synchronously by a single L293D Integrated circuit, and each motor's direction can be independently evolved . Therefore, this Integrated circuit will be the best choise for you if you have motors that runs at minimum of 36V energy and lower than 600milliAmpheres , and that are to be used by digital circuits like Op-Amp, other circuits, digital gates, or even Micro rollers like PIC, ARM, etc

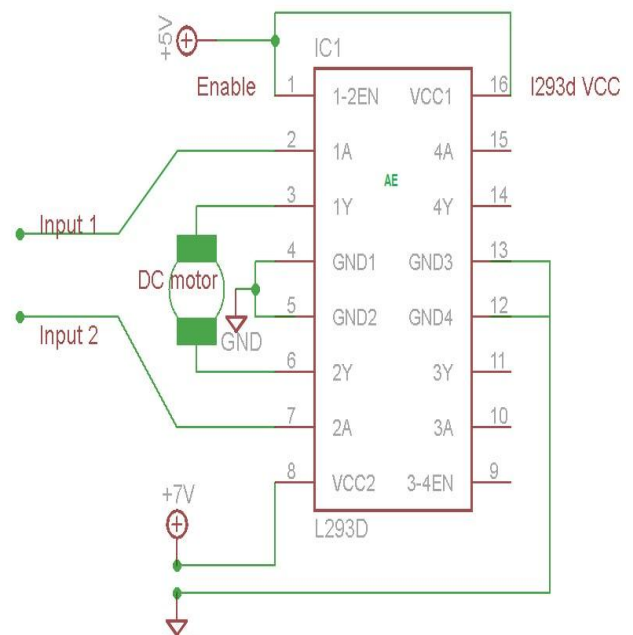

Fig -5: L298D Pin Configuration connections

3.d. Submersible Water Pump

Pump for Submersible Water. For creating an Arduino-based autonomous watering system, submersible water pumps are perfect. The robot's water pump is a crucial component since it will pump with water to douse the fire. A pump that can be substantially submerged in water is a submersible pump, often known as an electric submersible pump. The pump's body and motor are closely interwoven and hermetically sealed. A submersible pump, which translates rotary energy into kinetic energy and pressurized energy, propels water to the surface. This is executed by drawing water into the pump twice: first, at the intake, where the impeller's rotation propels the liquid through the diaphragm. From there, it climbs to the surface.



Fig -5: Submersible pump

Ultrasonic Sensors

Ultrasonic sensors are tools for measuring the distance between a object and the sensor by using ultrasonic waves to convert electrical energy into mechanical energy. The series of longitudinal mechanical waves known as ultrasonic waves travels across a material. of rarefactions and compressions occur along the wave's path. Ultrasound refers to any longitudinal sound wave that is above the human aural range of 20,000 Hz. The frequency range has been mainly categorized based on the type of use, as indicated in the figure below

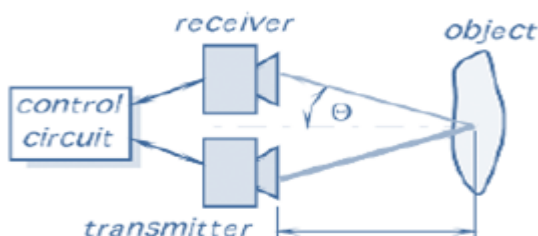

Fig-6 Ultrasonic sensor working

The Frequency Ranges of the Sound

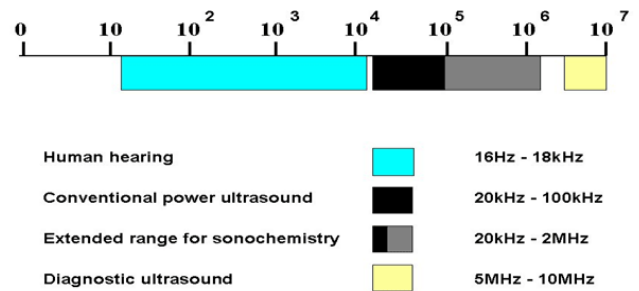

Fig-7 Frequency Band

Ultrasonic Wave Production

The movement of a surface, such as a diaphragm, is necessary for the formation of these mechanical waves because it can cause compression and rarefaction in the medium in front of it. Ultrasonic waves can be produced at frequencies between 1 and 20 MHz and 20 and 40 kHz using magneto strictive and piezoelectric materials acting in the motor mode, respectively.

4. Impression of Hardware and Software

- **Cross-platform** - Cross-platform – The Arduino Software is useful with kali Linux, Mac OS, and Windows operating system. The majority of microcontroller systems are Windows-only.
- **Easy-to-use coding environment** - The Arduino Software is easy enough for intricate users to apply while still being simple and straightforward for newcomers. It's built on the Progressed programming environment, which is helpful for both pupils and mentors learn how to operate.
- **Open source customizable software** - The Arduino software is available as open source tools that occasional programmers can modify. C++ libraries are used to elaborate the language, and anyone can switch to avr programme for more tech details. Similar to that any individual can write the avr code directly in the aurdino directly.
- **Open source adaptable hardware** - Since the blueprints for the boards are made publicly available under a Creative Commons licence , qualified circuit designers may change and expand them to construct their own versions of the module.

5. Problems & Concerns

However, not all issues are present with ultrasonic sensors. As a medium's temperature rises, so does the speed of sound within it. As a result, even though the object has remained in

the same location, it can now appear to have moved closer to the sensor. Air currents may disrupt the wave's passage for a variety of reasons, which could result in "Missed Detection" or incorrect measurement. Acoustic noise, such as high-pitched noises produced by valves and pneumatic devices whistling or hissing at frequencies near to the working frequency, may interfere with the sensor's output. The performance of the sensor is also affected by electrical noise. These could produce artefacts that don't accurately depict the photographed object. Ultrasonic devices feature a "dead zone" where the sensor cannot accurately take measurements, much as how eyesight begins to blur when an item is too close to the eye for the eyes to see it. This occurs as a result of a phenomenon known as ringing, which is the transducer's continued oscillation after emitted the pulse. Because of this, when the distance is too close, the transducer is unable to distinguish between vibration brought on by incident radiation and oscillation brought on by electrical excitation. The risks posed by ultrasonic waves are likewise well established. Too much intensity can heat up human tissues and possibly trigger ruptures in those who are exposed to it.

6. Applications

The issues with ultrasound sensors have been the subject of research, especially in the field of medical imaging where ultrasound is used. It is possible to distinguish between solid and cystic tissues by categorizing tissues using ultrasonic sensor distortions like Acoustic Shadowing and Acoustic Enhancement.. Ultrasonic rangefinders are frequently used in robotics for mapping and distance ranging. Ultrasonic sensors are used in hair styling, such as hair extension implants, even in the fashion business.

Domain	Parameter	Applications
Time taken	Tile-of-Flight, Velocity	Density, Thickness, Flaw Detection, Anisotropy, Robotics, Remote Sensing etc.
the reduction of the force	fluctuations in the signals that are reflected and sent	Microstructures, defect characterisation, and interface analysis
Frequency cycle	Ultrasonic and electromagnetic spectroscopy	Phase analysis, grain size, porosity, and microstructure.
photograph	Time-of-accent, velocity, force reduction mapping in Raster C-Scan or SARs	Density, velocity, 2D and 3D imaging, as well as surface and interior defect imaging.

Table-1 Application of hardware

The issues with ultrasound sensors have been the subject of research, especially in the field of medical imaging where ultrasound is used. It is possible to distinguish between solid and cystic tissues by categorizing tissues using ultrasonic sensor distortions like Acoustic Shadowing and Acoustic Enhancement. The industry has also benefited from the use of ultrasonic sensors in systems for assisted parking, remote sensing and telemetry, cleaning jewellery, plastic welding, and other applications. Ultrasonic rangefinders are frequently used in robotics for mapping and distance ranging.

Support for Third-Party Hardware : You can add support for third-party hardware to your sketchbook directory's hardware directory. Board definitions, core libraries, represents a complex, and programmer definitions are examples of platforms that might be installed there and display in the board menu. Create the hardware directory before installing, and then unzip the third-party platform into a separate sub-directory. (If you name the sub-directory "uno," the Arduino platform that is already built-in will be overridden.) Simply deleting its directory will uninstall it. See the Arduino Platform specification for information on how to create packages for third-party hardware.

3. CONCLUSIONS

This Smart Fire Extinguishing Robot is capable of setting of small industrial fires . The project aims to build a compact firefighting roboting system with some smart features With pumping mechanism and Nozzle system to set off hustle free extinguishing . Usage of more hardware makes the system complex and requires more power to run such a system so, this system was made of basic hardware and in a way more compact manner. Firstly, the basic job of this system was to detect both the fire and obstacle simultaneously. Secondly, the system can be navigated with the help of programme written on it or manually through controller. Finally, when fire is detected then it is sets it off with the help of pump and nozzle system mechanism.

REFERENCES

- [1] Tawfiqur and M. A. Rashid Sarkar Design and fabrication of an autonomous fire fighting robot with multisensor fire detection using PID controller,2016
- [2] S. Jakthi Priyanka,R. Sangeetha, "Android controlled firefighting robot",Inernational journal of innovative science Engg. and Technology ,Volumn 3, 2017.
- [3] H.K. Anandakumar and A bio-inspired swarm intelligence method for socially aware cognitive radio handovers, Umamaheswari, Computers & Electrical Engineering, vol.71, pp. 925-937, Oct.2018.doi:10.1016/j.compeleceng .2017.09.016

- [4] Early Detection of Lung Cancer Using Wavelet Feature Descriptor and Feed Forward Back Propagation Neural Networks Classifier, Lecture Notes in Computational Vision and Biomechanics, 103–110, 2018, doi:10.1007/978-3-319-717678_9.
- [5] "Fire Extinguishing Robot," International Journal of Advanced Research in Computer and Communication Engineering, 5(12), December 2016. Nagesh M. S., Deepika T. V., Stafford Michahial, and Dr. M. Shivakumar.
- [6] Autonomous Fire Detecting and Extinguishing, by Chhaya Khandelwal, Saurabh Hisvankar, and Mukul Diwanji Robot, Manipal University Jaipur, September 28-29, 2019
- [7] Control of an Autonomous Industrial Fire Fighting Mobile Robot by HP SINGH, Department of Mathematics, Sri Venkateswara College, University of Delhi.
- [8] An Autonomous Firefighting Robot Real Time Man-Robot Control of a Group of Specialized Mobile Robots Vassil Sgurev, Stanislav Drangajov, Lyubka Doukovska Institute of Information and Communication Technologies, 1113 Sofia.
- [9] A System Architecture of Wireless Communication for Fire- Fighting Robot by Korea Advanced Institute of Science and Technology (KAIST), 335 Gwahangno, Yuseong-gu, Daejeon 305- 701, Republic of Korea.
- [10] Develop a Multiple Interface Based Fire Fighting Robot by 1Department of Electronic Engineering WuFeng Institute of Technology Ming-Hsiung.
- [11] FIRE FIGHTING ROBOT Sahil S.Shah1, Vaibhav K.Shah2, Prithvish Mamtora3 and Mohit Hapani4 1,2,3,4D.J.Sanghvi College of Engineering, Vile Parle – West, Mumbai, India.
- [12] According to 2001, the Jentsch and White Fire generates changes that are natural, unavoidable, and impact all levels of an ecosystem
- [13] S.Boopalan, R. Kumar Narayanan, C. SwarajPaul, G. Narendra Prasad,
- [14] Firefighting robot with gas sensors and a vision camera, Anandan, G. Narendra Prasad International Journal of Engineering and Technology, 2018.
- [15] D.J. Pack, A.M. Mankowski, and G.J. Freeman, A FireFighting Robot and Its Impact on Educational Outcomes.
- [16] T. AlHaza,A. Alsadoon,Z. Alhusinan,M. Jarwali,K. Alsaif. New Concept for Indoor Fire Fighting Robot[. ElsevierLtd,2015,195 .
- [17] Jiangping Fang . Research progress of fire fighting robot [J]. Fire Fighting today.2020 .
- [18] K. Altaf, A. Akbar and B. Ijaz, "Design and Construction of an Autonomous Fire Fighting Robot," 2007 International Conference on Information and Emerging Technologies, Karachi, 2007.
- [19] J. Suresh, "Fire-fighting robot," 2017 International Conference on Computational Intelligence in Data Science(ICCIDS), Chennai, 2017.
- [20] J. S. C. Bose, M. Mehrez, A. S. Badawy, W. Ghribi, H. Bangali and A. Basha, "Development and designing of fire fighter robotics using cyber security," 2017 2nd International Conference on Anti-Cyber Crimes (ICACC), Abha, 2017.
- [21] S. Dearie, K. Fisher, B. Rajala and S. Wasson, "Design and construction of a fully autonomous fire fighting robot," Proceedings: Electrical Insulation Conference and Electrical Manufacturing and Coil Winding Conference (Cat. No.01CH37264), Cincinnati, OH, USA, 2001.
- [22] Tushar Nandkishor Satbhai, R.M.K., Anant Vijay Patil, Manish Patil, Fire Fighting Robot. International Journal on Recent and Innovation Trends in Computing and Communication (IJRITCC), 2016.
- [23] J. Raju, S. S. Mohammed, J. V. Paul, G. A. John and D. S. Nair, Development and implementation of arduino microcontroller based dual mode fire extinguishing robot, IEEE International Conference on Intelligent Techniques in Control, Optimization and Signal Processing (INCOS), 2017.
- [24] Kim, J.-H., S. Jo, and B.Y. Lattimer, Feature Selection for Intelligent Firefighting Robot Classification of Fire, Smoke, and Thermal Reflections Using Thermal Infrared Images. Journal of Sensors, 2016. 2016.
- [25] Harik, E.H. and A. Korsaeath, Combining Hector SLAM and Artificial Potential Field for Autonomous Navigation Inside a Greenhouse. Robotics, 2018.