

Fast Charging of Electric Vehicle using an IOT Appliances

D Priyanka Valli¹, P Blessi Swarupa², T Akhil Sai Mruthyumjayudu³, Ravindra Janga⁴

Dept. of EEE, Bapatla Engineering College, Andhra Pradesh, India

Abstract: Electric vehicle (EV) has achieved incredible interest from the past two decades as it is one of the hopeful greenhouse gases solutions. The number of Electric Vehicle (EV) is increasing around the world; hence that making EVs user friendly becomes more important. The main challenge is usage of EV is the charging time required for the batteries used in EV. As a consequence, this subject matter has been researched in many credentials where a wide range of solutions have been proposed. However, these solutions are in nature due to the complex hardware structure. To provide an unswerving journey an Android application is aimed at giving relevant information about the EV's battery state of charge (SOC) through IoT. The Atmega328 board has been used for the hardware part. The hardware results are confirming the conceptual of the proposed work.

Keywords: Fast charging, Atmega328P, Internet of things.

1. INTRODUCTION

Traditional cars produce a lot of carbon dioxide (CO₂) emissions that are ejected into the atmosphere, causes pollution and greenhouse gases [1]. Today, electric vehicles (EV's) have received much attention as an alternative to traditional vehicles. The traditional vehicle is powered by internal combustion engines. The electric vehicle is developed because of the advancement in battery technology and motor efficiency. The secondary batteries are the main energy sources of the EV. Thus, energy management is the key factor in EV or Hybrid Electric Vehicles (HEV) [2] design. Moreover, the charge capacity of the battery will influence the endurance of electric vehicles. The main challenge in the HEV is the charging time required for the batteries and insufficiency of charging stations (CS) [3] and therefore charging within Traditional cars produce a lot of carbon dioxide (CO₂) emissions that are ejected into the atmosphere, causes pollution and greenhouse gases [1]. Today, electric vehicles (EVs) have received much attention as an alternative to traditional vehicles. The traditional vehicles are powered by internal combustion engines. The electric vehicle is developed because of the advancement in battery technology and motor efficiency. The secondary batteries are the main energy sources of the EV. Thus, energy management is the key factor in EV or Hybrid Electric Vehicles (HEV) [2] design. Moreover, the charge

capacity of the battery will influence the endurance of electric vehicles. Fast charging gives high rating for a vehicle. Due to capacity of charging and battery rate it can easily determine the fast charging. Magnetic mechanism will undergo to occur fast charging for a vehicle in various sector of modes.

2. SYSTEM OVERVIEW

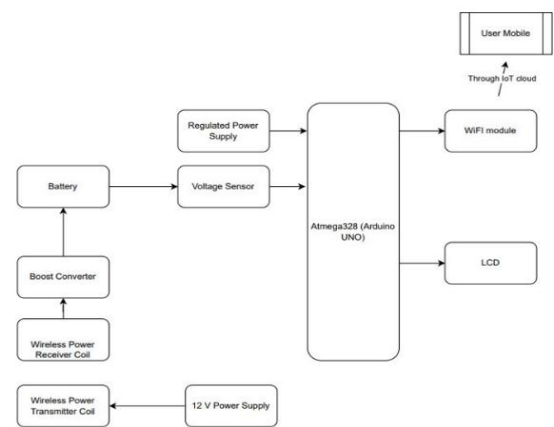

Figure1: Block diagram for fast charging of EV using IOT

Here the operation is working by using an ARDUINO software (IDE) contains a text editor for writing code which is designed for the use of fast charging applications. When the supply is switched ON, the current flows through the sender coil which produces flux in contact with the receiver coil. The flux generated by the coils produce the voltage and it passes through a boost converter. The voltage then flows through a USB source and charges the Lithium-ion battery and a load connector is connected to the USB source. The voltage then flows through an USB source and charges the Lithium-ion battery and a load connector is connected to the USB source.

A pc or laptop adapter is connected to the Arduino board for energy purpose and working of the code. An app or application of Thing speak shows the battery performance and current battery voltage and charging battery voltage at the same time. From this we can observe the performance of fast charging of battery. Here the load is connected across the battery to know that the battery is in charging and discharging

condition while using the load. Here ATmega328P microcontroller is used to dump the code. We need to program the controller and that is done by writing the appropriate program file in the ATmega328P FLASH memory. After dumping this program code, the controller executes this code and provides appropriate response.

3. MODES OF OPERATION

Case1: No Charging Mode

When coils are far away, the flux production is reduced. Hence due to that no charging will occur. In simple way it was disconnection mode.

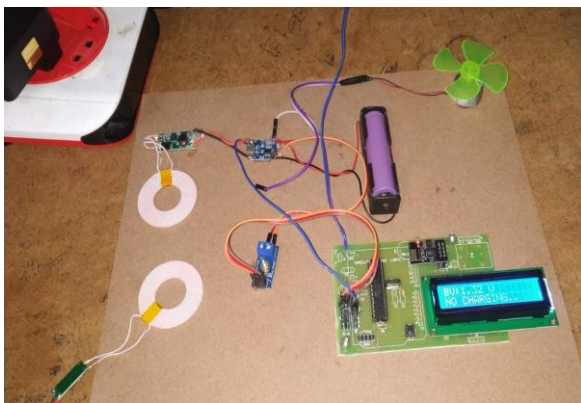

Figure 2: Pictorial representation of no charging mode.

Case2: Charging Mode

When coils are near close to each other the flux production will develop. Hence due to that normal charging will occur. It acts as normal mode of charging.

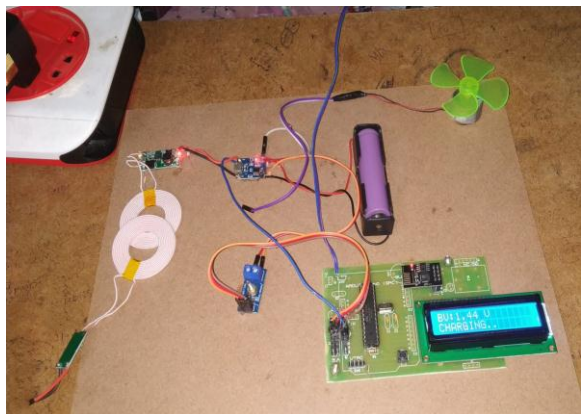

Figure 3: Pictorial representation of charging mode.

Case3: Fast Charging Mode

When coils are very close to each other the flux production will be more as magnetism undergoes. Hence due to that fast charging will occur. It acts as fast mode of charging for vehicle.

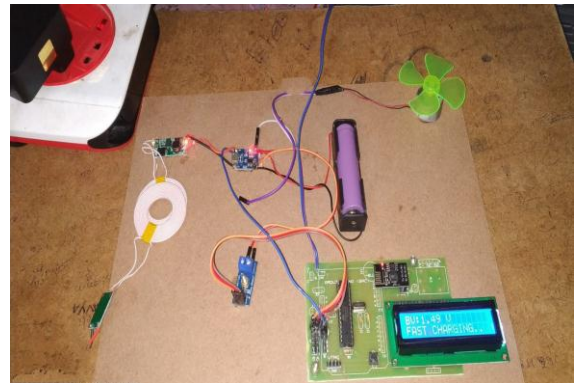

Figure 4: Pictorial representation of fast charging mode.

4. HARDWARE DESCRIPTION

4.1. LCD 16*2 Pin Configuration

- ▶ The term LCD stands for the liquid crystal display. These displays are mainly preferred for multi-segment light-emitting diodes and seven segments.
- ▶ A 16x2 LCD has two registers like data register and command register. The RS (register select) is mainly used to change from one register to another.
- ▶ The main function of the command register is to store the instructions of command which are given to the display.
- ▶ So that predefined tasks can be performed such as clearing the display, initializing, set the cursor place, and display control.

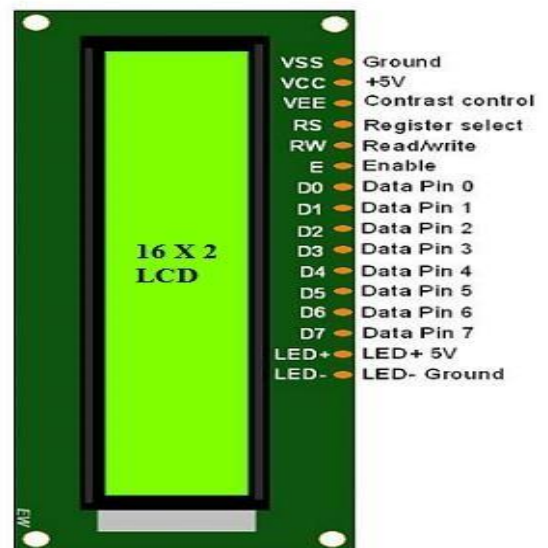

Figure 5: LCD 16*2 Pin diagram features.

4.2. ATmega328P Microcontroller

ATmega328 is high performance, low power controller from Microchip.

It is an 8-bit microcontroller based on AVR RISC architecture it is the most popular of all AVR controllers as it is used in ARDUINO boards.

In ATmega328 chip the code was injected by IC damper. Controller simply executes the program provided by any instant the program(code) will damp in flash memory of ATmega328 the controller executes the code and as result it gets appropriate response.

ATmega328 Features	
Sr. No	Features
1	Non programmable data and program memory
2	High performance
3	Low power consumption
4	Fully static operation
5	On chip analog comparator
6	Advance RISC architecture
7	32KB flash memory
8	2KB SRAM

Figure 6: ATmega328p micro-controller features.

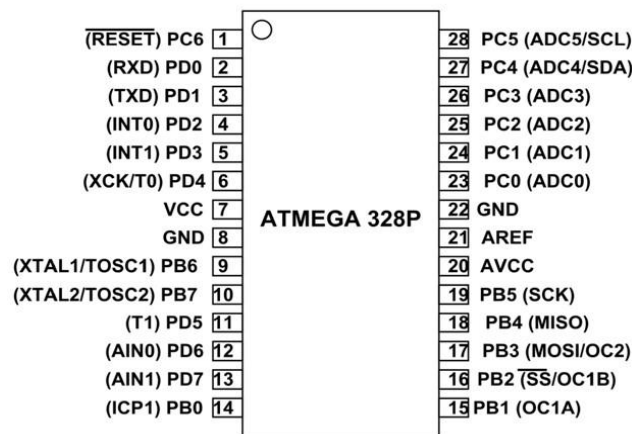

Figure 7: ATmega32 Pin diagram configuration.

4.3. WIFI Module (ESP8266)

ESP8266 was designed by the Chinese company Express if Systems for the uses in Internet of Things (IoT) systems. ESP8266 is a complete WIFI system on chip that incorporates a 32-bit processor, some RAM and depending on the vendor between 512KB and 4MB of flash memory. This allows the chip to either function as a wireless adapter that can extend other systems with WIFI functionality, or as a standalone unit that can by

itself execute simple applications. The chip generally comes as part of a module, soldered to a Printed Circuit Board (PCB), however it is possible to purchase only the chip itself in order to create a truly custom module. The amount of programmable memory varies depending on the module manufacturer, but generally ESPs come with either 512KB, 1MB, 2MB or 4MB of flash memory.



Figure 3.8 Olimex MOD-WIFI-ESP8266-DEV module used in this thesis

The module used in this thesis is an oilmen MOD-WIFI-ESP8266-DEV with all of the basic components of ESP8266, a PCB antenna, crystal and an easily accessed UART with support for SPI and I2C, 2Mbytes of flash, but more importantly for this thesis it has all the available chip pins mapped out for easier access.

5. SOFTWARE DESCRIPTION:

5.1. Algorithm

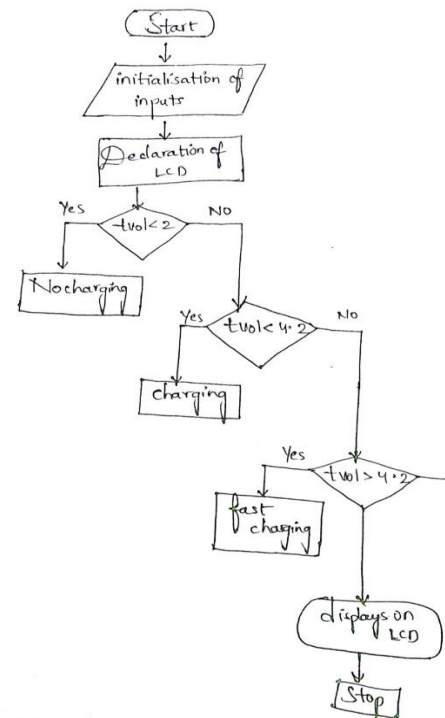

Figure 8: Algorithm used in ATmega328p

5.2. ARDUINO IDE:

The Arduino Integrated Development Environment- or Arduino Software (IDE) – contains a text editor for writing a code, a message area, a text console, a toolbar with buttons for common functions and a series of menus. It connects to the Arduino and Genuine hardware to upload programs and communicate with them

WRITING SKETCHES

Programs written using Arduino Software (IDE) are called sketches. The editor has features for cutting/pasting and for searching/replacing text. The message area gives feedback while saving and exporting and also display errors. The console displays text output by the Arduino software (IDE), including complete error messages and other information. The bottom right-hand corner of the window displays the configured board and serial port. the toolbar buttons allow you to verify and upload programs, create, open and save sketches, and open the serial monitor.

Thing Speak IoT Platform

Thing Speak IoT platform for user to gather real-time data; for instance, climate information, location data and other device data. Thing Speak can integrate IOT-bit, and other software/hardware platforms. Through this you can upload sensors data to Thing Speak. (e.g., temperature, humidity, light intensity, noise, motion, raindrop, distance and other devices information).

RESULTS:

Here we have used an android based IOT application and simple sources for fast charging of electric vehicle by using the lithium-ion battery instead of electric vehicle and the load. The battery gets charged when the wireless coils are placed close to each other. The charging performance and battery performance can be observed through an IOT application APP called Thing Speak which can shows the performance of the battery by using internet.

BATTERY PERFORMANCE:



Figure 9: Graphical representation of battery voltage rate.

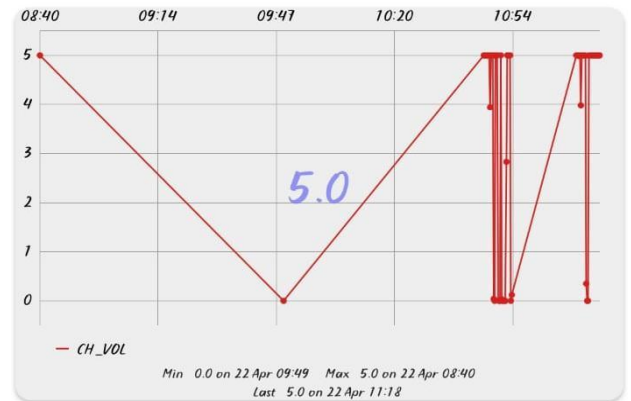

Figure 10: Graphical representation of charging capacity rate.

CONCLUSION:

The main aim is to develop fast wireless charging of EV and an android application for the electric vehicle users. It mainly concentrates on measuring the battery state of charge. After measuring the SOCs it must be communicated to the android application via IoT.

REFERENCES:

- [1] A.Y. Saber and G.K. Venayagamoorthy, –Plug-in vehicles and renewable energy sources for cost and emission reductions||, IEEE Trans. Ind.Electron., vol. 58, no. 4, pp. 1229–1238, Apr. 2011.
- [2] M.A. Hannan, F.A. Azidin, A. Mohamed, –Hybrid Electric vehicles and Their Challenges||, Renewable and Sustainable Energy Reviews 29 (2014) 135–150.
- [3] Arancibia, A. and Strunz, K., “Modeling of an Electrical Vehicle Charging Station for Fast DC Charging||, Proc. IEEE Int. Elect. Veh.Conf. (IEVC), pp. 1-6 2012.
- [4] Praveen Kumar and Kalyan Dash, –Potential Need for Electric Vehicles, Charging Station Infrastructure and its Challenges for the Indian Market||, Advance in Electronic and Electric Engineering. ISSN 2231-1297, Volume 3, Number 4 (2013), pp. 471-476.
- [5] Wenbo Shi, Eun-Kyu Lee, Daoyuan Yao, Rui Huang, Chi- Cheng Chu, and RajitGadh, “Evaluating Microgrid Management and Control with an Implementable Energy Management System”, Smart Grid Energy Research Center University of California, IEEE International Conference on Smart Grid Communication 3-6 November2014.
- [6] M. Verbrugge, D. Frisch, and B. Koch, –Adaptive Energy Management of Electric and Hybrid Electric Vehicles||, Journal of Power Sources, 2005.

[7] Minghao AI, Linhai QI, –Orderly Charging Based Electric Vehicle Charging Stations' On-Line Monitoring System]], CIRED Workshop - Rome, 11-12 June 2014.