

# Semi-Automated Control System for Reaching Movements in EMG Shoulder

R. SIVARAND<sup>1</sup>, B.SANJAY<sup>2</sup>, S. ASHARAF HAMEED<sup>3</sup>, D. KARTHIKEYAN

<sup>1</sup>(COORDINATOR) (Sivarard eee @dvmqrdu.ac.im), <sup>2</sup>(181031101032) BMI (sanjayrock12172@gmail.com),  
<sup>3</sup>(181091101002) EEE(hameedashraf143@gmail.com), <sup>4</sup> (181091101026) EEE (psycactive555@gmail.com)

\*\*\*

**Abstract:** To quickly finish a work while minimising the user's operational failure, a sway system for electromyographic shoulder disarticulation (EMG-SD) restoration was developed. **Methods:** In the motion design of association EMG-SD restorative, machine-controlled victimisation collected visual data using a mixed reality device. The user's electromyogram was used to detect the linked object to be grabbed and to carry out the motion, giving the system voluntary control and making it semiautomatic. To match the performance of the conventional system when it was solely employed to handle the user's visual feedback, two analytical tests were conducted. The proposed system will achieve reaching movements more quickly and precisely than a traditional method. With a discount within the operational failure of association EMG SD restorative user, the planned system achieves a high task performance.

## Statement of Impact:

*In comparison to a traditional system, the recommended semi-automated control system reduced the time required for a reaching movement and increased the number of successful reach-to-grasp procedures.*

## I INTRODUCTION

A shoulder disarticulation prosthesis is used to reconstruct the function and appearance of the arm in people who have lost an upper limb, particularly a shoulder, owing to an accident or congenital problem. Because a body-powered shoulder disarticulation prosthesis requires alternative physical movements of the user, an electric shoulder disarticulation prosthesis driven by actuators is an area of focus [1]. Among them, an electromyographic shoulder disarticulation (EMG-SD) prosthesis, which uses the user's myoelectricity as a control input, can be operated intuitively using biological signals [2]-[6]. Compared with an EMG prosthesis for forearm amputees, an EMG-SD prosthesis has many movable body parts, that is, many degrees of freedom (DoFs) in terms of control.

Therefore, both the hardware and control methods of an EMG-SD prosthesis face numerous challenges.

The well-known EMG-SD prostheses, Luke Arm [3] and Proto2 [4], developed by DARPA, allow for EMG-based manipulations of the arm with many degrees of freedom, which requires targeted muscle reinnervation (TMR) surgery [71-11]. TMR surgery is a procedure that reconnects the peripheral nerve at an amputation stump to the remaining muscles of the trunk. Because the EMG information related to the arm and hand can be measured at the trunk of the body, the arm movements of an EMG SD prosthesis can be controlled by a pattern recognition-based control method [12] [17]. However, the need for surgery and the time required for postoperative rehabilitation may place a heavy burden on EMG-SD prosthesis users [18], [19].

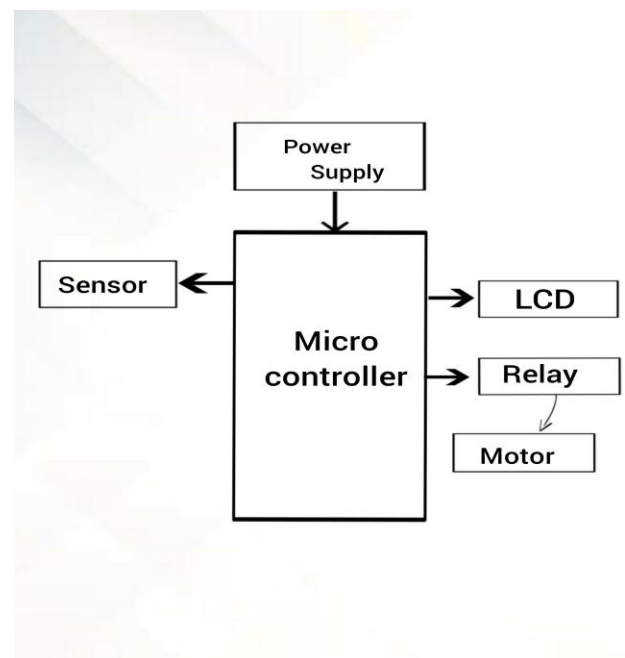

Shows an overview of the proposed control system for a shoulder disarticulation prosthesis based on electromyography. The user looks at an object to be gripped before entering a user interface operational EMG signal taken from his or her own temple. As visual information, the MR device measures the linear distance to the object to be gripped as well as the user's head tilt. BLE communication is used to send the measured visual data to a sub-microcomputer. The sub-microcomputer calculates the target shoulder angle and transmits a command through serial transmission to the main microcomputer. The main-microcomputer actuates a robotic arm and executes the reaching movement when the user enters a motion operational EMG signal measured from his or her own trunk. Controllability based on an EMG signal, which is an intuitive biological signal

## II METHODS

We propose a semi-automated control system for reaching movements in an EMG-SD prosthesis using an MR device. The control system acquires the visual information by using the MR device instead of the user and utilizes it as one of the control inputs. By using the acquired visual information, the proposed control system can eliminate the slow visual feedback loop for the EMG-SD prosthesis user and can achieve a fast pseudo-feedforward control to reduce the operational failure of the user. In addition, the proposed system automatically plans the motion of the EMG-SD prosthesis arm based on the visual information acquired to simplify the operational procedures.

Fig. 1 shows an overview of the proposed control system for the EMG-SD prosthesis. As a control target, we used a simple EMG-SD prosthesis developed by our research group [6]. HoloLens (Microsoft, USA) was used as the MR device to measure the visual information of the external environment. The main-microcomputer (SH72544R, Renesas Electronics Corp.

Japan) controls the 2-DoF arm and the 2-DoF hand by measuring the EMG from the trunk of the user as control inputs. The visual information acquired from the and the EMG from the temple of the user are sent to a sub-microcomputer Cypress Semiconductor Co., USA) for target detection and motion planning. In this study, the HoloLens device acquires the linear distance to the object to be grasped as visual information. Moreover, the rotation of the user's head is captured by the inertial measurement unit (IMU). Thus, the MR device can detect the position of the object to be grasped in a 3D user coordinate system. The target trajectory determined from the acquired visual

information is sent from the sub-microcomputer to the main microcomputer to control the robotic hand and robotic arm. The proposed system calculates the target shoulder angle as the target trajectory. Then, the robotic shoulder is moved to the target shoulder angle while the control EMG signal acquired from the user's trunk is input. While the control EMG signal is not input, the movement of the robotic arm is stopped. Such an EMG-triggered control provides the user controllability. In the following, we describe the components of the system in detail.

The hardware of the simple EMG-SD prosthesis consists of three components: a socket, a robotic arm, and a robotic hand. The socket fixes the robotic arm to the user's body. The material of the socket is a thermoplastic resin. The socket is designed to be mounted on an average adult male torso. The joints of the robotic arm are moved by a direct-drive with servo motors (KRS6003RHV, Kondo Kagaku Co., Ltd., Japan) attached to the base of each shoulder and elbow, and generate flexion and extension movements on the sagittal plane. The length of the upper arm is 225 mm, and the forearm length is 255 mm. The 2-DoF robotic hand is based on an EMG prosthetic hand developed by our research group [33], [34]. The skeleton of the hand is made of a 3D-printed resin. Two servo motors (2BBMG, GWS Co., Ltd., China) are placed at the base of the thumb and four fingers, respectively. Moreover, the robotic hand is covered with an elastomeric glove [35] to give the hand an appearance similar to a healthy human hand and improve the gripping performance owing to friction. The total weight of the hardware is approximately 1.3 kg (Socket, 350 g; Robotic arm, 750 g; Robotic hand and glove, 200 g).

The EMG sensor consists of three components: a dry electrode, an amplifier, and a case. As shown in Figure 1, the EMG sensor is equipped with two exploration electrodes at both ends and a central reference electrode in a silicone case, with a built-in amplifier (AD620, Analog Devices Inc., USA). The two-layered conductive silicone electrodes developed by our research group [36] are used for the electrodes to realize a stable EMG measurement without a gel. The entire sensor is covered with silicone, which is waterproof and robust for measuring the EMG even when the user is sweating.

### Control Method of Proposed System

The control strategy for the proposed system is described in this section. The system employs two primary algorithms: The first is an algorithm that recognises the goal of the reaching movement and plans the robotic arm's movement using visual data obtained by the HoloLens. The

second is an algorithm that estimates the user's motor intention using EMG data from the user's body trunk. The proposed system combines these two algorithms to operate the EMG-SD prosthetic in the manner depicted in As demonstrated in Figs. 2a and 2c, the EMG-SD prosthesis' reaching movement is controlled semi-automatically by merging the aforesaid two algorithms. The proposed control mechanism is briefly described as follows: The proposed system starts out in hand mode, with the user's shoulder adduction and abduction matching to the robotic hand closing and opening. The target is detected with a biting motion, the arm motion is scheduled, and the recommended system switches to the arm operation alamode when the user clicks on operational EMG gazes at the object to be grasped and inputs the user interface (UI).

switching function between the two motion modes is assigned to a biting motion. In the first mode, the user's shoulder reductions and abductions correspond to robotic hand closing and robotic arm lowering, respectively. The shoulder adductions and abductions of the user correspond turbot cram raising and robotic hand opening, respectively, in the second mode. The user receives input on the motion mode status via LEDs mounted to the robotic forearm. The flexion and extension of the user's shoulder movements correspond in a traditional system.

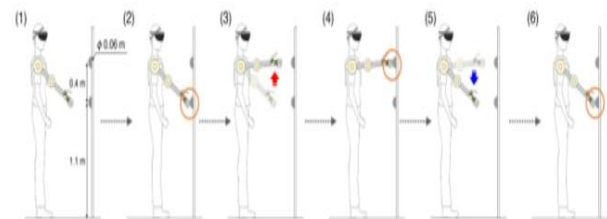

Illustrates how to analyse reaching gestures using an experimental approach. (1) The subject stands in front of a blank wall. (2) The starting point for the measurement is when the robotic hand reaches the lower target. (3) The patient directs the robotic arm to the top right target. (4) The subject collides with the top target. (5) The robotic arm is then returned to the lower target by the individual. (6) The subject finally makes touch with the lower goal. To the flexion and extension movements of the robotic hand and arm, respectively. A switching function between the hand opening and closing processes is required to avoid the seized object from being dropped. Visual feedback controlat the use was issued to control the switching and perception of the motion mode, as well as the execution of the movements, in contrast to the suggested method.

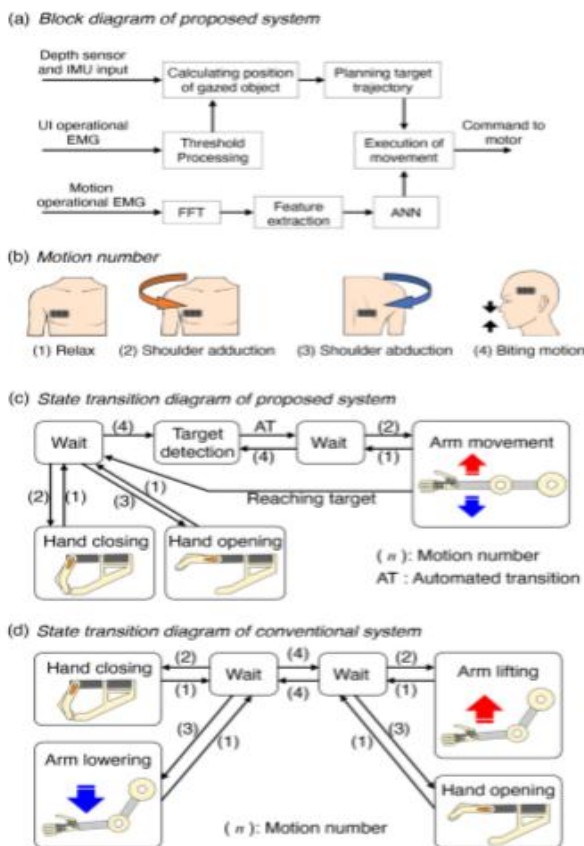

### Control Method of Conventional System

Demonstrates the traditional control mechanism proposed in our prior research [6]. The proposed method used the same position for the EMG sensor and the same EMG information processing method using the ANN. The

### Data Analysis

During the experiment analysing reach-to-grasp movements, we kept track of how long it took to complete the task and how many times it was completed successfully. The mean values of the evaluation index undereach speed condition were calculated for each subject. The variations in both mean indices between the usual and quickest circumstances were also calculated. During both evaluation experiments, the number of overshoots and undershoots to the goal were also recorded. Overshoot and undershoot were defined as when the robotic hand passed the target and the EMG-SD prosthesis or trunk of the user performed a corrective or compensatory movement, and when the robotic hand did

not reach the target and the EMG-SD prosthesis or trunk performed a corrective or compensatory movement, resp

### Statistical Analysis

The effect of the system (proposed or conventional) and the speed conditions on the time taken to complete the task in the experiment evaluating reaching movements, the average sum of the number of overshoots and undershoots in both evaluation experiments, and the number of successes in the experiment evaluating reach-to-grasp movements was investigated using a two-way repeated-measures analysis of variance (ANOVA).

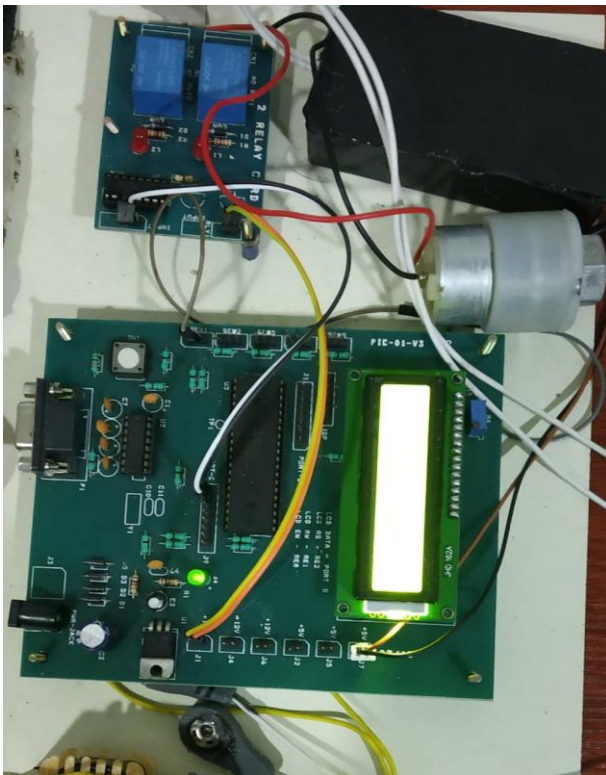

### III. RESULTS

#### Evaluation of Reaching Movements

Shows the findings of an experiment assessing reaching movements In all systems, the time it took to accomplish the task decreased as the robotic shoulder speed rose . Notably, the proposed solution reduced the amount of time it took to complete the task (average 32 percent decrease from normal to fastest conditions). All of the subjects needed less time with the suggested system compared with the existing approach at the quickest condition. When using the proposed system, the time it took to complete

the task from normal to quickest circumstances was about 1.5 seconds faster than when using a standard system . With a rise in the speed of the robotic shoulder, the average sum of the number of overshoots rose in the conventional system, whereas the proposed system changed slightly.

The difference between the usual and quickest circumstances remained basically unaltered in the proposed system, but the traditional system rose by an average of about 0.6 in three of the five trials, indicating that the number of over and undershoots increased (Fig. 5d). These findings show that the proposed system is capable of performing reaching actions with greater precision and speed than the existing metho.

### CONCLUSION

Using an MR device, a semi-automated control system for reaching movements was established in this work to lessen the operational failure of an EMG-SD prosthesis. Based on two evaluation studies, the suggested system was compared to a traditional system, in which all movements were controlled by the user via visual input. The testing results demonstrated that the suggested system can perform reaching actions faster and more correctly than the prior system, as well as apply reach-to-grasp movements more times and with greater accuracy. These findings were especially significant for quick movements, implying that the suggested system can allow users to accomplish tasks using feed forward control rather than visual feedback control, reducing operational failure and enhancing performance. The study's originality is that the suggested system, by coupling The MRdevice with EMG-basedcontrol, might semiautomate the control of the EMG-SD prosthesis. The distinction between this study and earlier studies is that EMG-based control retains voluntary control ability. We conclude that the suggested system can achieve high-performance tasks while lowering the EMG-SD prosthetic user's operational failure.

### REFERENCES

- A. J. Metzger, A. W. Dromerick, R. J. Holley, and P. S. Lum, "Characterization of compensatory trunk movements during prosthetic upper limb reaching task," *Arc. Phys. Med. Rehab.*, vol. 93, no. 11, pp. 2029–2034, 2012.
- D. S. V. Bandara, R. A. R. C. Gopura, K. T. M. U. Hemapala, and K. Kiguchi, "Upper extremity prosthetics: Current status, challenges and future directions," in *Proc. Int. Symp. Artificial Life and Robotics*, 2012, pp. 875–880.

S. Adee, "Dean Kamen's 'Luke Arm' prosthesis ready for clinical trials," IEEE Spectr., vol. 2, no. 34, 2008.

S. Adee, "A 'Manhattan Project' for the next generation of bionic arms," IEEE Spectr., Mar. 2008.

T. A. Kuiken et al., "Targeted muscle reinnervation for real-time myoelectric control of multifunction artificial arms," JAMA, vol. 301, no. 6, pp. 619–628, 2009.

J. M. Souza et al., "Targeted muscle reinnervation: A novel approach to post amputation neuroma pain," Clin. Orthop. Relat. Res., vol. 472, no. 10, pp. 2984–2990, 2014.

T. A. Kuiken, A. K. Barlow, L. J. Hargrove, and G. A. Dumanian, "Targeted muscle reinnervation for the upper and lower extremity," Tech. Orthop., vol. 32, no. 2, pp. 109–116, 2017.