

DESIGN SIMULATION AND FABRICATION OF NACA2412 WIND TURBINE BLADE USING 3D PRINTING

SAKSHI TIWARI¹, Dr. ABHISHEK PRATAP SINGH²

¹Research Scholar, Department of Mechanical Engineering, Shri Ram Murti Smarak College Of Engineering & Technology Bareilly, AKTU Lucknow, INDIA

²Associate Professor, Department of Mechanical Engineering, Shri Ram Murti Smarak College Of Engineering & Technology Bareilly, AKTU Lucknow, INDIA

Abstract - The expansion in worldwide interest for energy and ecological worries has made a shift to sustainable power sources. Wind turbines edges are generally comprised of composite material. An often current version pattern of planning and assembling of cutting edge are through planning programming and Additive Manufacturing Technique. Cutting edge plan programming projects like SOLIDWORKS have offered the chances to upgrade the plan capacities and improvement of more productive sharp edges that can likewise lessen cost and time significantly. Improvement of underlying properties and streamlined execution utilizing NACA series airfoils is the essential goal. In this venture, NACA2412 airfoil has been utilized to plan the breeze turbine edge profile. The cutting edge examples of various t/c proportion are made utilizing PLA by 3D printing innovation. The simulation of the rotor profile have been done, that is Wind Blade Analysis for Wind Power. The possibility of utilizing 3D printed sharp edges in rooftop top power age units is by all accounts reality in not far enough away future.

Key Words: —Computational Modelling, PLA plastic, Blade design, 3D printing.

1. INTRODUCTION

Biodegradable power is the term used to cover those energy streams that happen normally and over and again in the climate and can be tackled for human advantage human advantage. The hour of modest refineries is finished. Humankind can make due without globalization, monetary emergencies and trips to the moon or Mars however not without satisfactory and reasonable energy accessibility. Biodegradable power offers our planet an opportunity to decrease fossil fuel byproducts, clean the air, and put our progress on a more reasonable balance. Inexhaustible a biofuel are a fundamental piece of a general procedure of reasonable twist of fate. Sustainable power sources will give a more broadened, adjusted, and stable pool of fuel sources. Sustainable power sources get their energy from existing progressions of energy from continuous normal cycles, like daylight, wind, streaming water, natural cycles, and geothermal hotness streams. The most encouraging interventional energies Factors embed breeze power, sun

based power, and hydroelectric power. The requirement for power age from sustainable power sources was again growing drastically course of the years with quicker pace of exhaustion in petroleum derivative and rough oils. Sunlight based energy, wind energy & geothermal capacity has been the region under ebb and flow center in research. Latest thing is overwhelmed by wind energy therefore there is an expansion in the quantity of turbines establishment and in addition the rising distance across of turbine rotors with the comparing energy yield per turbine. The presentation of the model turbines created utilizing the AM approach itself was recognizably better compared to that of models delivered manually, the past technique. Presenting the AM technique has likewise given an additional an instructive aspect to this plan construct test project. Using combined FDM & AM innovation, it is feasible to procure such turbine cutting edges by added substance producing, which has given a chance to extraordinarily work on the exactness and finish of the model airfoils that can be delivered, in addition guaranteeing mathematical repeatability of sharp edges on a similar center. It additionally permits to built curvilinear geometries on the underside of their sharp edges, which was remarkably difficult while delivering the cutting edges by hand strategies. This work gives prologue to testing and estimation strategies, as well concerning the benefits and restrictions of the specific AM innovation utilized.

2. LITERATURE REVIEW

Martin Widden, et. al [1], worked on plan, improvement and testing of a scale-model breeze turbine. Creators utilized FDM added AM innovation to deliver turbine sharp edges. AM procedure gave opportunity to plan sharp edges as per their ideal boundaries which was hard to accomplish by hand technique. The work uncovered testing and estimation strategies, benefits and limits of AM innovation. The model was tried at various force sizes and differing of velocities. Dimensionless exhibitions bends of force coefficient against sharp edge tip-speed proportion were plotted. The exhibition of a regular rotor with comparative math could be anticipated with the above bends.

Mun˜oz, et.al [2], explored and showed inventive plans for offshore wind turbines. According to the underlying

perspective, the root is the locale responsible for communicating every a single of heaps of the rotor to the center. Thusly it is vital to remember airfoils with satisfactory underlying properties for this locale. At the root, airfoils utilized were of high-thickness and obtuse following edge to work on the primary attributes of the edge. The aerofoils geometries that has been used as a core Göttingen (GOE), Wortmann (FX), Delft University (DU) and " NREL-SANDIA (FB) aerofoils. Among all, hence Delft University & the Wortmann aerofoils have been opted because of their wellness to the goals & thus specialized determination. DU aerofoils are moderately thick however They maintain a certain following edge hole underneath two % & FX group shows very enormous following edge. From DU pattern of aerofoils DU 95-W-180 & from the FX pattern FX84-W-175 has been picked for looking at.

Richard E. Stamper & Don L. Dekker [3], examined the utilization of fast replication. The FDM interaction utilizes a layer-wise structure cycle to make the part. The FDM fast replication process was utilized for plan approach idea of parametric plan. An airfoil with a Clark Y cross segment was developed from the ABS. A wing from ABS (Acrylonitrile Butadiene Styrene) material to contrast it and an aluminum one of a similar cross-segment. The unpleasant wing didn't compare to the aluminum wing yet after the ABS wing was smoothed, the lift & drag bends moved toward the bends acquired from the aluminum wing. Further tractable and twist test were carried out on another displayed examples.

Peter J. Schubel and Richard J. Crossley [4], looked into wind turbine edge plan, hypothetical most extreme productivity, impetus, viable proficiency and edge loads. A total image of breeze turbine cutting edge plan and the advanced flat hub rotors was illustrated. The streamlined plan standards cutting edge arrangement shape, aerofoil determination and ideal approach were remembered for the audit.

The concentrate likewise portrayed streamlined, gravitational, radiating, gyroscopic and functional circumstances. Both HAWT & VAWT were tried for above given boundaries. It was reasoned that HAWT overwhelmed plan setup and assembling in huge scope. Concentrate on likewise contrasted execution of slim airfoils and thicker airfoils.

N.Manikandan, B.Stalin,[5], coordinated with something like the goal to build dependability of breeze turbine cutting edges across aerofoil anatomy & to reduce the commotion intensity of this windmill throughout its activity. Expert/E, Hypermesh programming was utilized to plan cutting edges. NACA 63-215 aerofoil geometry must have been proposed for its investigation. The windmill rotor was demonstrated and a few segments were made from root to way to improve the productivity. The effectiveness was to be expanded and diminish the clamor constructed from the rotor in working

condition by presenting winglet at the tip of the cutting edge. The regular rotor & altered edges with winglet were looked at for results. The streamlined exhibition was made utilizing computational strategies and the estimation had been anticipated utilizing perfect and dirtied surface. Conventional model was produced for numerous shapes & sizes with related boundaries and was utilized in the pre-plan phase of winglets, where investing greater vitality as in strategy cycle was limited. All the winglets created were planned by the plan measures given by the particular examination papers thus There's none requirement for planning a particular sort vanes through the core., Once this concept had first been utilized.

F.W Perkins & D.E Cromack[6], chipped away at edge pressure examination, plan, streamlined, normal recurrence and cost. The principle issues experienced were streamlined execution, underlying honesty and cost. The issues of the streamlined and underlying honesty were concentrated by NASTRAN programming. The attributes were figured utilizing programs, the general expense as for concept was decreased as redundant codes were utilized. The Rayleigh Ritz strategy was utilized for the arrangement of the normal frequencies. The object of the review was the advancement of PC programs helpful to the breeze turbine planner. Codes were created which permitted a premise to bowing pressure and normal frequencies of WT cutting edges. Great understanding between the anticipated and noticed flexural diversions was displayed alongside normal frequencies. The solid proof for the utilization of Rayleigh's strategy to the issue of free pillar vibration, permitting coupling between redirections in two headings, was legitimate.

Kyoungboo Yang[7], For feasible production, edge modelling comprises linearizing an edge cord & torque spread. Aerofoil discretization modifies a modules, which has an impact on the windmill rotor's aerodynamic efficiency & dynamic performance. As a result, it's critical to comprehend the impacts of the discretization configurations. The impacts of such factors upon that dynamic behavior of a rotor blades were studied in this research. After implementing the discretization value limits drawn from the study to the geometrical parameters, blade geometry with improved aerodynamic efficiency at all wind speeds below the rated wind speed was derived. While using discretization value design ranges and multiple TSRs, a blade geometry that improved the power coefficient in any case Wind velocity beneath the specified Wind velocity compared to the NREL an universal WT was derived. Therefore, It should be essential to consider multiple TSRs during blade design to amaze the optimal aerodynamic performance at various wind speeds. In the future, based on consequences of this study, further research on aerofoil enhancement considering blade structural stability for more practical blade design can be held out.

3. DEVELOPMENT AND FABRICATION OF BLADE

This work researches the flexural stress enduring capacity of model PLA wind factory edges made utilizing 3D printing innovation. NACA series has been utilized to upgrade streamlined execution and underlying properties (cross sectional region and second snapshot of region). NACA 2412 aerofoil is utilized for sharp edge plan. Two digits portraying most extreme thickness of the propeller as percentage of the harmony. For instance, the NACA 2412 aerofoil possesses most extreme curve of 2% found 40% (0.4 harmonies) from the main node with a greatest profundity of 12% of the harmony. The current scenario of the NACA aerofoils is portrayed employing a series of numerals as following "NACA". The confines of the mathematical sequence may could be placed in to the circumstances of exactly produce the cross-segment of the aerofoil & compute its properties.

Next to these points, this shape would be used in a variety of streamlined applications like in wind turbine and in airplane wings to get better lift and decreased measure of drag force. states of the airfoil, which are known as NACA airfoils.

3.1. Blade design

From the writing [2] in previous research two airfoil areas were selected.FX-84-W175 at the root segment for primary strength and NACA4412 for residual range of the edge for streamlined execution. But in current research we have used NACA 2412 airfoil. Yet, in this exploration, different-different ideal harmony length, wind dissemination, and area of each part have been taken for the rotor model [7]. The qualities were input into SOLIDWORKS open source programming to construct a 3d images of the edge and saved in .STL design. There is sharp edge examples with slight variety in thickness to harmony proportion.

Table 4. Representation of cord & torque in base - line & rotors. [7].

r/R	Baseline		Optimized	
	Chord (m)	Twist (°)	Chord (m)	Twist (°)
0.05	3.542	13.308	3.542	9.123
0.09	3.854	13.308	3.854	9.123
0.13	4.167	13.308	4.167	9.123
0.19	4.557	13.308	4.557	9.123
0.25	4.652	11.480	4.567	8.393
0.32	4.458	10.162	4.340	7.663
0.38	4.249	9.011	4.114	6.933
0.45	4.007	7.795	3.888	6.203
0.51	3.748	6.544	3.661	5.473
0.58	3.502	5.361	3.435	4.744
0.64	3.256	4.188	3.209	4.014
0.71	3.010	3.125	2.982	3.284
0.77	2.764	2.319	2.756	2.554
0.84	2.518	1.526	2.530	1.825
0.89	2.313	0.863	2.341	1.216
0.93	2.086	0.370	2.190	0.730
0.98	1.419	0.106	1.419	0.106

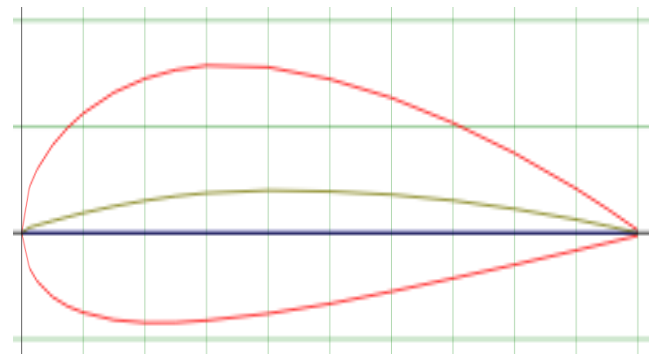
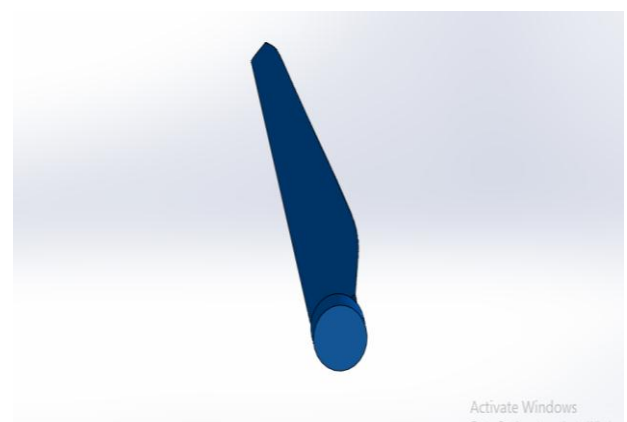
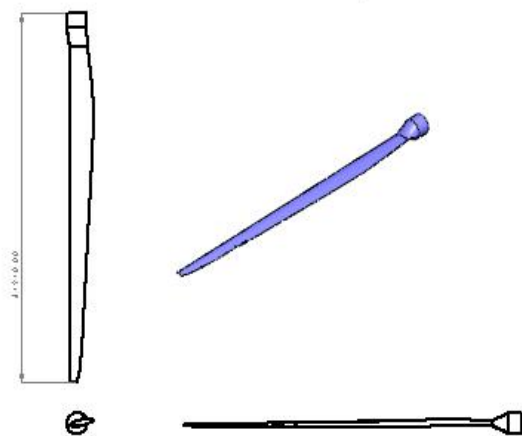

Fig. 1: NACA2412 airfoil section [source: <http://airfoiltools.com/airfoil/details?airfoil=naca2412-il>]



(a)



(b)

Fig.2 (a, b): Wind turbine Blade computational model

3.2. 3D printing is being used to fabricate the turbine

The edges were made utilizing PLA material by 3D printing with the assistance of AM process. The edges were brought into PC in .STL design. The PC isolates the model into number of layers. The device way was created to produce

the cutting edge. Since the base thickness expected for 3D printing was 1mm, the following edge of the edge was modified to dull shape by 0.01% of harmony length. The printing time was 22 hours.



Fig. 3:3D Printed Wind turbine Blade

4. SIMULATION

In the breeze edge examination for wind power the center point is dismissed for straight forwardness since it doesn't add to the electricity generated by a rotor. Just a single edge is considered in the reproduction set-up by utilizing intermittent limit conditions. The recreation yields the speed and tension fields around the rotor and the power produced.

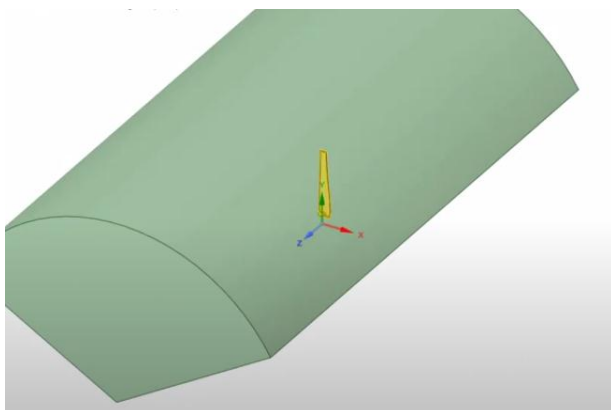
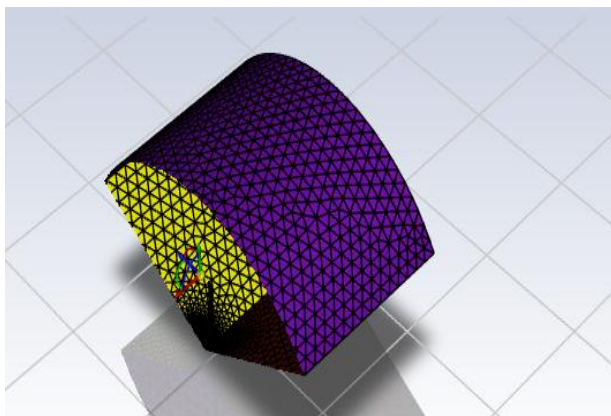
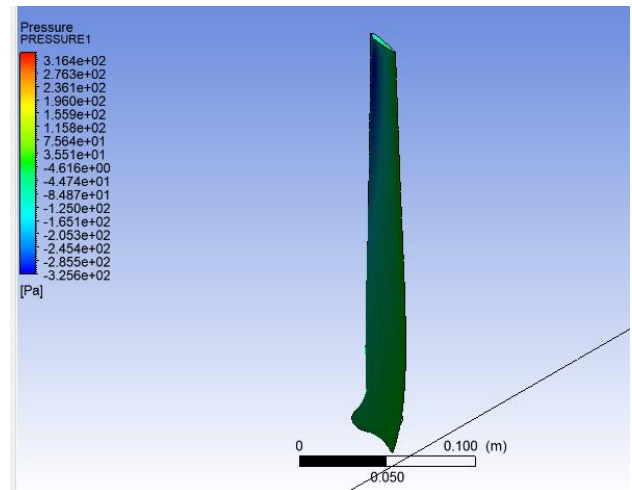

Fig. 4:Simulation of turbine blade

5. RESULTS AND DISCUSSIONS

After doing the simulation we got the torque of the WTB. With this torque we got the intensity of the blade. But it was the capacity of only one blade By multiplying with 3 we got the capacity of the whole turbine.



(a)

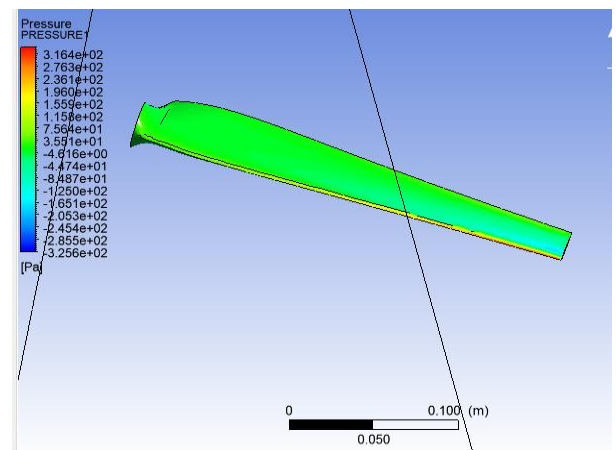

(b)

Fig.5(a, b):Pressure contour 1

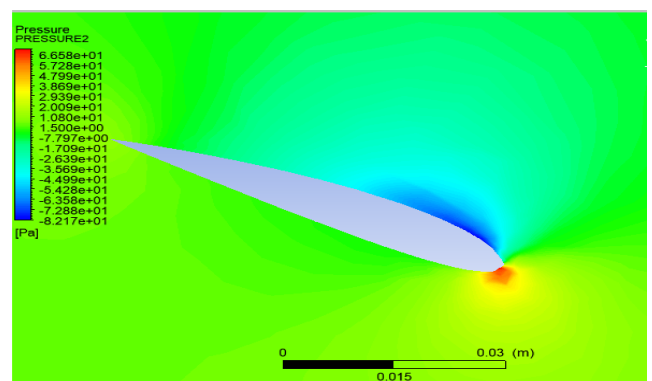

Fig. 6:Pressure contour 2(Torque)

Table 2 : Results

Max Pressure contour1	Max Pressure contour2	Torque	Angular speed	Total Power
3.164e+02	6.658e+01	0.040758 N-m	96 rad/sec	11.7383W

6. CONCLUSIONS

1. The 3DP model edges fabricated involving PLA material showed promising burden conveying ability to be utilized in family rooftop top applications.
2. The job of NACA2412 airfoil area was reliable. The rotors of up to a meter length can endure a lot higher loads and are attainable to be utilized for minimal expense full scale power age units on rooftop tops.
3. Elective materials or breakthroughs in 3DP can be explored for more strength conveying capacity in cutting edges.
4. Additionally progressed airfoil segments grew explicitly tweaked for wind turbine edge root areas can be instilled in plan.

REFERENCES

- [1] Widden, M., Rennie, A., Quayle, S. and Gunn, K., 2011, June. A Basic Design-Build-Test Experience: Model Wind Turbine Using Additive Manufacture. In Proceedings of the 7th International CDIO Conference, Technical University of Denmark, Copenhagen.
- [2] Muñoz, A., Méndez, B. and Munduate, X., 2016, September. Thick airfoil designs for the root of the 10MW INNWIND. EU wind turbine. In Journal of Physics: Conference Series (Vol. 753, No. 2, p. 022046). IOP Publishing.
- [3] Stamper, R.E. and Dekker, D.L., 2000, October. Utilizing rapid prototyping to enhance undergraduate engineering education. In 30th Annual Frontiers in Education Conference. Building on A Century of Progress in Engineering Education. Conference Proceedings (IEEE Cat. No. 00CH37135) (Vol. 2, pp. F3C-1). IEEE.
- [4] Schubel, P.J. and Crossley, R.J., 2012. Wind turbine blade design. *Energies*, 5(9), pp.3425-3449..
- [5] Manikandan, N. and Stalin, B., 2013. Design of NACA63215 airfoil for a wind turbine. *IOSR Journal of Mechanical and Civil Engineering (IOSR-JMCE)*, 10(2), pp.18-26.
- [6] Perkins, F.W. and Cromack, D.E., 1978. Wind turbine blade stress analysis and natural frequencies.
- [7] Yang, K., 2020. Geometry design optimization of a wind turbine blade considering effects on aerodynamic performance by linearization. *Energies*, 13(9), p.2320.