

Analysis of Energy Consumption in MCU for IoT System

Puru Tyagi¹, M. Vishnu Kartik², Dr. Richa Sharma³

^{1,2,3} Dept. of ECE, Amity School of Engineering & Technology, Amity University, Noida, Uttar Pradesh, India

Abstract - Energy efficiency is one of the key requirement to amplify sensor gadget lifetime. Sensor gadgets are commonly controlled by a battery source that has limited lifetime. Most Internet of Thing (IoT) applications require sensor gadgets to work dependably for a lengthy timeframe. To plan an independent sensor gadget, displaying its energy utilization for various tasks is significant. Each errand consumes a power utilization sum for a while. To improve the consumed energy of the sensor gadget and have long correspondence range, Low Power Wide Area Network innovation is thought of. Analysis of energy consumption in MCUs will also going to be performed in sensor devices. The task is that the integration of various energy models that has not been compared earlier, and the energy efficiency when compared to other models. This will help to identify the most efficient wireless solution for IoT applications, which is the main factor in optimizing any device's lifetime.

Key Words: Duty Cycle, SNR, data rate, Bit Error Rate

1. INTRODUCTION

Remote Sensor nodes empower a wide scope of uses, like framework security, climate checking etc [1]. Some of them which are behind gathering data about a given instances. The maximum part sent in an environment where it is harsh. Hence, sensor nodes should work over long timeframes without human involvement.

The expanding variety of IoT use cases has increased the improvement of various new remote conventions planned explicitly for significant distance, low power gadgets, which have been assigned Low Power-Wide Area [2].

Past LPWAN relative reviews have focused on a potential long-term lifetime for gadgets. The main concern in this paper is to show the truth of the energy utilization rates of various remote innovations. Throughput isn't the sole factor in deciding the gadget lifetime of a hub, however it is a component [3]. I straightforwardly look at assessed gadget lifetimes of European organizations of LoRaWAN, Sigfox, NB-IoT, and EC-GSM-IoT hubs for a bunch of day-by-day throughputs.

The main objective is to design an energy efficient and energy utilization of the sensor node utilizing LoRa and LoRaWAN protocol [5]. The model in this is assessed utilizing diverse LoRaWAN modes. Also, we concentrate on the effect of LoRaWAN boundaries like data rate, bit error rate etc [6].

2. SENSORS

2.1 DESIGN OF SENSOR NODE

The node of the sensor can forward information to a point utilizing the radio module. To do its various tasks, this node requires installed power source. We consider an associated sensor to calculate different value. The memory which is internally is coordinated in the micro-controller is sufficient for this utilization which is the outside memory is not considered.

The principle components of this sensor are discussed in briefly below. Each of them is explained clearly in the upcoming paragraphs.

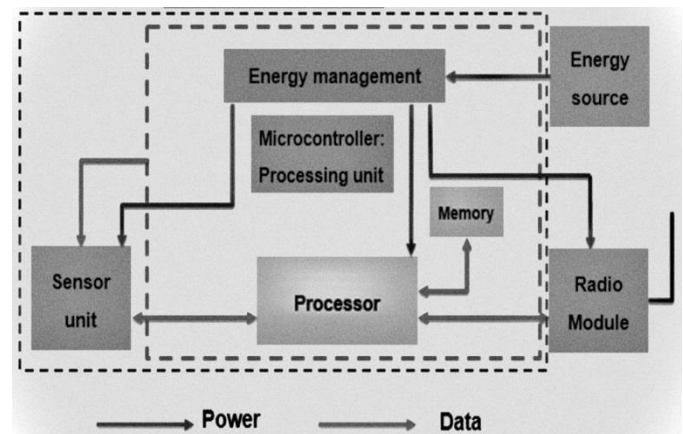

FIGURE-1: Design of a sensor node

1. Sensor Unit

Sensor unit can identify and react to various contributions to the climate. This particular data sources could be heat, force etc. The signal which is inserted is basically signal which is analog that is changed over to the digital signal with an ADC. The ADC is incorporated in this Sensor unit in upcoming review.

2. Processing-Unit

The main processing takes care of the things that is required by the system operation. This provides output signal which is taken from the Unit of the Sensor, computes the information and forwards this information to the next block. Basically, the embedded system which we used in our model is STM32L073 microcontroller. This microcontroller can optimize very low consumption of power.

3. Communicating Unit

When the processing of data is completed, the data is forwarded to this access point. A few of the principles are proposed in the current years for IoT applications. Among these, LoRa and LoRaWAN are acquiring a great deal of interest due to the high sensitivity (approx. -137 dBm). These advancements can arrive for longer distances (up to 20000 m). In our plan model, LoRa/LoRaWAN are utilizing the Semtech's SX1272 handset.

2.1 LoRaWAN TECHNOLOGIES

The LoRa is actually low energy utilization which characterizes the ISM band. The destinations of this innovation are to expand sensor life and lessen the gadget cost. LoRa characterizes the CSS adjustment to keep up with low energy attributes to support expanding correspondence range [7].

The LoRaWAN particular characterizes three classes accessible for various power use systems

1. Class A: For this situation, sensor can start an uplink transmission depend on its own requirements. This class permits bidirectional correspondence, every uplink-transmission is trailed by two short-downlink information. Class A is having least power utilization.
2. Class B: The gateway starts the communication by forwarding downlink messages and get the extra windows at particular time duration. This class has more power utilization when compared to Class A.
3. Class C: These devices have almost open windows, which can possibly be shut while sending. Class C devices characterizes more ability to work than of Class A or Class B however they provide the low signal communication.

Table -2: LoRaWAN Class Characteristics

CLASS	BRIEF DESCRIPTION	POWER CONSUMPTION
CLASS A	Sensor initiate communication, downlink after transmission	Most energy efficient
CLASS B	Slotted communication synchronized with beacon frames	Efficient with controlled downlink
CLASS C	Devices listen continuously, downlink without latency.	high power consumption

2.2 Semtech's SX1272

Long Range, Low Power RF Transceiver 860-1000 MHz with LoRa® Technology

The SX1272/73 handsets highlight the LoRa® long reach modem that gives super long reach spread range correspondence and high obstruction invulnerability while limiting current utilization.

Utilizing Semtech's licensed LoRa regulation strategy SX1272 can accomplish an affectability of over - 137dBm utilizing a minimal expense precious stone and bill of materials. The high affectability joined with the coordinated +20dBm power intensifier yields industry driving connection spending plan making it requiring reach or strength. LoRa likewise gives critical benefits in both hindering and selectivity over ordinary balance methods, tackling the conventional plan compromise between range, impedance resistance and energy utilization.

These gadgets additionally support elite execution (G)FSK modes for frameworks including WMBus, IEEE802.15.4g. The SX1272 convey uncommon stage commotion, selectivity, beneficiary linearity and IIP3 for altogether lower current utilization than contending gadgets.

The SX1272 consolidates the LoRa™ spread range modem which is fit for accomplishing fundamentally longer reach than existing frameworks dependent on FSK or OOK adjustment. With this new regulation plan sensitivities 8 dB better than comparable information rate FSK can be accomplished with a minimal expense, low-resilience precious stone reference. This expansion in connect financial plan gives significantly longer reach and vigor without the requirement for a TCXO or outer intensification [8]. LoRa™. Also gives huge advances in selectivity and obstructing execution, further developing correspondence unwavering quality. For greatest adaptability the client might settle on the spread range tweak transmission capacity (BW), spreading factor (SF) and blunder adjustment rate (CR). One more advantage of the spread tweak is that each spreading factor is symmetrical - consequently numerous sent signs can involve a similar channel without meddling [9]. This likewise allows straightforward conjunction with existing FSK based frameworks. Standard GFSK, FSK, OOK, and GMSK adjustment is additionally furnished to permit similarity with existing frameworks or guidelines, for example, remote MBUS and IEEE 802.15.4g.

The SX1272 offers three data transfer capacity choices of 125 kHz, 250 kHz, and 500 kHz with spreading factors going from 6 to 12.

2.3 Semtech's LR1110

The LR1110 is an ultra-low power platform that integrates a long range LoRa® transceiver, multi-constellation GNSS scanner and passive Wi-Fi AP MAC address scanner targeting geolocation applications.

The LR1110 supports LoRa® and (G)FSK modulations for LPWAN use cases. The device is highly configurable to meet different application requirements utilizing the global LoRaWAN® standard or proprietary protocols.

The LR1110 is designed to comply with the physical layer requirements of the LoRaWAN® specification released by the LoRa Alliance®.

- Low Noise Figure RX front-end for upgraded LoRa/(G) FSK affectability
- Overall ISM recurrence groups support in the reach 150 – 960MHz
- High power PA way +22 dBm
- High proficiency PA way +15 dBm
- Coordinated PA controller supply selector to improve on double power +15/+22dBm with one board execution
- Ready to help overall multi-locale BOM, the circuit adjusts to coordinating with 2144characterize to fulfil administrative cutoff points
- Completely viable with the SX1261/2/8 family and the LoRaWAN standard, 2144characterized by the LoRa Alliance

3. SIGNAL TO NOISE RATIO(SNR)

SNR the ratio of signal power to the noise power, often expressed in decibels.

$$SNR = P_t / (P_l * N_o) \dots\dots\dots(1)$$

Where, P_t is transmitted power in dBm, P_l is pathloss, N_o is noise in dBm.

LoRa handling gain is presented in the RF channel by increasing the information signal with a spreading code or chip grouping. By expanding the chip rate, we increment the recurrence parts of the absolute sign range. As such, energy of all-out signal is presently spread over a more extensive scope of frequencies, permitting the recipient to observe a sign with a lower (that is, more terrible) signal-to-Noise Ratio (SNR).

3.1 PATHLOSS

Path loss, or path attenuation, is the reduction in power density of an as it propagates through space. Path loss is a major component in the analysis and design of the of a telecommunication system [10].

$$L = 10 * n * \log_{10}(d) + C \dots\dots\dots(2)$$

Where, L is the pathloss in decibels, n is the pathloss example, d is the distance from transmitter to the receiver, generally estimated in meters, and C is a constant.

$$P_l = 20 \log_{10} (4\pi/c) + 20 \log_{10} (f) + 20 \log_{10} (d) - G \dots\dots\dots(3)$$

Where, d is defined as the distance from base station antenna, f is the frequency of transmission, c is defined as speed of light.

3.2 Bit Error Rate (BER)

BER is the percentage of bits with errors to the total number of bits that have been transmitted, received, or processed over a given time period. The rate is typically expressed as 10 to the negative power.

$$BER = \frac{1}{2} (1 - (\sqrt{SNR}/(\sqrt{2+SNR})))$$

OR

$$BER = 1/(2 * SNR) \dots\dots\dots(7)$$

Bit Error Rate, BER is utilized as a significant boundary in portraying the presentation of information channels.

$$BER = \text{Errors} / \text{Total Number of bits} \dots\dots\dots(8)$$

Assume the distance between the transmitter and collector is great and the sign to clamor proportion is high, then, at that point, the digit blunder rate will be tiny – potentially immaterial and affecting the general framework However on the off chance that commotion can be recognized, then there is chance that the piece mistake rate should be thought of.

3.2.1 Factors affecting bit error rate(BER)

It very well may be seen from utilizing E_b/N_o , that the piece mistake rate, BER can be impacted by various elements. By controlling the factors that can be controlled it is feasible to upgrade a framework to give the exhibition levels that are required. This is typically attempted in the plan phases of an information transmission framework so the presentation boundaries can be changed at the underlying plan idea stages.

1. **Obstruction:** The impedance levels present in a framework are by and large set by outside factors and can't be changed by the framework plan. Anyway, setting the transfer speed is conceivable. By diminishing the data transmission, the degree of obstruction can be decreased. Anyway, diminishing the transmission capacity restricts the information throughput that can be accomplished.
2. **Increment transmitter power:** It is additionally conceivable to build the power level of the framework so the power per bit is expanded. This must be adjusted against factors including the impedance levels to different clients and the effect of expanding the power yield on the size of the power enhancer and generally speaking power utilization and battery duration, and so forth.
3. **Decrease transfer speed:** Another methodology that can be embraced to diminish the piece mistake rate is to lessen the data transmission. Lower levels of

commotion will be gotten and thusly the sign to clamor proportion will move along. Again, this outcomes in a decrease of the information throughput feasible.

4. **Lower request balance:** Lower request adjustment plans can be utilized, yet this is to the detriment of information throughput.

4. CALCULATIONS AND RESULTS

4.1 SNR VS DISTANCE

4.1.1 LR1110

Table -2: SNR calculations by varying distance, d (5-50m) and P_t (0.1-1 ms), for LR1110

$d \setminus P_t \Rightarrow$	0.1	0.3	0.6	1
5	84.12	84.26	84.59	84.86
10	80.39	80.65	80.75	80.968
20	78.26	78.436	78.69	78.86
30	76.27	76.79	77.27	77.75
40	73.27	74.43	75.28	76.45
50	72.26	73.16	74.12	75.19

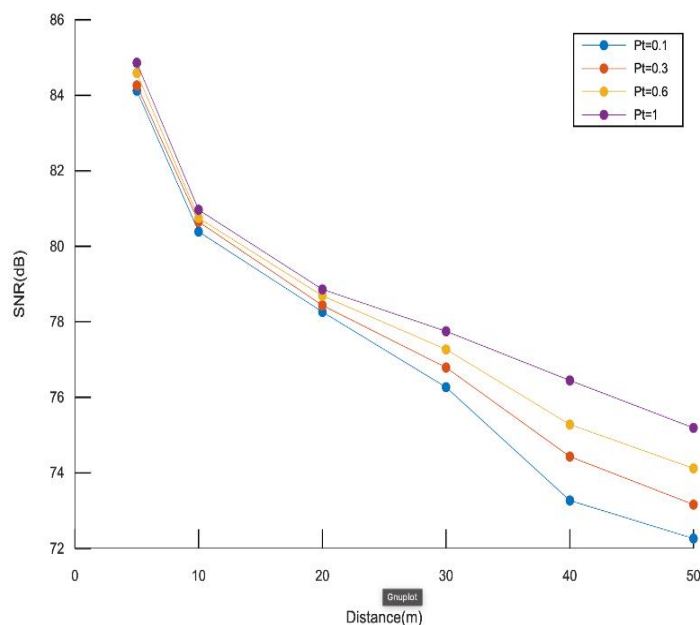

FIGURE-3: SNR vs Distance (LR1110)

It can be observed from the graph in Figure 3, that the SNR varies with the Distance for the sensor device LR1110. As it is observed that the SNR value decreases with the increase in Distance.

The Distance is taken from 0 to 50 m. The least value of SNR is observed at the distance of 50m. The highest value of SNR is observed at the distance of 5m.

4.1.2 SX1272

Table -3: SNR calculations by varying distance, d (5-50m) and P_t (0.1-1 ms), for SX1272

$d \setminus P_t \Rightarrow$	0.1	0.3	0.6	1
5	94.22	94.46	94.69	94.86
10	91.39	91.65	91.75	91.96
20	88.66	88.92	89.21	89.56
30	85.98	86.59	87.17	87.65
40	83.77	84.53	85.28	86.04
50	82.46	83.23	84.19	85.12

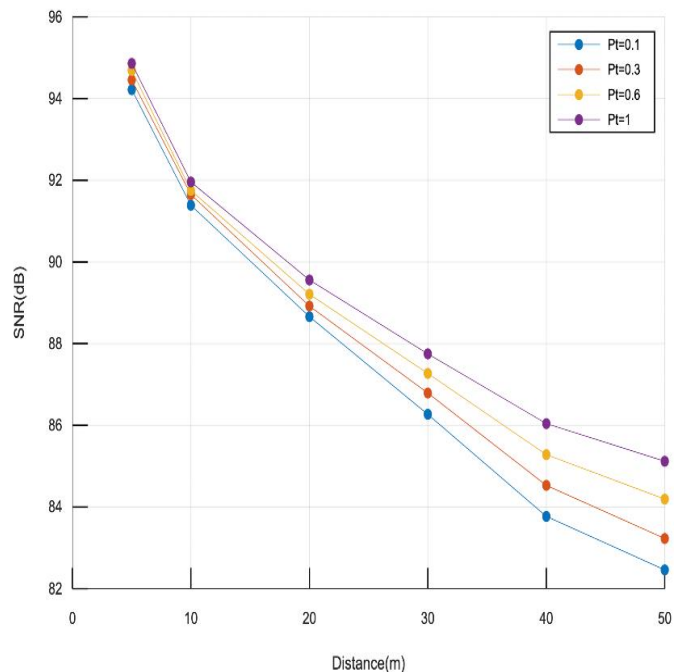

FIGURE-4: SNR vs Distance (SX1272)

It can be observed from the graph in Figure 4, that the SNR varies with the Distance for the sensor device SX1272. As it is observed that the SNR value decreases with the increase in Distance.

The Distance is taken from 0 to 50 m. The least value of SNR is observed at the distance of 50m. The highest value of SNR is observed at the distance of 5m.

4.2 BER VS SNR GRAPHS

4.2.1 LR1110

Table -4: Calculation of BER by varying SNR for P_t(0-1ms)

Pt	0.1		0.3		0.6		1	
	SNR1	BER1	SNR2	BER2	SNR3	BER3	SNR4	BER4
	84.12	1.93 * 10 ⁻⁶	84.26	1.87 * 10 ⁻⁶	84.59	1.73 * 10 ⁻⁶	84.86	1.63 * 10 ⁻⁶
	80.39	4.57 * 10 ⁻⁶	80.65	4.304 * 10 ⁻⁶	80.75	4.206 * 10 ⁻⁶	80.96	4.001 * 10 ⁻⁶
	78.26	7.4 * 10 ⁻⁶	78.43	7.167 * 10 ⁻⁶	78.69	6.76 * 10 ⁻⁶	78.86	6.5 * 10 ⁻⁶
	76.27	11.83 * 10 ⁻⁶	76.79	10.4 * 10 ⁻⁶	77.27	9.37 * 10 ⁻⁶	77.75	8.394 * 10 ⁻⁶
	73.27	23.53 * 10 ⁻⁶	74.43	18.02 * 10 ⁻⁶	75.28	14.8 * 10 ⁻⁶	76.45	11.32 * 10 ⁻⁶
	72.26	29.7 * 10 ⁻⁶	73.16	24.15 * 10 ⁻⁶	74.12	19.36 * 10 ⁻⁶	75.19	15.13 * 10 ⁻⁶

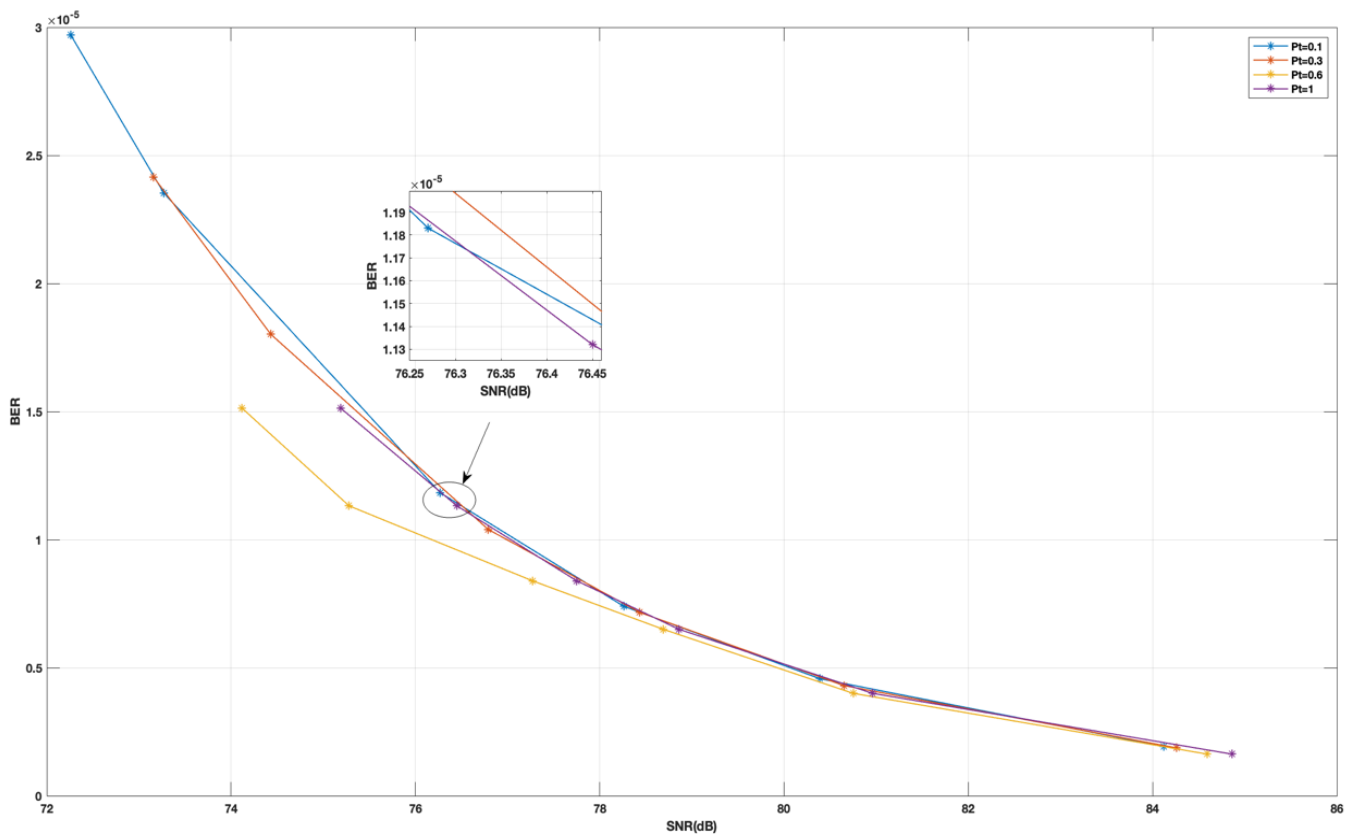

FIGURE-5: BER vs SNR (LR1110)

It can be observed from the graph in Figure 5, that the BER varies with the SNR for the sensor device LR1110. As it is observed that the BER value decreases with the increase in SNR.

The SNR is taken from 72 to 86 dB. The least value of BER is observed at the SNR of 72 dB. The highest value of BER is observed at the SNR of 84.86 dB.

4.2.2 SX1272

Table -5: Calculation of BER by varying SNR for Pt(0-1ms)

Pt	0.1		0.3		0.6		1	
	SNR1	BER1	SNR2	BER2	SNR3	BER3	SNR4	BER4
	94.22	1.89×10^{-7}	94.46	1.79×10^{-8}	94.69	1.69×10^{-7}	94.86	1.63×10^{-7}
	91.39	3.63×10^{-7}	91.65	3.41×10^{-7}	91.75	3.34×10^{-7}	91.96	3.18×10^{-7}
	88.66	6.8×10^{-7}	88.92	6.41×10^{-7}	89.21	5.99×10^{-7}	89.56	5.53×10^{-7}
	85.98	1.26×10^{-6}	86.59	1.09×10^{-6}	87.17	9.59×10^{-7}	87.65	8.58×10^{-7}
	83.77	2.09×10^{-6}	84.53	1.76×10^{-6}	85.28	1.48×10^{-6}	86.04	1.24×10^{-6}
	82.46	2.83×10^{-6}	83.23	2.37×10^{-6}	84.19	1.90×10^{-6}	85.12	1.53×10^{-6}

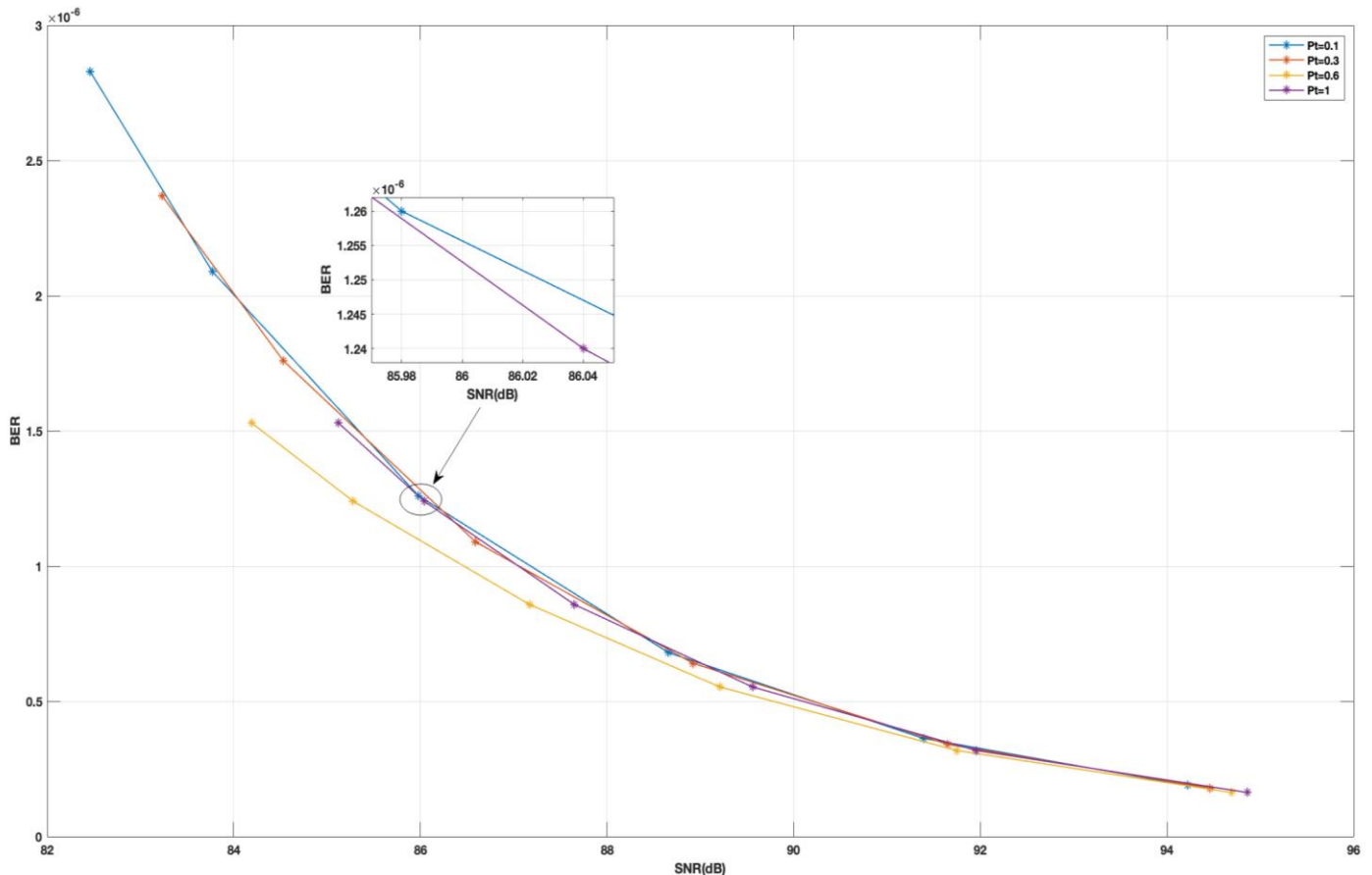

FIGURE-6: BER vs SNR (SX1272)

It can be observed from the graph in Figure 7, that the BER varies with the SNR for the sensor device SX1272. As it is observed that the BER value decreases with the increase in SNR.

The SNR is taken from 82 to 96 dB. The least value of BER is observed at the SNR of 82 dB. The highest value of BER is observed at the SNR of 94.86 dB.

5. CONCLUSION

We displayed through mathematical outcomes that the energy which is consumed through changes with various LoRa boundaries like SNR and BER. A decent decision of these boundaries permits to upgrade the energy consumption by this sensor node which can expand its lifetime.

Energy or power utilization is the most necessities for plan and execution of imparting sensors. This paper, we have optimized the energy consumption using the modulation

technique for the sensor node. The model explains and provides various Long-Range modes and situations for a particular Internet of. To assess the energy/power utilization of this node, we provided diverse situations.

Conference on Distributed Computing in Sensor Systems, Ottawa, ON, Canada, 5-7 June 2019.

REFERENCES

- [1] Wu, H. "An Automatic Energy Consumption Measuring Platform for Embedded Systems". In Proceedings of the 2019 6th International Conference on Information Science and Control Engineering (ICISCE), Shanghai, China, 20-22 December 2019.
- [2] Wu, H. "Two Designs of Automatic Embedded System Energy Consumption Measuring Platforms Using GPIO". *Appl. Sci.* 2020, 10, 4866.
- [3] Thakkar, A.; Chaudhari, K.; Shah, M. "A Comprehensive Survey on Energy-Efficient Power Management Techniques." *Procedia Computer. Sci.* 2020, 167, 1189-1199.
- [4] Adegbija, T.; Rogacs, A.; Patel, C.; Gordon-Ross, A. "Microprocessor Optimizations for the Internet of Things: A Survey." *IEEE Trans. Computer. Aided Des. Integr. Circuits Syst.* 2018, 37, 7-2 14.
- [5] Zaman, N.; Tang Jung, L.; Yasin, M.M. "Enhancing energy efficiency of wireless sensor network through the design of energy efficient routing protocol." *J. Sens.* 2019
- [6] Phui, S.C.; Johan, B.; Chris, H.; Jeroen, F. "Comparison of LoRaWAN Classes and their Power Consumption". In Proceedings of the IEEE Symposium on Communications and Vehicular Technology (SCVT), Leuven, Belgium, 14 November 2017.
- [7] Terrassona, G.; Brianda, R.; Basroub, S.; Arrijuriaa, O. Energy Model for the Design of Ultra-Low Power Nodes for Wireless Sensor Networks. *Procedia Chem.* 2019, 1, 1195-1198.
- [8] Moises, N.O.; Arturo, G.; Mickael, M.; Andrzej, D. Evaluating LoRa Energy Efficiency for Adaptive Networks: From Star to Mesh Topologies. In Proceedings of the IEEE 13th International Conference on Wireless and Mobile Computing, Networking and Communications (WiMob), Rome, Italy, 9-11 October 2020.
- [9] Elodie, M.; Mickael, M.; Roberto, G.; Andrzej, D. Comparison of the Device Lifetime in Wireless Networks for the Internet of Things. *IEEE Access* 2019, 5, 7097-7113.
- [10] Martin, B.; Utz, R. LoRa Transmission Parameter Selection. In Proceedings of the 13th International