

IOT – Based Health Monitoring System

Sufiya V. Rikibdar¹, Priya R. Sawant², Priyanka S. Shingade³, Prof. Vinay Kamble⁴

Student of BE department of Electronics and Telecommunication, Shivaji University

Dr J.J. Magdum College Of Engineering, Jaysingpur, Maharashtra, India.

Abstract - The expanded use of mobile technology and clever devices in the area of fitness has caused tremendous impact on the arena. health experts are an increasing number of taking benefit of the blessings those technologies carry, thus generating a great development in health care in scientific settings. affected person fitness tracking the use of IoT is a era to enable tracking of sufferers out of doors of conventional clinical settings (e.g. in the domestic), which may additionally increase get admission to to care and decrease healthcare shipping prices. this may drastically enhance an character's high-quality of lifestyles. It lets in patients to hold independence, save you headaches, and decrease personal costs. This system helps those desires with the aid of turning in care right to the home. in addition, patients and their circle of relatives contributors feel comfort knowing that they're being monitored and might be supported if a trouble arises. The number one intention became to broaden a reliable patient monitoring gadget the usage of IOT in order that the healthcare professionals can display their sufferers, who're both hospitalized or at domestic the use of an IoT based totally incorporated healthcare system with the view of making sure sufferers are cared for better. A mobile tool primarily based wireless healthcare tracking system was developed which can offer real time on line information about physiological conditions of a affected person especially consists of sensors, the records acquisition unit, microcontroller and programmed with a software program. The affected person's temperature, coronary heart beat rate are monitored, displayed and stored by way of the gadget and despatched to the website. accordingly, IoT primarily based patient tracking gadget efficiently screen patient's fitness fame and store life on time.

the main goal of this venture is to measure temperature, oxygen degree and pulse rate. Pulse price and body temperature are the maximum primary parameters of human fitness. The regular frame temperature of someone depending on various factors, ordinary body temperature range from 97.8o F(36.5o C) to 99o F(37.2o C) for healthful adults. the heart beat rate is a size of the coronary heart price. that is the quantity of times the coronary heart beats per minute.the regular pulse charge degrees from 60 to a hundred beats in step with minute. The normal oxygen saturation stage is between ninety five% and one hundred%. on this device we used microcontroller, oxygen and pulse charge sensor, temperature sensor and wifi module. The measured facts can display on liquid crystal display display in addition to at the website, in order that patient can are searching for scientific interest although the doctors is bodily unavailable. The temperature sensor and oxygen sensor experience and take the records give to the controller which gives records to liquid crystal display show and wifi module and information might be display on liquid crystal display show and website. If a patients oxygen saturation and pulse fee is bizarre, the device have an emergency button.

1.1 Materials and Method

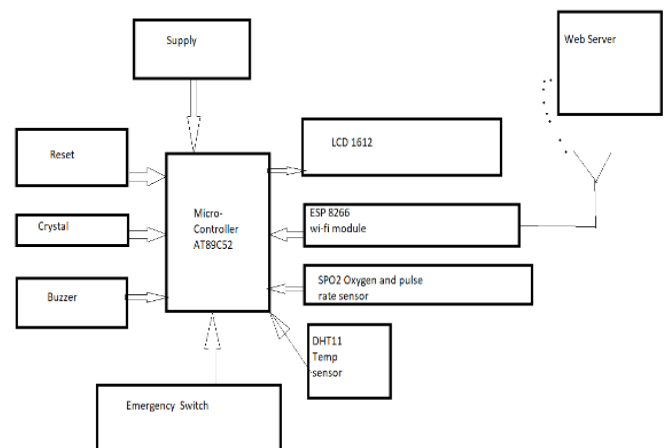

1.INTRODUCTION

Fitness tracking could be very vital ,specially if the early detection of sicknesses can reduce struggling and medical fees. So net of things (IOT) primarily based fitness monitoring device is the answer of it.

far flung health monitoring is a manner to deliver healthcare offerings to patients from remote. it could be used to attain patients in rural areas, the patient is able to keep away from prices of an in-person visit, charges of journeying. every other gain of remote patient tracking is in stopping infectious disorder. patients do not should visit sanatorium or clinic so it could gets rid of the threat of needless contact, mainly for the aged.

On this proposed paintings the crucial parameters which include temperature, oxygen and pulse charge readings which might be monitored with the aid of wifi module. these sensors signals are despatched to wifi module amplifier circuit and conditioning unit(SCU), because the indicators degree are low (benefit), so amplifier circuit is used to

advantage up the signals and transmit the signal to the wifi module. here sufferers body temperature, oxygen and coronary heart price is measured the use of respective sensors and it could be monitored by using the use of web page .it's miles essential for covid-19 sufferers to be regularly informed approximately their health conditions particularly frame temperature, heart fee and oxygen saturation(SPO2).most of the time it's far hard for human beings to get normal fitness checkup appointments, IOT based arrangements can be beneficial for them. The IOT based fitness care gadget is a actual time affected person tracking machine .

while the energy of the machine is switched on ,the sensor starts taking the values. right here the system has the 2 kinds of sensors for measuring oxygen, pulse rate and temperature. The sensors degree all physiological statistics from a human frame and bypass it to controller after which to internet site and displayed facts thru lcd show. From internet site and tool, customers can reveal the temperature level oxygen and pulse charge. If measured oxygen is beneath ninety fivep. cand pulse fee is less than 60 or greater thar ninety, it suggests alert. This measured values can be seen thru internet site and simultaneously thru lcd display. The above diagram is the circuit diagram and is designed the usage of the Proteus design software. This additives are used such as, oxygen sensor and temperature sensor. This system has two parts one is device and other is website. For making the gadget successful, layout implementation performs essential role.

2. Components Used

1) Wifi Module-

We use the ESP8266 for this system, that is a wi-fi community, which could ship information to a server. Wifi module can deliver get admission to to our wifi network. it's miles referred as a standalone wi-fi transceiver. it is specifically used for development of stop factor IOT. it's miles used to permit the internet connections to numerous applications of embedded structures.



2)SPO2 oxygen and pulse rate sensor-

In human frame ,regular spo2 values stages from ninety to 100%.it's miles a coordinated beat oximeter and coronary heart charge sensor which gives particular rvalues.



3)DHT11 temperature and humidity sensor-

DHT11 is a low cost digital sensor for sensing temperature of human frame. This sensor may be effortlessly interfaced with any microcontroller to measure temperature instantaneously. it's miles available as sensor as well as module.It guarantees high reliabilty and amazing long time balance.



4)16x2 LCD Display-

A sixteen x 2 liquid crystal show is a well known alphanumeric liquid crystal display display module, this is it shows each numbers and letters. It has sixteen columns and two rows which might be useful in various device. We used this display to show the measured pulse rate, oxygen and temperature.

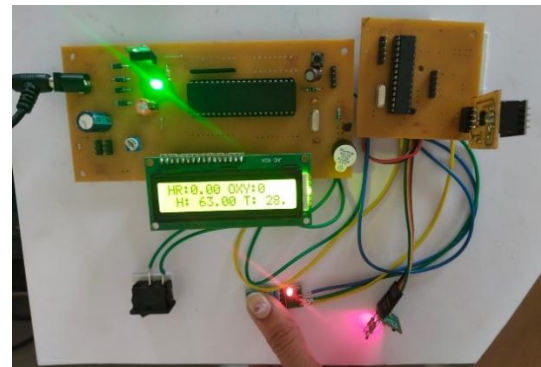

5).AT89C52 Microcontroller-

AT89c52 is an 8-bit microcontroller and belongs to Atmel's 8051 own family. it is a low electricity, excessive overall performance CMOS eight-bit microcomputer with 8k bytes of flash programmable and erasable examine only reminiscence(PEROM).

The system consists of two parts – the hardware and the website. both elements are crucial for the gadget, customers can acquire effects from both. here the microcontroller, liquid crystal display show, pulse sensor, temperature sensor, wifi module were used to put in force the machine. The liquid crystal display display and website show the measured parameters. This device is simple to use. it is able to be without problems moved from one area to another.

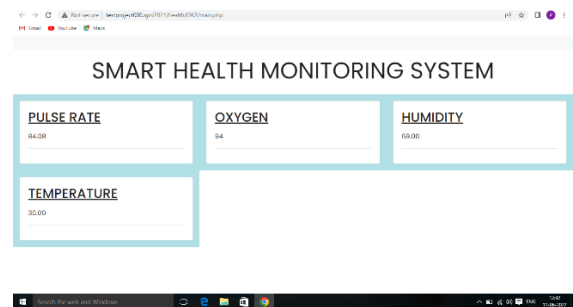

3. RESULTS

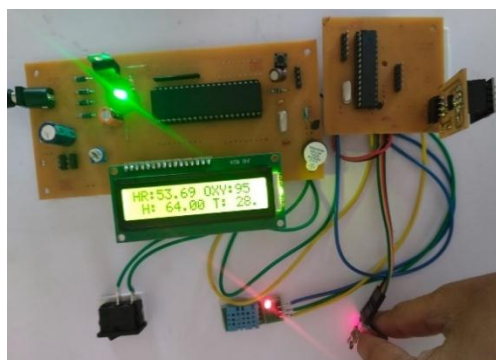

4. CONCLUSION

Various steps including ordinary monitoring of pulse ratw,spo2 degree,and temperature were taken to make certain proper treatment.advanced functions can be introduced in the destiny due to the fact the entire gadget is IOT based. The gadget is price powerful, non-invasive & versatile in nature which makes it simpler to display screen penitent's well being irrespective of wherein they are. moreover it affords real time indicators to concerned character & health workers approximately any situation that calls for activate attention. To finish, the gadget is extremely important in scientific region. In future, more sensors can be delivered to this machine to monitor greater physiological parameters of human frame.

REFERENCES

[1] Punit Gupta1, Deepika Agarwal2, JASmeet Chhabra3,Pulkit Kumar Dhir4,Jaypee college of Infprmtion generation,Himachal Pradesh ,India.
 [2] Prajoona Valsalan1,Tariq Ahmed Barham Baomar2,Ali Huaasain Omar Baabood

- [3] S.Pinto, J.Cabral and T.Gomes Centro algoritmi college of Minho, Portugal
- [4] Sharma S, Tim US, Gadia S, Wong J, "Proliferating Cloud Density through massive statistics atmosphere, Novel XCLOUDX class Emergency of as-a-carrier era" pp-1-20(2015)
- [5] Sandeep Patel, Punit Gupta, Mayank Kumar Goyal, "Low value hardware design of internet server for home automation device ",conference on advances in conversation and control machine
- [6] Alkar, A.Z, Hacettepe Univ; Roach, J. ; Baysal, D., "IP based totally domestic automation device", Coustomer Electronics, IEEE Transactions on ,November 2010, IEEE
- [7] D. Serpanos and M. Wolf, " IOT machine Architectures," in internet-of-matters structures Architectures, Algorithms, Methodologies, Springer global Publising, Switzerland,2019.
- [8] L.D.Xu, W.He, and S.Li, "internet of factors in industries: A survey," IEEE Transactions on commercial Informatics, vol. 10, no.four, pp. 2233-2243, Nov 2014.
- [9] S.M.R Islam, D. Kwak,M.H.Kabir, M. Hossain, and ok.S. Kwak, "The net of things for health care: A comprehensive Survey, IEEE get entry to, vol. three, pp. 678-708, 2015
- [10] A.Zanella, N.Bui, A.Castellani, L. Vangelista, and M. Zorzi, "internet of factors for smart cities," IEEE internet of factors magazine, vol. 1, no. 1, pp. 22-32, Feb 2014.