

# FABRICATION OF AUTOMATIC AGRICULTURAL FERTILIZERS SPRAYING MACHINE

Saurabh S. Kadam<sup>1</sup>, Shubham R. Kulkarni<sup>2</sup>, Shubham S. Salunkhe<sup>3</sup>, Mayur M. Salunkhe<sup>4</sup>

<sup>1,2</sup>Student, Dept. of Instrumentation Engineering, Padm. Vasantraodada Patil Institute of Technology, Sangli, Maharashtra, India

<sup>3,4</sup>Student, Dept. of Mechanical Engineering, Padm. Vasantraodada Patil Institute of Technology, Sangli, Maharashtra, India

\*\*\*

**Abstract** - Agriculture plays a crucial role in the life of an economy. It is the foundation of our economy system. Food and raw materials are provided by agriculture, but it also provides jobs to a significant portion of the population. In agriculture, many machines and equipments are developed and research is carried out. There are many machines and types of equipment that are operated manually to save money. Fertilizers ameliorate the growth of plants. This can be met in two ways, the orthodox one being additives that provide nutrients. The second mode by which some fertilizers act is to ameliorate the effectiveness of the soil by modifying its water retention and aeration. This article, like many on fertilizers, emphasizes the nutritional aspect. Fertilizers typically provide, in varying proportions. We have decided to focus on the multipurpose agricultural machine, in which we will concentrate on the spraying process and try to solve the spraying problem. The efficiency of spraying can be improved by using an engine or prime mover.

**Key Words:** Agriculture, Fertilizers, Food, Spraying, Growth, Machines, Equipments, Farmer.

## 1. INTRODUCTION

Farmers in India prefer spraying methods that are easy to use and require the least amount of work. Because due to miscellaneous labor problems it is very difficult to do all activities related to farming in the stipulated time. Still, the sprayer machines available for the farm in the country are imported. Engine-driven sprayers are fast but the cost is high. Existing manually operated sprayers are inefficient so modification is required. The main reason for the poor acceptance was the low capacity of the machine. A simple manually operated sprayer having an average capacity of one hectare per day would be a better solution. As a safety measure, the robot sprays potentially dangerous chemicals within restricted areas of a farm. So mechanism is required to develop to solve all the problems related to the agricultural sprayer. In this project, we have concentrated on a wheel-operated agricultural sprayer. In which we are trying to develop a machine which will run on remote operated. On farms, Insects are largely responsible for crop destruction. Insecticides or pesticides, a man-made or

natural preparation are used to kill insects or otherwise control their reproduction. These herbicides, pesticides, and fertilizers are applied to agricultural crops with the help of a special device known as a "Sprayer," sprayer provides optimum performance with minimum efforts. The invention of a sprayer, pesticides, and fertilizers, bring revolution to the agriculture or horticulture sector, especially by the invention of sprayers, enabling farmers to obtain the maximum agricultural output. They are used for garden spraying, weed, and pest control, liquid fertilizing, and plant leaf polishing. There are many advantages of using sprayers such as easy to operate, maintain and handle, facilitating the uniform spread of the chemicals at the desired level precision-made nozzle tip for the adjustable stream, and capable of throwing foggy spray, light or heavy spray, depending on the requirement. The agricultural sector is facing problems with capacity issues, shrinking revenues, and labor shortages and increasing consumer demands. The prevalence of traditional agriculture equipment intensifies these issues. In addition, most farmers are desperately seeking different ways to improve the equipment quality while reducing the direct overhead costs (labor) and capital. Thus a significant opportunity rests with understanding the impact of a pesticide sprayer in an agriculture field. A pesticide sprayer has to be portable and with an increased tank capacity as well as should result in cost reduction, labor, and spraying time. In order to reduce these problems, there is a number of sprayers introduced in the market but these devices do not meet the above problems or demands of the farmers. The conventional sprayer has difficulties such as it needs a lot of effort to push the liver up and down in order to create the pressure to spray. Another difficulty of petrol sprayers is to need to purchase fuel which increases the running cost of the sprayer. In order to overcome these difficulties, I have proposed a wheel-driven sprayer, it is a portable device and no need for any fuel to operate, which is easy to move and sprays the pesticide by moving the wheel. The mechanism involved in this sprayer is the reciprocating pump and nozzles which were connected at the front end of the spraying equipment. Indian farmers now employ outdated pasties and spraying techniques, which wastes pesticides and could have negative health effects.

## 2. RESEARCH METHODOLOGY

India is a global agricultural powerhouse. Approximately 70% of our population is dependent on agriculture. Agriculture accounts for one-third of our national income. Our economy is based on agriculture. The development of agriculture has much to do with the economic welfare of our country. Although we are a developing country, we do not use technology to improve our agriculture. So we have to fabricate some machines which can be helpful to farmers so as to increase their profit, production and to save their time. Pesticide spraying is one of the challenges a farmer usually faces. Presently, farmers have to carry pesticides on their shoulders, and sprayers are operated manually. To overcome this problem, we have designed a small four wheel machine which has the capacity to carry up to fifty liters of pesticides. This machine is electronically operated through wireless remote control. The entire machine is powered by a DC battery. The machine consists of the main body frame, battery, DC Motor, Gear Motor, Wiper motor, Wheels, Tank and miniature Centrifugal Pump. It consists of four wheels. The back wheels of the machine are operated by the DC wiper motor. Frame is made up of mild steel. Blowers are attached at a certain height from the frame. The blower height can be adjustable so that it can be used for different crops. The blower is operated by a high speed DC motor that draws the water from the tank and sprays it out. This gear motor rotates the blower through 180 degrees so that the pesticide can be evenly sprayed on both sides of the field. The tank is located on the front of the frame. The transmitter and battery is kept next to the battery. The supply to all the motors and transmitter is provided by a by a 7A DC battery. Initially, the receiver is turned on when the battery supply is turned on. Here, we are using a four-channel RF receiver module (i.e., we can control four motors simultaneously). Relays and 12v DC supplies are used to connect each channel to the motors. Receiving a signal from the transmitter, the receiver sends a command to the relay, which operates the motor, and the motor switches on. In this project, channel A is connected to the wiper motor. When channel A is selected in the transmitter (as shown in the block diagram), the wiper motor is powered ON. It drives the back wheels of the machine and the machine proceeds to move forward. By selecting channel B, the gear motor is turned on and it starts rotating. By simultaneously turning on all three nozzle channels, the machine starts moving and spraying from both sides.

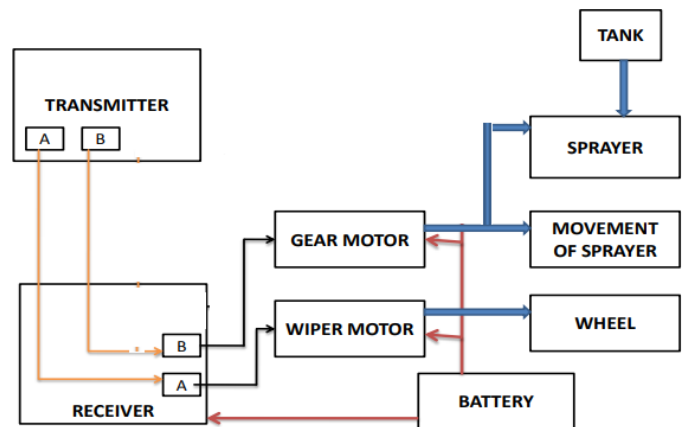

Fig -1: Block diagram of proposed mechanism

## 2.1 SPECIFICATIONS OF PROPOSED MACHINE

Table -1: Specifications

Type	Motorized
Power	DC Power/ Solar Operated
Man Power Req.	1
Dimensions	1230 x 1250 x 835 mm
Weight	30 Kg approx.
Capacity	0.5 acre per hour
Rows capacity	1 rows minimum (2 rows for spraying)
General Information	The machine consists of a chemical tank, Steering mechanism, Arduino circuit

## 3. CALCULATIONS

### 3.1 Capacity of the machine

Total travel of machine in 1 acre

$$\text{Travel distance} = 40 \times 500 = 20000\text{ft} = 6153\text{m}$$

$$\text{Total time required} = 6153 \times 5 = 30765 \text{ sec} = 512\text{min}$$

We have considered Approximately 8 hours 54 min.

So, roughly we can say that the plantation machine capacity is 1 acre/ per day.

Wheel shaft rpm

$$V = \pi DN/60$$

$$V = \pi * 0.6 * N/60$$

$$\text{Since } V = 31.84 \approx 30 \text{ rpm}$$

The distance covered by wheel in 1 revolution  
 $\pi D = \pi * 0.4 = 1.256\text{m}$

### 3.2 Torque required on wheel shaft

Total estimated approximate weight if machine = 15 kg

Total soil drag is considered = 10 kg

Design Factor = 1.2 considered

Total design load = 1.2 \* 25 = 30 kg

P = 300 N

Torque required = P \* Radius of wheel

$$= P * 0.2 = 60Nm$$

We know,

$$P=2\pi NT/60$$

$$P= 2 \times 3.14 \times 40 \times 60 / (60 \times 1000) = 251 \text{ watt}$$

By considering friction & extra jerk in the agricultural field motor / engine / engine power considered

$$P = 0.5 \text{ hp} = 367.5 \text{ watt}$$

### 3.3 Chain Drive

From below table we have determined which chain type is applicable for drive. By considering the agricultural application we are going to design chain drive for 1hp application. From the table as per application and speed we have selected the service factor = 1.3

Design power required = 735 x 1.3= 955 watt

By considering application and extra jerk and safe design prime mover power considered = 955watt

**Table 2:-** Roller Chain Selection

ISO chain number	Pitch p (mm)	Roller diameter d <sub>r</sub> (mm) (max.)	Width b <sub>1</sub> (mm) (min.)	Transverse pitch p <sub>t</sub> (mm)	Breaking load (min) N		
					Simple	Duplex	Triplex
05B	8.00	5.00	3.00	5.64	4 400	7 800	11 100
06B	9.525	6.35	5.72	10.24	8 900	16 900	24 900
08A (ANSI-40)	12.70	7.95	7.85	14.38	13 800	27 600	41 400
08B	12.70	8.51	7.75	13.92	17 800	31 100	44 500
10A (ANSI-50)	15.875	10.16	9.4	18.11	21 800	43 600	65 400
10B	15.875	10.16	9.65	16.59	22 200	44 500	66 700
12A (ANSI-60)	19.05	11.91	12.57	22.78	31 100	62 300	93 400
12B	19.05	12.07	11.68	19.46	28 900	57 800	86 700
16A (ANSI-80)	25.40	15.88	15.75	29.29	55 600	111 200	166 800
16B	25.40	15.88	17.02	31.88	42 300	84 500	126 800
20A (ANSI-100)	31.75	19.05	18.90	35.76	86 700	173 500	260 200
20B	31.75	19.05	19.56	36.45	64 500	129 000	193 500
24A (ANSI-120)	38.10	22.23	25.22	45.44	124 600	249 100	373 700
24B	38.10	25.40	25.40	48.36	97 900	195 700	293 600
28A (ANSI-140)	44.45	25.40	25.22	48.87	169 000	338 100	507 100
28B	44.45	27.94	30.99	59.56	129 000	258 000	387 000
32A (ANSI-160)	50.80	28.58	31.55	58.55	222 400	444 800	667 200
32B	50.80	29.21	30.99	58.55	169 000	338 100	507 100
40A (ANSI-200)	63.50	39.68	37.85	71.55	347 000	693 900	1040 900
40B	63.50	39.37	38.10	72.29	262 400	524 900	787 300
48A	76.20	47.63	47.35	87.83	500 400	1000 800	1501 300
48B	76.20	48.26	45.72	91.21	400 300	800 700	1201 000
64B	101.60	63.50	60.96	119.89	711 700	1423 400	—

From selected dimensions as per application:-

$$C = 450 \text{ mm}; P = 25.4 \text{ mm}; F = t = 24 \text{ teeth's}$$

From above table we have to select factor but there is no speed reduction so K = 1 assumed. L = 1100mm is considered

To calculate tension in the chain drive we have used here Pulley drive formulas:-

P= motor

$$\text{Power } 0.5\text{hp} = 367.5\text{watt.}$$

$$P=V(T_1-T_2)$$

$$V= 1\text{m}/5 \text{ sec}$$

$$V= 0.2\text{m}/\text{sec}$$

$$T_1 - T_2 = 3675 \text{_____} (1)$$

Also,  $T_1/T_2 = e^{\pi\theta}$

$$T_1/T_2 = e^{0.2 * (\pi/180) * 120}$$

$\theta = \text{Angle of wrap} = 120^\circ$

$$e^{0.418} = 1.52$$

$$T_1 / T_2 = 1.52 \text{_____} (2)$$

From Equations (1) & (2)

$$P = V(T_1 - T_2)$$

$$3675 = (T_1 - T_2)$$

$$3675 = 0.52 T_2$$

$$T_2 = 7067.61 \text{ N}$$

$$T_1 = 10742 \text{ N}$$

### 3.4 Design of Drive Shaft

$$\epsilon fy = 0$$

$$T_1 + T_2 - R_A - R_B = 0$$

$$R_A + R_B = 17809$$

Taking the moment about point A

$$(T_1 + T_2) * 100 = 500 R_B$$

$$17809 * 100 = 500 R_B$$

$$R_B = 3561 \text{ N}$$

$$R_A = 14247 \text{ N}$$

Material of shaft considered C40

$$S_{ut} = 580 \text{ N/mm}^2 \text{ \& } S_{yt} = 380 \text{ N/mm}^2$$

Tensile stress ( $\sigma$ ) =  $250F.S.$

$$F.S. = \text{Factor of Safety} = 4$$

$$\sigma = 145 \text{ N/mm}^2$$

Shear Stress ( $\tau$ ):-

As per ASME code

$$\tau = 0.18 * S_{ut} \text{ Or } \tau = 0.3 * S_{yt} \text{ (Whichever is minimum)}$$

$$\tau = 104 \text{ N/mm}^2 \text{ Or } \tau = 99 \text{ N/mm}^2$$

So,  $\tau = 99 \text{ N/mm}^2$  Considered.

Considering key way effect

$$\tau = 0.75 * 99 = 74 \text{ N/mm}^2$$

Considering the following conditions for design of shaft:-  
Design of shaft against bending:-

$$M_A = 14247 \times 500 = 7123569 \text{ N-mm}$$

Design of shaft considering bending:-

$$M_c = \pi/32 * d^3 * \sigma$$

$$d = 24.25 \text{ mm} \quad \underline{\hspace{10em}} \quad 3$$

Design of shaft against torsion.

$$T_e = \pi/16 * d^3 * \tau$$

$$126 * 103 = \pi/16 * d^3 * 74$$

$$d = 20.54 \text{ mm.} \quad \underline{\hspace{10em}} \quad 4$$

Design of shaft considering combined effect As per maximum shear stress theory,

$$M_c = 12 [M + (\sqrt{M^2 + T^2})]$$

$$T_e = \sqrt{M^2 + T^2}$$

From above equation

$$M_c = \pi/32 * d^3 * \sigma$$

So design is safe.

$$T_e = \pi/16 * d^3 * \tau$$

From above equation, hence checking the allowable stress value, from equation 3 & 4 the shaft diameter considered 25mm. Hence Design is safe.

### 3.5 Design of bearing

Total radial load

$$F_r = T_1 + T_2$$

$$F_r = 1914 \text{ N}$$

Total dynamic load

$$P = X * F_r + YF_a$$

$$X = 1$$

$$Y = 1 \text{ (Inner race is rotating)}$$

$$F_a = 0$$

$$Y = 1$$

Hence,

$$P = 1 * 1 * F_r = 1914 \text{ N.}$$

Total life in hours for agricultural application considered

$$L_{10} = 10,000 \text{ Hr}$$

Life in millions of revolution

$$(60 * N * L_h) / 10^6 = (60 * 30 * 10000) / 10^6$$

$$L_{10} = 18 \text{ millions of revolution.}$$

So total dynamic capacity

$$C = P (L_{10})^{1/3} = 1914 * (18)^{1/3} = 5016.09 \text{ N}$$

From SKF table from 20mm shaft diameter Deep Groove Ball Bearing chart, bearing selected is 61904.

### 3.6 Nozzle

We choose single fluid full cone nozzle,  
Discharge of pump = mass flow rate ( $\dot{m}$ )  
5lit/min =  $8.33 * 10^{-5}$  m<sup>3</sup>/sec

$$\dot{m} = \text{density} * \text{area} * \text{velocity}$$

$$\dot{m} = \text{Density} * A * V$$

$$\dot{m} = \text{Density} * \pi/4 * d^2 * V$$

Therefore, From this relation

$$A_1 V_1 = A_2 V_2 \quad V_2 =$$

$$0.0117 \text{ m}^3/\text{sec} \text{ \& } V_1 = 0.00106 \text{ m}^3/\text{sec}$$

### 3.7 Battery

Practically battery charge time should be given as the 40% of battery losses. Battery charge time (theoretically)

$$\text{Wiper motor} = 40 \text{ watt; Pump motor} = 60 \text{ watt}$$

$$\text{Total load} = 40 + 60 = 100 \text{ watts}$$

Current calculation

P-Power of motor; I-current; V-Voltage

a) Wiper motor

$$P=I*V$$

$$36=I*12=3A$$

b) Pump motor

$$P= I*V$$

$$60=I*12=5A$$

So total current is = 3+5 = 8A

Battery back uptime

Total load = 100w

Back uptime= (Battery current \*voltage of battery \*no. of batteries \*efficiency of battery) / Load in watts

Here, we consider 12AH Battery

'N' means no. of batteries

$\eta$  =efficiency is 80%

$$= AH*V*N*\eta /w$$

Battery backup time = 1.15 hrs

## 4. DESIGN CONSIDERATIONS

### 4.1 Rotating Wheels

Generally speaking, a wheel is a circular part that revolves around an axle. Wheels and axles are one of the six simple machines, and the wheel is one of their key components. When wheels are combined with axles, heavy objects may be moved easily, facilitating movement or transportation while supporting a load, or performing labor within a machine. Wheels are also used for other purposes, such as a ship's wheel, steering wheel, potter's wheel and flywheel.

### 4.2 Nozzle

Selecting the correct type and size of spray nozzle is essential for each application. The nozzle determines the amount of spray applied to an area, the uniformity of the application, the coverage of the sprayed surface, and the amount of drift. Crop protection products are applied with only a few types of nozzles, including extended range flat-fans, single fluid full cone nozzles, etc. This is because there are a wide variety of spray applications that can be done with nozzles. Using nozzles, you can disperse liquids over an area, increase liquid surface area, and create impact force on solid surfaces. There are three purposes for using nozzles: to distribute liquids over an area, increase liquid surface area,

and create impact force. Spray nozzles can be described according to a number of spray characteristics in a wide variety of applications. In order to cause atomization, the breakup of the fluid into drops, spray nozzles can be classified according to the amount of energy required. Spray nozzles can have one or more outlets; a multiple outlet nozzle is known as a compound nozzle. Multiple outlets on nozzles are present on spray balls, which have been used in the brewing industry for many years for cleaning casks and kegs. Spray nozzles range from heavy duty industrial uses to light duty spray cans or spray bottles.

### 4.3 Wiper Motor

Usually mounted beneath the cowl (the area outside the windshield's base) or on the firewall, windshield wipers are powered by large electric motors. With the help of the motor, the wiper arms are moved back and forth by the linkage. A separate motor powers the rear window wiper on vehicles with rear window wipers. When the wiper motor doesn't function properly, it can be difficult to see it. The wiper motor is about to fail if it operates slowly or intermittently, runs at one speed, or stops mid-seal. There may also be a problem with other parts of your wiper system if your wipers aren't working. A motor fuse or circuit breaker can be blown if the wiper blades are stuck to the windshield because of ice or snow in the winter. The interior switch that controls the wipers may also fail, as well as wires or the linkage connecting the wiper arms that pushes and pulls them. Lubrication may also be required for moving parts in the linkage that have become stuck due to corrosion and/or gunk.

### 4.4 Microcontroller ESP8266



Fig -2: Microcontroller

WiFi modules like the ESP8266 provide access to your WiFi network for microcontrollers equipped with integrated TCP/IP protocol stacks. A Wi-Fi networking application can be hosted on the ESP8266 or offloaded to another application processor. ESP8266 modules come preprogrammed with AT command set firmware, meaning you can connect them directly to your Arduino device to get WiFi capabilities similar to those in WiFi shields. The ESP8266 module is an extremely cost effective board with a huge, and ever growing, community. The ESP8266 uses a

32bit processor with 16 bit instructions. As well as WIFI communication, it can also be used for connecting to WiFi networks, accessing the Internet, hosting a web server, connecting to Smartphone's etc. Furthermore, the ESP8266 can be programmed like any other microcontroller and especially an Arduino.

#### 4.5 Battery

While it has a high power-to-weight ratio despite having a very small power-to-volume ratio and an extremely low energy-to-volume ratio, it is able to deliver high surge contents despite a very small energy-to-volume ratio. Secondary batteries include lead-acid batteries. There is reversibility in chemical reactions occurring in secondary cells. When current is passed through these batteries (recharging), the reactants that generate an electric current can be regenerated. It is called discharging when current is extracted from a secondary battery (forward reaction).

#### 4.6 Proposed Design

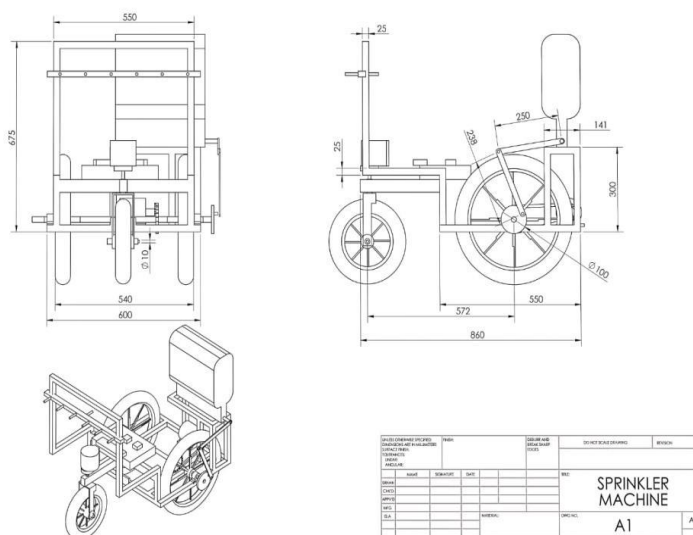

Fig -3: Graphical Design

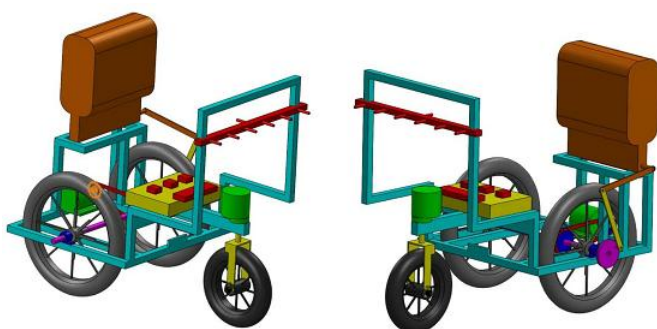

Fig -4: 3D CAD Design

#### 5. CONCLUSION

There is no problem with the machine and it is working as expected. Sprinkling activities in the farm could be streamlined by using this method, which will save time and effort. Most senior citizens and ladies will find the set up very easy to handle. The development of a robot for agricultural purposes is underway. Once robots have been optimized for performance and cost, agricultural spraying operations can be improved. As a result, if this concept is presented appropriately for the Indian market, it will assist in reducing the 15% modality rate observed in Indian formers, which is related to pollution. As for the 15% modality rate related to agricultural spraying operations seen in Indian formers, it will help in reducing it.

#### REFERENCES

- [1] S.R.Kulkarni, Harish Nayak, Mohan Futane, "Fabrication of portable foot operated Agricultural Fertilizer and pesticides spraying pump", "International journal of Engineering Research and technology", ISSN:2278-0181, volume 4, Issue 07(July-2015) Mitul Raval, Aniket Dhandhukia, Supath Mohile, "Development and Automation of Robot with Spraying Mechanism for Agriculture Application", "International journal for Research in Emerging science and technology", E-ISSN:2349-7610, volume 2, ISSUE 8, (Aug-2015 )
- [2] Prof. Swati D.Kale, Swati V. Khandagale, Shweta S. Gaikwad, "Agriculture Drone for Spraying fertilizer and pesticides", "International journal of advance research in computer science and software Engineering", volume 5, Issue 12, (Dec-2015) Designing a Small-Scale Grain Harvester: A Tool for Urban and Peri-urban Growers
- [3] Sandip H. Poratkar, Dhanraj R. Raut, "Development of multi-nozzle pesticide sprayer pump", "International journal of Modern Engineering Research", ISSN: 2249-6645, volume 3, Issue 2, pp-864- 868, (April-2013)
- [4] Sarvesh Kulkarni , Karan Hasurkar , Ramdas Kumbhar, Amol Gonde, Raut A.S "Review of Solar Powered Pesticide Sprayer", "International Journal of Research in Advent Technology", Vol.3, No.4, E-ISSN: 2321-9637 (April 2015)
- [5] [https://www.researchgate.net/publication/314200288\\_Automatic\\_Adjustable\\_Spraying\\_Device\\_for\\_Site-Specific\\_Agricultural\\_Application](https://www.researchgate.net/publication/314200288_Automatic_Adjustable_Spraying_Device_for_Site-Specific_Agricultural_Application)